

# Technical Support Center: Troubleshooting HX630 Experiments

**Author:** BenchChem Technical Support Team. **Date:** April 2026

## Compound of Interest

Compound Name: HX630  
CAS No.: 188844-52-2  
Cat. No.: B127895

[Get Quote](#)

Welcome to the technical support center for **HX630** experiments. This resource is designed for researchers, scientists, and drug development professionals to provide guidance on troubleshooting inconsistent results and to offer standardized protocols for working with the synthetic rexinoid, **HX630**.

## Frequently Asked Questions (FAQs) & Troubleshooting Guide

This section addresses common issues that may lead to inconsistent results in experiments involving **HX630**, a selective retinoid X receptor (RXR) agonist.

Q1: We are observing high variability in our cell-based assays with **HX630**. What are the potential causes?

High variability in cell-based assays can stem from several factors. It is crucial to ensure consistency across all aspects of the experimental setup. Key areas to investigate include:

- **Cell Health and Confluency:** Ensure cells are healthy, within a consistent passage number, and seeded at a uniform density. Overly confluent cells may exhibit altered responses.
- **Pipetting Accuracy:** Inaccurate pipetting can introduce significant variability, especially when working with small volumes in multi-well plates. Calibrated multichannel pipettes and the preparation of master mixes are recommended.
- **Reagent Stability:** Use fresh, properly stored reagents. Avoid repeated freeze-thaw cycles of both **HX630** stock solutions and assay reagents.
- **Plate Effects:** "Edge effects" in multi-well plates can cause variability. To mitigate this, avoid using the outer wells or fill them with a buffer solution. Using white-walled or opaque plates for luminescence assays can reduce background interference from neighboring wells.[\[1\]](#)
- **Transfection Efficiency (for reporter assays):** Inconsistent transfection efficiency is a major source of variability in reporter gene assays. Optimize and standardize the transfection protocol, and consider using an internal control reporter for normalization.[\[1\]](#)

Q2: Our luciferase reporter assay for RXR activation by **HX630** shows a weak or no signal. How can we troubleshoot this?

A weak or absent signal in a luciferase reporter assay can be due to several issues:[\[1\]](#)

- **Inactive Reagents:** Verify the functionality of all assay components, including the luciferase substrate and the **HX630** compound itself.
- **Low Transfection Efficiency:** The cells may not be efficiently taking up the reporter and expression plasmids. Optimize the DNA-to-transfection reagent ratio and ensure the quality of the plasmid DNA.[\[1\]](#)
- **Weak Promoter Activity:** If the reporter construct utilizes a weak promoter, the resulting signal may be low. If possible, consider using a construct with a stronger promoter.
- **Incorrect Cell Line:** Ensure the chosen cell line expresses the necessary components of the RXR signaling pathway and is responsive to RXR agonists.

- **Insufficient Incubation Time:** The incubation time with **HX630** may not be optimal for inducing a measurable response. A time-course experiment may be necessary to determine the peak response time.

Q3: We are seeing a high background signal in our **HX630** luciferase assay. What could be the cause?

High background can obscure the specific signal generated by **HX630** activation of RXR.

Potential causes include:

- **Contamination:** Microbial contamination can lead to high background luminescence. Ensure aseptic techniques and use fresh, sterile reagents.
- **Plate Type:** As mentioned, using clear-bottom, white-walled plates is recommended for luminescence assays to minimize crosstalk between wells.
- **Cell Lysis Inefficiency:** Incomplete cell lysis can result in a high background. Ensure the lysis buffer is effective for the cell line being used.

Q4: The effect of **HX630** on the expression of our target gene is inconsistent across different cell lines. Why might this be?

The activity of **HX630** can be highly cell-type dependent. This is because the transcriptional response to RXR activation is contingent on the cellular context, including the expression levels of its heterodimer partners. For instance, the ability of **HX630** to induce the expression of ABCA1 has been shown to be effective in differentiated THP-1 cells but not in RAW264 or undifferentiated THP-1 cells.<sup>[2]</sup> This difference was linked to the cellular levels of PPAR $\gamma$ , as **HX630** can activate the PPAR $\gamma$ /RXR heterodimer.<sup>[2]</sup> Therefore, it is crucial to select and characterize the appropriate cell model for your specific research question.

## Experimental Protocols

Below are detailed methodologies for key experiments involving **HX630**.

### Protocol 1: General Cell Culture and Maintenance

This protocol provides a basic guideline for maintaining cell lines for use in **HX630** experiments. Specific conditions may vary depending on the cell line.

- Thawing Frozen Cells:
  - Rapidly thaw the vial of frozen cells in a 37°C water bath.
  - Transfer the cell suspension to a sterile centrifuge tube containing pre-warmed complete growth medium.
  - Centrifuge at a low speed (e.g., 100-200 x g) for 5 minutes to pellet the cells and remove the cryoprotectant.
  - Resuspend the cell pellet in fresh, pre-warmed complete growth medium and transfer to a culture flask.
- Cell Passaging:
  - When cells reach the desired confluency (typically 70-90%), remove the culture medium.
  - Wash the cell monolayer with a sterile, calcium- and magnesium-free phosphate-buffered saline (PBS).
  - Add a suitable dissociation reagent (e.g., Trypsin-EDTA) and incubate at 37°C until the cells detach.
  - Neutralize the dissociation reagent with complete growth medium and gently pipette to create a single-cell suspension.
  - Perform a cell count and seed new culture vessels at the desired density.
- Cell Culture Conditions: Maintain cells in a humidified incubator at 37°C with 5% CO<sub>2</sub>.

## Protocol 2: RXR Luciferase Reporter Gene Assay

This protocol outlines a method to quantify the activation of RXR by **HX630** using a luciferase reporter assay.

- Cell Seeding:
  - Seed a suitable cell line (e.g., HEK293T) in a 96-well white, clear-bottom plate at a density that will result in 70-80% confluency on the day of transfection.
- Transfection:
  - Prepare a transfection mix containing an RXR expression plasmid, a luciferase reporter plasmid with an RXR response element (RXRE), and a control plasmid (e.g., expressing Renilla luciferase for normalization).
  - Use a suitable transfection reagent according to the manufacturer's instructions.
  - Add the transfection mix to the cells and incubate for 24 hours.
- Compound Treatment:
  - Prepare serial dilutions of **HX630** in serum-free medium.
  - Replace the transfection medium with the medium containing the different concentrations of **HX630**. Include a vehicle control (e.g., DMSO).
  - Incubate for an additional 18-24 hours.
- Luciferase Assay:
  - Perform a dual-luciferase assay according to the manufacturer's protocol.
  - Measure both firefly and Renilla luciferase activity using a luminometer.
- Data Analysis:
  - Normalize the firefly luciferase signal to the Renilla luciferase signal for each well.
  - Calculate the fold induction of luciferase activity relative to the vehicle control.

## Quantitative Data Summary

The following table provides a template for summarizing quantitative data from a dose-response experiment using **HX630** in a luciferase reporter assay.

<b>HX630 Concentration (nM)</b>	<b>Normalized Luciferase Activity (RLU)</b>	<b>Fold Induction (vs. Vehicle)</b>	<b>Standard Deviation</b>
0 (Vehicle)	10,000	1.0	500
1	25,000	2.5	1,200
10	75,000	7.5	3,500
100	150,000	15.0	7,000
1000	160,000	16.0	8,500

This is example data and will vary based on the experimental conditions.

## Visualizations

### Signaling Pathway of HX630

The following diagram illustrates the mechanism of action of **HX630** as an RXR agonist and its interaction with heterodimer partners LXR and PPAR.

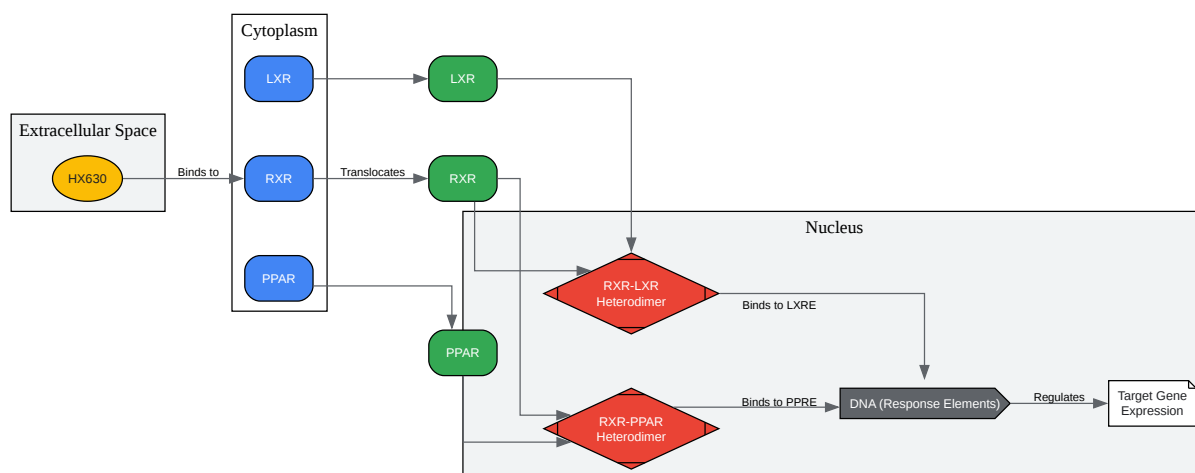

[Click to download full resolution via product page](#)

Caption: **HX630** activates RXR, leading to heterodimerization and gene regulation.

## Experimental Workflow for RXR Luciferase Assay

This diagram outlines the key steps in performing a luciferase reporter assay to measure **HX630** activity.

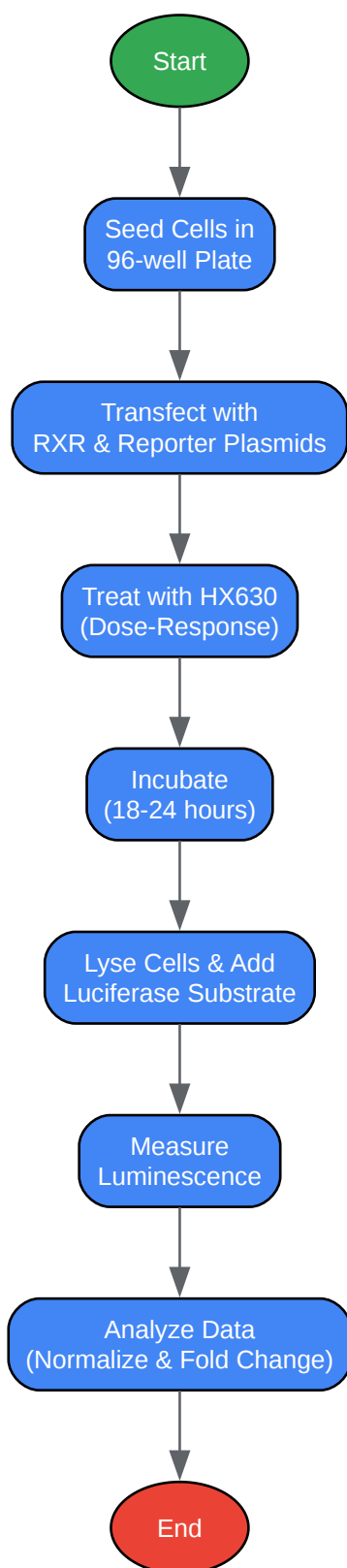

[Click to download full resolution via product page](#)

Caption: Workflow for a luciferase reporter assay to quantify **HX630** activity.

## Troubleshooting Logic for Inconsistent Results

This diagram provides a logical flow for troubleshooting common issues leading to inconsistent experimental outcomes.

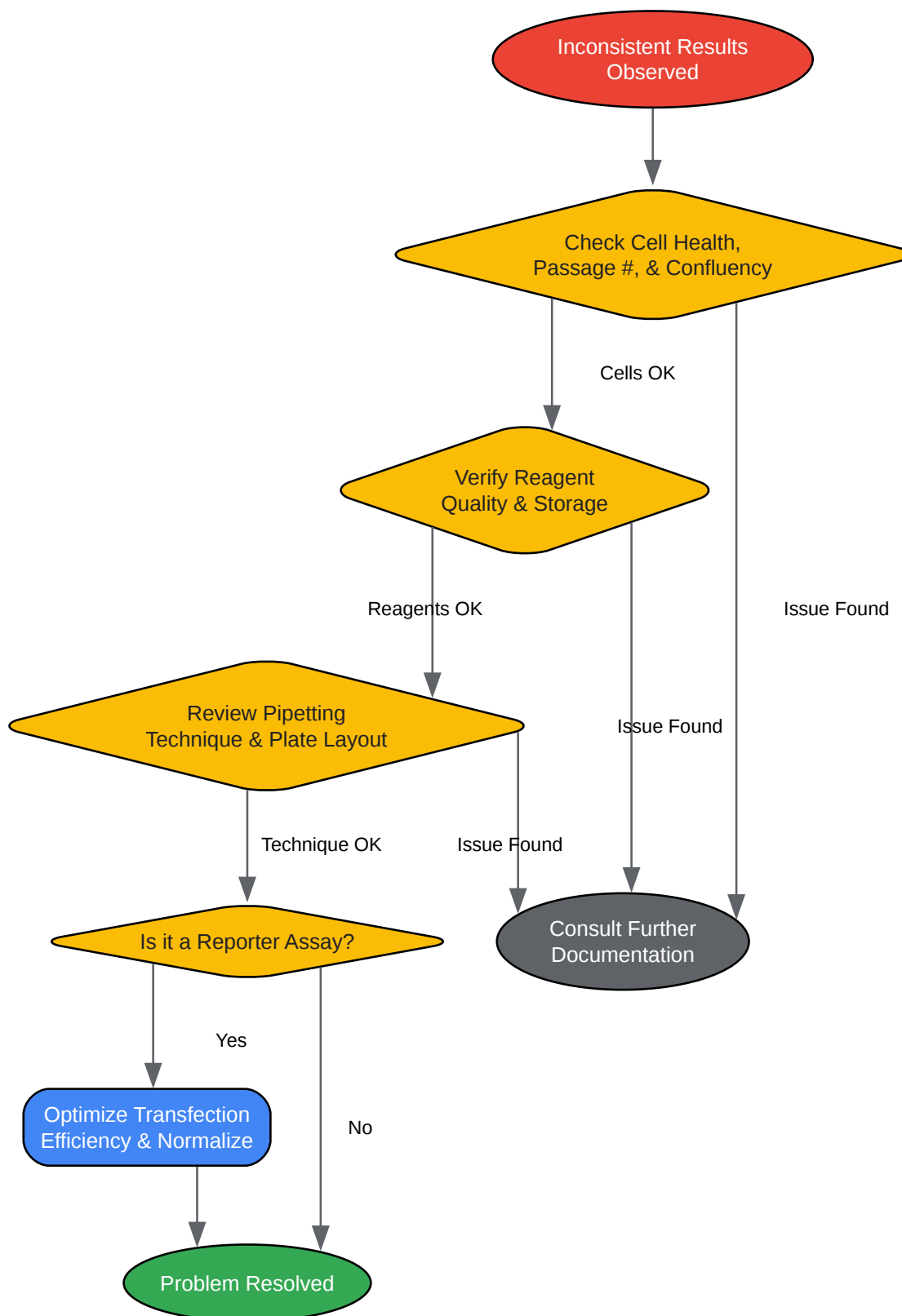

[Click to download full resolution via product page](#)

Caption: A logical approach to troubleshooting inconsistent **HX630** experiment results.

### Need Custom Synthesis?

BenchChem offers custom synthesis for rare earth carbides and specific isotopic labeling.

Email: [info@benchchem.com](mailto:info@benchchem.com) or [Request Quote Online](#).

## References

- [1. bitesizebio.com \[bitesizebio.com\]](https://www.bitesizebio.com)
- [2. The RXR agonists PA024 and HX630 have different abilities to activate LXR/RXR and to induce ABCA1 expression in macrophage cell lines - PubMed \[pubmed.ncbi.nlm.nih.gov\]](#)
- To cite this document: BenchChem. [Technical Support Center: Troubleshooting HX630 Experiments]. BenchChem, [2026]. [Online PDF]. Available at: [\[https://www.benchchem.com/product/b127895/docs#technical-support-center-troubleshooting-hx630-experiments\]](https://www.benchchem.com/product/b127895/docs#technical-support-center-troubleshooting-hx630-experiments)

### Disclaimer & Data Validity:

The information provided in this document is for Research Use Only (RUO) and is strictly not intended for diagnostic or therapeutic procedures. While BenchChem strives to provide accurate protocols, we make no warranties, express or implied, regarding the fitness of this product for every specific experimental setup.

**Technical Support:** The protocols provided are for reference purposes. Unsure if this reagent suits your experiment?

**Need Industrial/Bulk Grade?** [Request Custom Synthesis Quote](#)

## BenchChem

Our mission is to be the trusted global source of essential and advanced chemicals, empowering scientists and researchers to drive progress in science and industry.

### Contact

Address: 3281 E Guasti Rd  
Ontario, CA 91761, United States  
Phone: (601) 213-4426  
Email: [info@benchchem.com](mailto:info@benchchem.com)

Contact our Ph.D. Support Team for a compatibility check