

Technical Support Center: Enhancing the Efficiency of Copper-Catalyzed Sulfonamide Synthesis

Author: BenchChem Technical Support Team. **Date:** May 2026

Compound of Interest

Compound Name:	<i>N,N</i> -dimethylpiperazine-1-sulfonamide
CAS No.:	98961-97-8
Cat. No.:	B1269464

[Get Quote](#)

Welcome to the technical support center for copper-catalyzed sulfonamide synthesis. This resource is designed for researchers, scientists, and professionals in drug development who are looking to optimize their synthetic routes, troubleshoot common issues, and deepen their understanding of this powerful catalytic system. The sulfonamide functional group is a cornerstone in medicinal chemistry, and copper catalysis offers an economical and versatile method for its construction.^{[1][2]} This guide provides field-proven insights and evidence-based protocols to help you navigate the complexities of these reactions and achieve higher efficiency and yields in your experiments.

Frequently Asked Questions (FAQs)

Here, we address some of the most common initial queries encountered when setting up or optimizing copper-catalyzed sulfonamide synthesis.

Q1: What are the main advantages of using copper catalysis for sulfonamide synthesis over traditional methods?

Copper catalysis provides a significant advantage over traditional methods, which often rely on the reaction of an amine with a sulfonyl chloride.^[1] The synthesis of sulfonyl chlorides can require harsh conditions and may not be suitable for complex molecules with sensitive functional groups.^[3] Copper-catalyzed methods, such as the Chan-Lam coupling, allow for the direct formation of the S-N bond from more readily available starting materials like boronic acids, nitroarenes, or sodium sulfinates, often under milder conditions.^{[1][4][5]} This approach offers greater functional group tolerance and access to a broader range of structurally diverse sulfonamides.^{[6][7]} Furthermore, copper is a more abundant and less expensive metal compared to palladium, which is often used in similar cross-coupling reactions.^[8]

Q2: Which copper source is best for my reaction?

The choice of copper source can significantly impact reaction efficiency. Common choices include Cu(I) salts like CuI, CuBr, and CuCl, as well as Cu(II) salts such as Cu(OAc)₂, and CuBr₂.^{[5][9]} The optimal choice is often substrate-dependent. For Chan-Lam type couplings with boronic acids, Cu(OAc)₂ is frequently effective.^[10] In contrast, Ullmann-type couplings with aryl halides often benefit from Cu(I) sources.^[11] It is recommended to screen a few different copper sources during initial reaction optimization. In some cases, "ligand-free" systems using simple copper salts in solvents like water can be highly effective and offer a greener alternative.^[10]

Q3: Is a ligand always necessary for efficient coupling?

While some copper-catalyzed sulfonamide syntheses can proceed without a ligand, particularly under aerobic conditions in water, the addition of a suitable ligand often dramatically improves reaction rates, yields, and substrate scope.^{[10][12]} Ligands serve to stabilize the copper catalyst, prevent catalyst deactivation (e.g., through disproportionation or precipitation), and facilitate the key steps of the catalytic cycle, such as oxidative addition and reductive elimination.^{[13][14]} Diamine ligands, such as 1,10-phenanthroline and N,N'-dimethylethylenediamine (DMEDA), are widely used and have been shown to enable milder reaction conditions.^{[12][13]}

Q4: My reaction is sluggish or gives low yields. What are the first things I should check?

Low conversion is a common issue. Here's a prioritized checklist:

- **Reagent Purity:** Ensure the purity of your starting materials, especially the amine and the sulfonylating agent. Impurities can poison the catalyst.
- **Solvent and Atmosphere:** Anhydrous and deoxygenated conditions are often crucial, especially for reactions sensitive to air and moisture. Ensure your solvent is dry and consider degassing it.
- **Base Selection:** The choice and stoichiometry of the base are critical. Common bases include K_2CO_3 , Cs_2CO_3 , and K_3PO_4 . The base's strength and solubility can significantly affect the reaction outcome.^[9]
- **Temperature:** Some copper-catalyzed reactions require elevated temperatures to overcome activation barriers.^[15] If your reaction is slow at a lower temperature, a systematic increase in temperature may be beneficial.

Troubleshooting Guide

This section provides a more in-depth, problem-oriented approach to resolving specific issues you may encounter during your experiments.

Issue 1: Low or No Product Formation

Potential Cause 1: Inactive Catalyst

- **Explanation:** The active catalytic species may not be forming or is being deactivated. This can be due to impurities in the starting materials or reaction medium, or an inappropriate choice of ligand or base.
- **Troubleshooting Steps:**
 - **Screen Ligands:** If no ligand was used, introduce one. If a ligand was used, screen others. Diamines, picolinamides, and oxalic diamides are good starting points.^[8]

- Vary the Base: The base plays a crucial role in the deprotonation of the sulfonamide and can influence the catalyst's activity. Screen inorganic bases like K_2CO_3 , Cs_2CO_3 , and organic bases like DBU.
- Check Copper Source and Pre-catalyst Activation: Ensure the copper salt is of good quality. In some protocols, pre-forming the copper-ligand complex before adding the substrates can be beneficial.

Potential Cause 2: Poor Substrate Reactivity

- Explanation: Sterically hindered or electron-deficient amines and aryl halides can be challenging substrates.[16]
- Troubleshooting Steps:
 - Increase Temperature: For less reactive substrates, higher temperatures are often necessary to drive the reaction to completion.[11]
 - Use a More Reactive Coupling Partner: If using an aryl chloride, switching to the corresponding aryl bromide or iodide can significantly increase reactivity.[9]
 - Alternative Sulfonylating Agents: For unreactive amines, consider more potent sulfonylating agents or alternative catalytic systems.[16]

Issue 2: Formation of Significant Side Products

Potential Cause 1: Homocoupling of Boronic Acids

- Explanation: In Chan-Lam type reactions using aryl boronic acids, the homocoupling of the boronic acid to form a biaryl byproduct can be a significant competing reaction.
- Troubleshooting Steps:
 - Optimize Reaction Conditions: Lowering the reaction temperature or reducing the catalyst loading can sometimes minimize homocoupling.
 - Control Stoichiometry: Using a slight excess of the sulfonamide relative to the boronic acid can favor the desired cross-coupling pathway.

- Atmosphere Control: Running the reaction under an inert atmosphere (e.g., nitrogen or argon) can suppress oxidative homocoupling.

Potential Cause 2: N-Dealkylation/N-Arylation of Secondary Sulfonamides

- Explanation: When using certain secondary N-alkyl sulfonamides, copper-mediated oxidative dealkylation followed by N-arylation can occur, leading to an undesired product.^[17]
- Troubleshooting Steps:
 - Substrate Modification: If possible, choose a different N-substituent on the sulfonamide that is less prone to cleavage.
 - Mechanistic Investigation: Understanding the specific conditions that favor this side reaction can help in its mitigation. This may involve adjusting the oxidant or reaction temperature.

Issue 3: Difficulty in Product Purification

Potential Cause: Residual Copper in the Product

- Explanation: Copper salts and complexes can be difficult to remove completely from the final product, leading to colored impurities and potential issues in downstream applications.
- Troubleshooting Steps:
 - Aqueous Workup with Chelating Agents: Washing the organic extract with an aqueous solution of a chelating agent like aqueous ammonia or a dilute solution of EDTA can help sequester and remove copper ions.
 - Silica Gel Chromatography with Additives: Adding a small amount of a chelating agent (e.g., triethylamine) to the eluent during column chromatography can improve the separation of the product from copper residues.
 - Use of Scavenger Resins: Passing a solution of the crude product through a column packed with a copper scavenger resin can be a highly effective purification method.

Experimental Protocols & Methodologies

Protocol 1: General Procedure for Copper-Catalyzed N-Arylation of Sulfonamides with Arylboronic Acids (Chan-Lam Coupling)

This protocol is a starting point and may require optimization for specific substrates.

- **Reaction Setup:** To an oven-dried reaction vial equipped with a magnetic stir bar, add the sulfonamide (1.0 mmol), arylboronic acid (1.2 mmol), $\text{Cu}(\text{OAc})_2$ (0.1 mmol, 10 mol%), and a suitable base such as K_2CO_3 (2.0 mmol).
- **Solvent Addition:** Add the desired solvent (e.g., toluene, DMF, or water, 5 mL).^[10]
- **Reaction Execution:** If an organic solvent is used, degas the mixture by bubbling with nitrogen or argon for 10-15 minutes. Seal the vial and heat the reaction mixture to the desired temperature (typically 80-110 °C) with vigorous stirring.
- **Monitoring:** Monitor the reaction progress by TLC or LC-MS.
- **Workup:** After completion, cool the reaction to room temperature. Dilute with an appropriate organic solvent (e.g., ethyl acetate) and wash with water and brine. To remove residual copper, an additional wash with aqueous ammonia may be performed.
- **Purification:** Dry the organic layer over anhydrous Na_2SO_4 , filter, and concentrate under reduced pressure. Purify the crude product by flash column chromatography on silica gel.

Data Presentation: Optimizing Reaction Parameters

The following table provides a hypothetical example of an optimization study for the N-arylation of methanesulfonamide with phenylboronic acid, demonstrating how to systematically evaluate different parameters.

Entry	Copper Source (mol%)	Ligand (mol%)	Base (equiv.)	Solvent	Temp (°C)	Yield (%)
1	Cu(OAc) ₂ (10)	None	K ₂ CO ₃ (2)	Toluene	100	45
2	CuI (10)	None	K ₂ CO ₃ (2)	Toluene	100	30
3	Cu(OAc) ₂ (10)	DMEDA (20)	K ₂ CO ₃ (2)	Toluene	100	85
4	Cu(OAc) ₂ (10)	DMEDA (20)	CS ₂ CO ₃ (2)	Toluene	100	92
5	Cu(OAc) ₂ (10)	DMEDA (20)	CS ₂ CO ₃ (2)	DMF	100	88
6	Cu(OAc) ₂ (10)	DMEDA (20)	CS ₂ CO ₃ (2)	Toluene	80	75

DMEDA = N,N'-dimethylethylenediamine

Visualizing Key Concepts

Catalytic Cycle of Chan-Lam N-Arylation

The following diagram illustrates the generally accepted catalytic cycle for the copper-catalyzed N-arylation of a sulfonamide with a boronic acid.

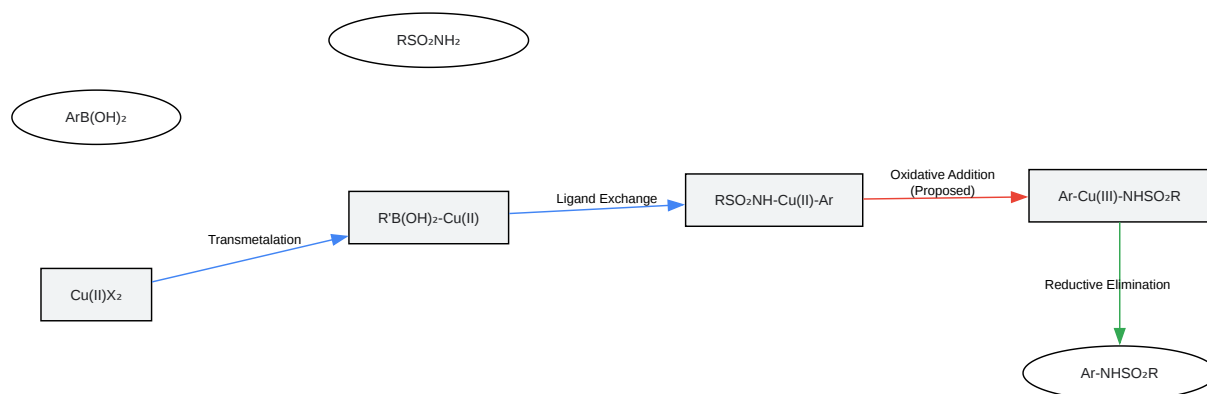

[Click to download full resolution via product page](#)

Caption: Proposed catalytic cycle for Chan-Lam N-arylation.

Troubleshooting Workflow for Low Yield

This decision tree provides a systematic approach to diagnosing and solving low yield issues in your reaction.

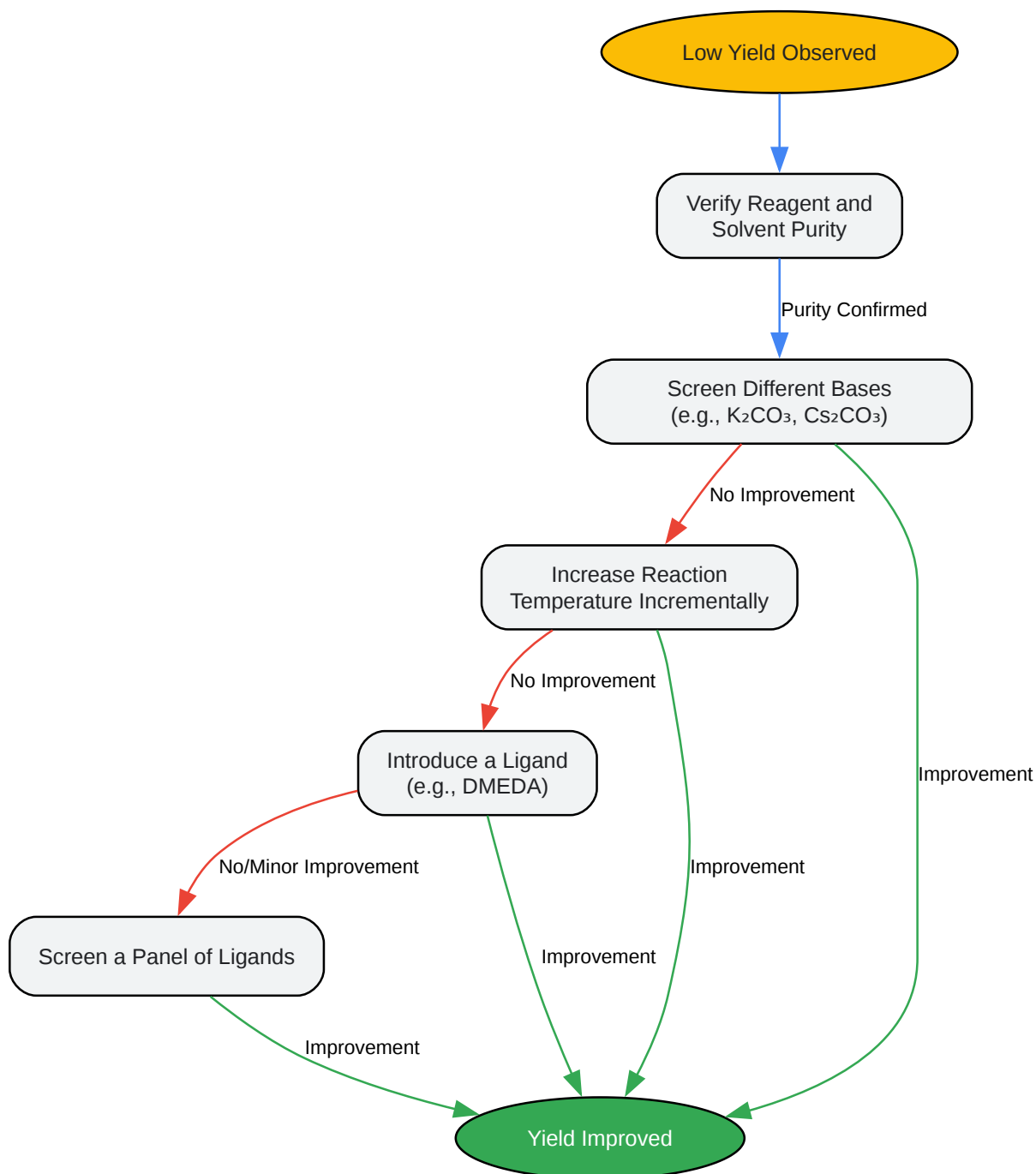

[Click to download full resolution via product page](#)

Caption: A decision tree for troubleshooting low reaction yields.

References

- Willis, M. C., et al. (2017). Direct Copper-Catalyzed Three-Component Synthesis of Sulfonamides. *Angewandte Chemie International Edition*, 56(45), 14033-14037. [[Link](#)]
- Jiang, Y., et al. (2017). Copper-catalyzed synthesis of sulfonamides from nitroarenes via the insertion of sulfur dioxide. *Chemical Communications*, 53(75), 10442-10445. [[Link](#)]
- Pramanik, M. M. D., et al. (2018). Microwave assisted, Cu-catalyzed synthesis of sulfonamides using sodium sulfinates and amines. *Synthetic Communications*, 48(14), 1779-1787. [[Link](#)]
- Kim, H. J., et al. (2023). Direct Synthesis of Sulfonamides via Synergetic Photoredox and Copper Catalysis. *Organic Letters*, 25(34), 6358–6363. [[Link](#)]
- Evano, G., & Thilmany, P. (2014). Diamine Ligands in Copper-Catalyzed Reactions. *Israel Journal of Chemistry*, 54(10), 1547-1562. [[Link](#)]
- Nasrollahzadeh, M., Ehsani, A., & Maham, M. (2014). Copper-Catalyzed N-Arylation of Sulfonamides with Boronic Acids in Water under Ligand-Free and Aerobic Conditions. *Synlett*, 25(04), 505-508. [[Link](#)]
- Wikipedia. (n.d.). Ullmann condensation. [[Link](#)]
- Teo, Y.-C., & Chua, Y. (2012). Copper catalyzed N-arylation of sulfonamides with aryl bromides under ligand-free conditions. *Tetrahedron Letters*, 53(1), 93-96. [[Link](#)]

Need Custom Synthesis?

BenchChem offers custom synthesis for rare earth carbides and specific isotopic labeling.

Email: info@benchchem.com or [Request Quote Online](#).

Sources

- 1. scispace.com [scispace.com]
- 2. [One-Pot Synthesis of Diaryl Sulfonamides via Metal Catalysis - Thieme Chemistry - Georg Thieme Verlag](#) [thieme.de]
- 3. pubs.acs.org [pubs.acs.org]

- [4. Copper-catalyzed synthesis of sulfonamides from nitroarenes via the insertion of sulfur dioxide - Chemical Communications \(RSC Publishing\) \[pubs.rsc.org\]](#)
- [5. tandfonline.com \[tandfonline.com\]](#)
- [6. researchgate.net \[researchgate.net\]](#)
- [7. researchgate.net \[researchgate.net\]](#)
- [8. New ligands enhance copper catalysis-SINOCOMPOUND \[en.sinocompound.com\]](#)
- [9. repository.nie.edu.sg \[repository.nie.edu.sg\]](#)
- [10. Copper-Catalyzed N-Arylation of Sulfonamides with Boronic Acids in Water under Ligand-Free and Aerobic Conditions \[organic-chemistry.org\]](#)
- [11. Ullmann condensation - Wikipedia \[en.wikipedia.org\]](#)
- [12. Diamine Ligands in Copper-Catalyzed Reactions - PMC \[pmc.ncbi.nlm.nih.gov\]](#)
- [13. Diamine Ligands in Copper-Catalyzed Reactions. | Semantic Scholar \[semanticscholar.org\]](#)
- [14. pubs.acs.org \[pubs.acs.org\]](#)
- [15. pdf.benchchem.com \[pdf.benchchem.com\]](#)
- [16. pdf.benchchem.com \[pdf.benchchem.com\]](#)
- [17. \[PDF\] Discovery, Scope, and Limitations of an N -Dealkylation/ N -Arylation of Secondary Sulfonamides under Chan–Lam Conditions | Semantic Scholar \[semanticscholar.org\]](#)
- To cite this document: BenchChem. [Technical Support Center: Enhancing the Efficiency of Copper-Catalyzed Sulfonamide Synthesis]. BenchChem, [2026]. [Online PDF]. Available at: [<https://www.benchchem.com/product/b1269464/docs#technical-support-center-enhancing-the-efficiency-of-copper-catalyzed-sulfonamide-synthesis>]

Disclaimer & Data Validity:

The information provided in this document is for Research Use Only (RUO) and is strictly not intended for diagnostic or therapeutic procedures. While BenchChem strives to provide accurate protocols, we make no warranties, express or implied, regarding the fitness of this product for every specific experimental setup.

Technical Support: The protocols provided are for reference purposes. Unsure if this reagent suits your experiment?

Need Industrial/Bulk Grade? [Request Custom Synthesis Quote](#)

BenchChem

Our mission is to be the trusted global source of essential and advanced chemicals, empowering scientists and researchers to drive progress in science and industry.

Contact

Address: 3281 E Guasti Rd
Ontario, CA 91761, United States
Phone: (601) 213-4426
Email: info@benchchem.com

[Contact our Ph.D. Support Team for a compatibility check](#)