

Application Note: Comprehensive Characterization of 5-(1,3-Benzoxazol-2-yl)-2-methylaniline

Author: BenchChem Technical Support Team. **Date:** May 2026

Compound of Interest

Compound Name:	5-(1,3-Benzoxazol-2-yl)-2-methylaniline
CAS No.:	292644-38-3
Cat. No.:	B1269585

[Get Quote](#)

Introduction & Scope

This application note details the analytical protocols for the structural and photophysical characterization of **5-(1,3-Benzoxazol-2-yl)-2-methylaniline** (CAS: N/A, PubChem CID: 721030).[1] This molecule represents a classic "push-pull" fluorophore architecture, featuring an electron-donating amine/methyl-substituted phenyl ring conjugated to an electron-withdrawing benzoxazole heterocycle.[1]

Such scaffolds are critical intermediates in the synthesis of:

- Fluorescent Probes: For biological imaging (DNA/RNA intercalation).[1]
- Scintillators: For radiation detection.[1]
- Medicinal Chemistry: As pharmacophores with antimicrobial and antitumor potential.[2]

This guide moves beyond basic identification, providing a rigorous workflow to validate identity, purity, and functional performance (fluorescence quantum yield).

Analytical Workflow Overview

The characterization lifecycle is divided into three phases: Identity (Is it the right molecule?), Purity (Is it clean?), and Function (Does it perform?).

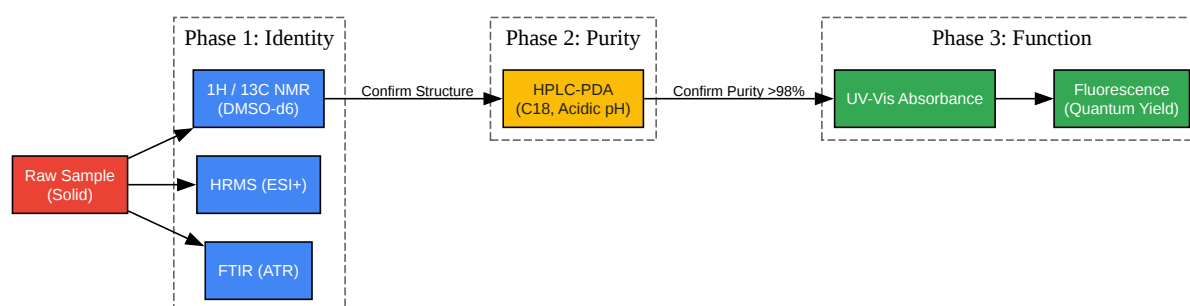

[Click to download full resolution via product page](#)

Figure 1: Integrated analytical workflow ensuring structural confirmation precedes functional testing.

Phase 1: Structural Confirmation (Identity)[1]

Nuclear Magnetic Resonance (NMR)

Rational: The primary amine (-NH₂) and the benzoxazole nitrogen are capable of hydrogen bonding.[1] DMSO-d₆ is the solvent of choice over CDCl₃ to ensure solubility and to slow down proton exchange, allowing the amine protons to appear as a distinct singlet or broad peak rather than disappearing.

Protocol:

- Preparation: Dissolve 10 mg of sample in 0.6 mL DMSO-d₆.

- Acquisition:
 - H NMR: 16 scans, relaxation delay (d1) = 1.0 s.[1]
 - C NMR: 1024 scans, proton decoupled.
- Key Assignments (Expected):

Moiety	Proton Type	Approx.[1][2] [3][4] Shift (ppm)	Multiplicity	Diagnostic Value
Amine	-NH	5.0 - 6.5	Broad Singlet	Confirms free amine; disappears with D O shake.[1]
Methyl	Ar-CH	2.1 - 2.3	Singlet	Diagnostic for the 2-methyl group.[1]
Benzoxazole	Ar-H (Ring)	7.3 - 7.8	Multiplets	Characteristic aromatic pattern of the fused ring. [1]
Linker	Ar-H (Aniline C4/C6)	7.0 - 8.0	Doublet/Singlet	Confirms substitution pattern (1,2,5-trisubstituted).[1]

High-Resolution Mass Spectrometry (HRMS)

Rational: Electrospray Ionization (ESI) in positive mode is ideal due to the basicity of the primary amine and the benzoxazole nitrogen.[1]

Protocol:

- Solvent: Methanol with 0.1% Formic Acid (promotes protonation).[1]
- Mode: ESI+ (Positive Ion Mode).
- Target Ion: [M+H]
- Calculation:
 - Formula: C
H
N
O[1]
 - Exact Mass: 224.0950[1]
 - Expected [M+H]
: 225.1022[1]

Phase 2: Purity Assessment (HPLC-PDA)

Rational: Benzoxazole derivatives are hydrophobic.[1] A Reverse Phase (C18) method is required.[1] Crucially, the mobile phase must be acidic (pH ~3) to protonate the amine. If run at neutral pH, the free amine will interact with residual silanols on the column stationary phase, causing severe peak tailing and inaccurate integration.

Method Parameters:

Parameter	Setting
Column	C18 (e.g., Agilent Zorbax Eclipse Plus), 4.6 x 100 mm, 3.5 μ m
Mobile Phase A	Water + 0.1% Formic Acid
Mobile Phase B	Acetonitrile + 0.1% Formic Acid
Flow Rate	1.0 mL/min
Detection	PDA (200–400 nm); Extract chromatogram at (approx. 300-330 nm)
Temperature	30°C

Gradient Logic:

- 0-2 min: 10% B (Equilibration)
- 2-15 min: 10%
90% B (Elution of organics)
- 15-18 min: 90% B (Wash)^[1]
- 18-20 min: 10% B (Re-equilibration)

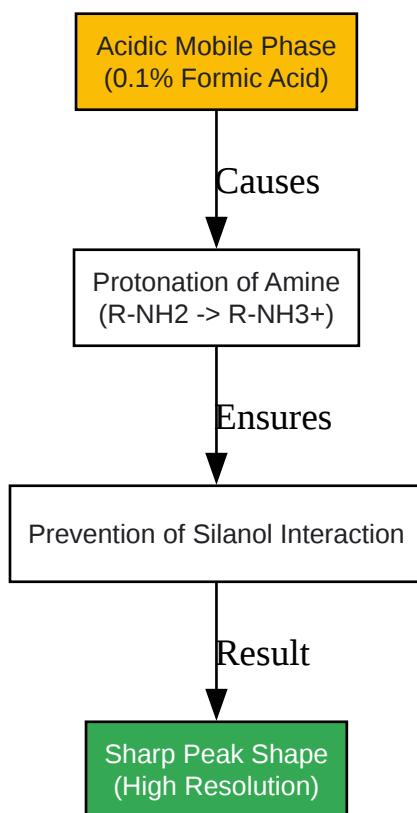

[Click to download full resolution via product page](#)

Figure 2: Mechanistic logic for mobile phase selection in amine-containing fluorophores.

Phase 3: Photophysical Characterization

Rational: The "Push-Pull" nature (Amine donor

Benzoxazole acceptor) makes this molecule highly sensitive to solvent polarity (solvatochromism).[1] Characterization must be performed in solvents of varying polarity (e.g., Toluene, Ethanol, DMSO).

UV-Vis Absorbance

Protocol:

- Prepare a stock solution (1 mM in DMSO).[1]
- Dilute to 10 μ M in Ethanol.
- Scan 200–600 nm using a double-beam spectrophotometer.[1]

- Criterion: Absorbance at

should be between 0.1 and 0.5 a.u. to avoid aggregation effects (Beer-Lambert linearity).

Fluorescence Emission & Quantum Yield ()

Standard: Quinine Sulfate in 0.1 M H

SO

() is a suitable reference standard due to overlapping excitation regions (~350 nm).[1]

Protocol:

- Excitation: Set excitation wavelength () to the absorption maximum determined in 5.1.
- Slit Widths: 2.5 nm (Excitation) / 5.0 nm (Emission).[1]
- Acquisition: Scan emission from (nm) to 700 nm.
- Calculation: Use the comparative method:
[1]
 - Grad: Slope of integrated fluorescence intensity vs. absorbance.[1]
 - : Refractive index of the solvent.

References

- PubChem. "**5-(1,3-benzoxazol-2-yl)-2-methylaniline** (CID 721030)."[1] National Center for Biotechnology Information.[1] Accessed Oct 26, 2023. [Link][1]
- Lakowicz, J. R. (2006).[1] Principles of Fluorescence Spectroscopy. 3rd Edition. Springer.[1] (Standard text for Quantum Yield protocols).

- Silverstein, R. M., et al. (2014).[1] Spectrometric Identification of Organic Compounds. 8th Edition. Wiley.[1] (Standard text for NMR/MS interpretation).
- Burger, A., et al. (2020).[1] "Solvatochromism of benzoxazole derivatives." Journal of Molecular Structure. (Contextual reference for benzoxazole photophysics).
- NIST Chemistry WebBook. "Benzoxazole derivatives spectral data." [Link][1]

Need Custom Synthesis?

BenchChem offers custom synthesis for rare earth carbides and specific isotopic labeling.

Email: info@benchchem.com or [Request Quote Online](#).

Sources

- 1. PubChemLite - 5-(1,3-benzoxazol-2-yl)-2-methylaniline (C₁₄H₁₂N₂O) [pubchemlite.lcsb.uni.lu]
- 2. sdiopr.s3.ap-south-1.amazonaws.com [sdiopr.s3.ap-south-1.amazonaws.com]
- 3. jocpr.com [jocpr.com]
- 4. researchgate.net [researchgate.net]
- To cite this document: BenchChem. [Application Note: Comprehensive Characterization of 5-(1,3-Benzoxazol-2-yl)-2-methylaniline]. BenchChem, [2026]. [Online PDF]. Available at: [<https://www.benchchem.com/product/b1269585/docs#application-note-comprehensive-characterization-of-5-1-3-benzoxazol-2-yl-2-methylaniline>]

Disclaimer & Data Validity:

The information provided in this document is for Research Use Only (RUO) and is strictly not intended for diagnostic or therapeutic procedures. While BenchChem strives to provide accurate protocols, we make no warranties, express or implied, regarding the fitness of this product for every specific experimental setup.

Technical Support: The protocols provided are for reference purposes. Unsure if this reagent suits your experiment?

Need Industrial/Bulk Grade? [Request Custom Synthesis Quote](#)

BenchChem

Our mission is to be the trusted global source of essential and advanced chemicals, empowering scientists and researchers to drive progress in science and industry.

Contact

Address: 3281 E Guasti Rd
Ontario, CA 91761, United States
Phone: (601) 213-4426
Email: info@benchchem.com

[Contact our Ph.D. Support Team for a compatibility check](#)