

Technical Support Center: 3-Bromobenzyl Chloride in Synthetic Applications

Author: BenchChem Technical Support Team. **Date:** May 2026

Compound of Interest

Compound Name: 3-Bromobenzyl chloride

CAS No.: 932-77-4

Cat. No.: B1268085

[Get Quote](#)

Introduction

3-Bromobenzyl chloride (CAS 932-77-4) is a pivotal bifunctional building block in modern organic synthesis, prized for its utility in constructing complex molecular architectures. Its benzylic chloride moiety serves as a reactive electrophile for nucleophilic substitutions, while the bromo-substituted aromatic ring is amenable to a variety of cross-coupling reactions. This dual reactivity, however, necessitates a nuanced understanding of its chemistry to mitigate potential side reactions and byproduct formation.

This technical support guide is designed for researchers, scientists, and drug development professionals. It provides in-depth troubleshooting advice and answers to frequently asked questions encountered during the experimental use of **3-Bromobenzyl chloride**. Our goal is to empower you with the expertise to anticipate and resolve common challenges, ensuring the efficiency and reproducibility of your synthetic endeavors.

Part 1: Troubleshooting Guide

This section addresses specific issues that may arise during reactions involving **3-Bromobenzyl chloride**, offering explanations for their root causes and providing actionable,

step-by-step protocols for their resolution.

Issue 1: Formation of Dimeric Byproduct (1,2-bis(3-bromophenyl)ethane)

Problem: You observe a significant amount of a high-molecular-weight byproduct, identified as the dimer of **3-Bromobenzyl chloride**, particularly in reactions involving metals (e.g., Grignard reagent formation, Wurtz-type couplings).

Root Cause Analysis: This homocoupling side reaction, often referred to as a Wurtz or Wurtz-Fittig type reaction, is a common issue when using organometallic reagents or reactive metals with benzylic halides.^{[1][2]} The reaction proceeds through the formation of a benzylic radical or an organometallic intermediate which then reacts with another molecule of **3-Bromobenzyl chloride**.^{[2][3]}

Troubleshooting Protocol:

- Optimize Grignard Formation Conditions:
 - Slow Addition: Add the **3-Bromobenzyl chloride** solution dropwise to the magnesium turnings at a rate that maintains a gentle reflux. This keeps the concentration of the halide low in the presence of the formed Grignard reagent, minimizing the Wurtz coupling.^[4]
 - Solvent Choice: Ethereal solvents like diethyl ether or 2-methyltetrahydrofuran (2-MeTHF) can improve the product-to-byproduct ratio compared to tetrahydrofuran (THF).^[4]
 - Continuous Flow: For larger scale reactions, consider a continuous flow setup where the halide and magnesium are reacted in a packed-bed reactor. This minimizes contact time between the Grignard reagent and the unreacted halide.^[4]
- Alternative Coupling Strategies:
 - If the desired reaction is a homocoupling, consider alternative, higher-yield methods such as those employing photoredox catalysis which can be more selective.

Visualizing the Wurtz Coupling Side Reaction:

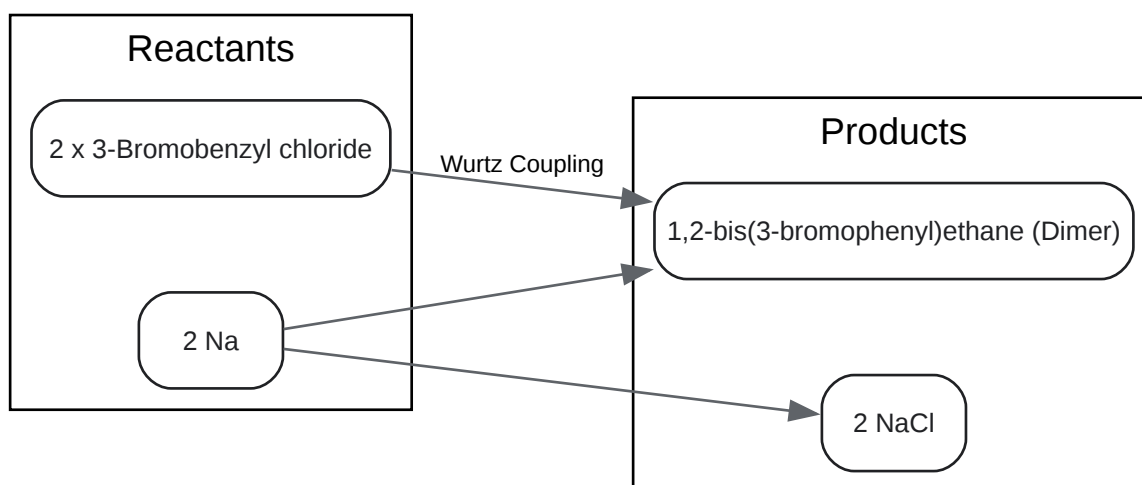

[Click to download full resolution via product page](#)

Caption: Wurtz coupling of **3-Bromobenzyl chloride**.

Issue 2: Polyalkylation and Isomerization in Friedel-Crafts Reactions

Problem: When performing a Friedel-Crafts alkylation of an aromatic substrate with **3-Bromobenzyl chloride**, you observe the formation of di- or poly-benzylated products and potentially rearranged isomers.

Root Cause Analysis:

- Polyalkylation: The initial benzylation of the aromatic ring introduces an activating alkyl group, making the product more nucleophilic than the starting material. This leads to subsequent alkylations.^{[5][6]}
- Carbocation Rearrangement: Although less common with benzylic halides compared to other primary alkyl halides, under forcing conditions, the benzylic carbocation intermediate can potentially rearrange.^{[7][8]}

Troubleshooting Protocol:

- Control Stoichiometry:

- Use a large excess of the aromatic substrate relative to the **3-Bromobenzyl chloride**. This statistical approach increases the probability of the electrophile reacting with the starting material rather than the benzylated product.[9]
- Modify Reaction Conditions:
 - Lower Temperature: Running the reaction at a lower temperature can reduce the rate of the second alkylation.[6]
 - Milder Lewis Acid: Consider using a less reactive Lewis acid catalyst.
- Alternative Two-Step Procedure (Acylation-Reduction):
 - To completely avoid these issues, the most robust solution is to perform a Friedel-Crafts acylation with 3-bromobenzoyl chloride, followed by a reduction (e.g., Clemmensen or Wolff-Kishner) of the resulting ketone. The acyl group is deactivating, which prevents polyacylation, and the acylium ion intermediate does not rearrange.[7][10]

Decision Workflow for Friedel-Crafts Alkylation:

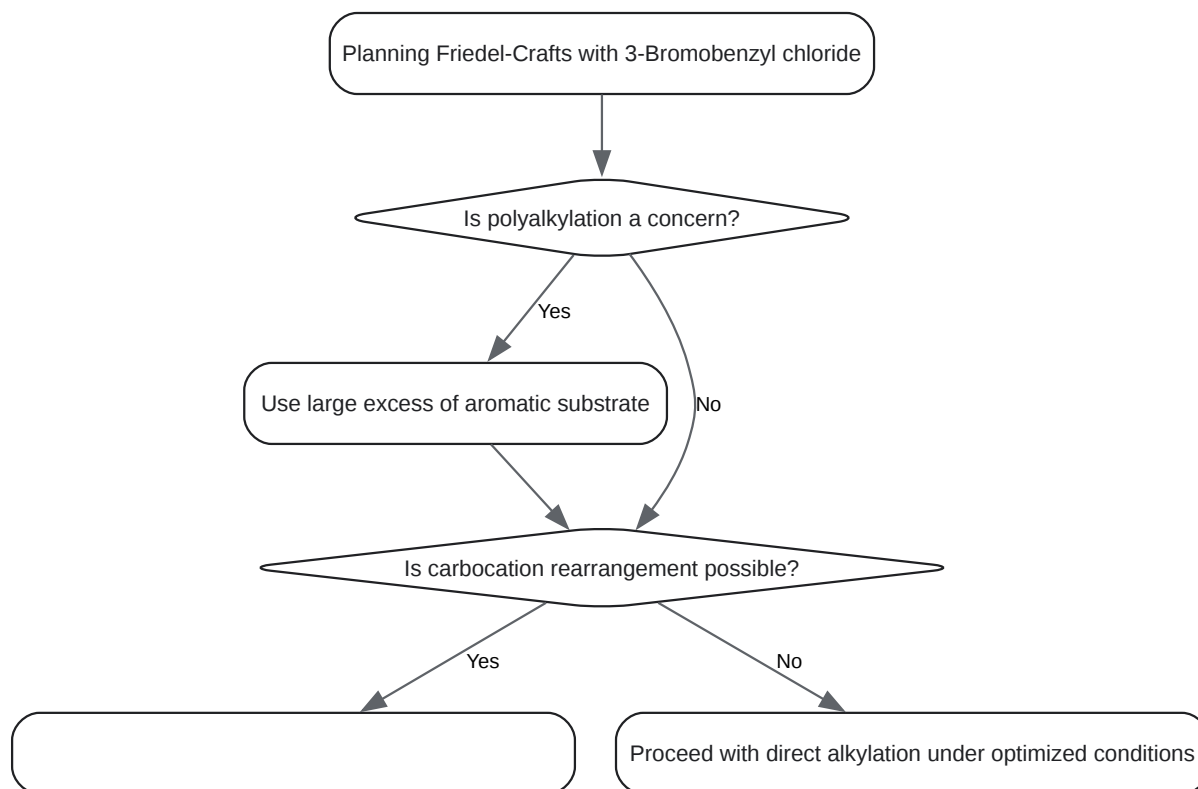

[Click to download full resolution via product page](#)

Caption: Troubleshooting Friedel-Crafts alkylation.

Issue 3: Unexpected Formation of 3-Bromobenzyl Alcohol and 3-Bromobenzaldehyde

Problem: Your reaction mixture contains 3-bromobenzyl alcohol and/or 3-bromobenzaldehyde as byproducts, leading to reduced yield of the desired product and purification challenges.

Root Cause Analysis:

- Hydrolysis: **3-Bromobenzyl chloride** is susceptible to hydrolysis, reacting with water to form 3-bromobenzyl alcohol.^[11] This can occur if the reaction is not performed under strictly anhydrous conditions, or during aqueous workup.

- Oxidation: The benzylic position is prone to oxidation, which can convert **3-Bromobenzyl chloride** or the intermediate alcohol to 3-bromobenzaldehyde.[12][13] This can be initiated by certain reagents or prolonged exposure to air at elevated temperatures.

Troubleshooting Protocol:

- Ensure Anhydrous Conditions:
 - Thoroughly dry all glassware before use.
 - Use anhydrous solvents.
 - Perform the reaction under an inert atmosphere (e.g., nitrogen or argon).
- Careful Workup:
 - If an aqueous workup is necessary, perform it at low temperatures and as quickly as possible.
 - Use a buffered aqueous solution if your product is sensitive to pH changes that could catalyze hydrolysis.
- Storage and Handling:
 - Store **3-Bromobenzyl chloride** in a tightly sealed container in a cool, dry place, away from moisture.
 - Minimize its exposure to air, especially when heated.

Table 1: Properties of Common Byproducts

Compound	Molecular Formula	Molar Mass (g/mol)	Boiling Point (°C)
3-Bromobenzyl chloride	C ₇ H ₆ BrCl	205.48	116-118 (at 17 mmHg)[14]
3-Bromobenzyl alcohol	C ₇ H ₇ BrO	187.03	165 (at 16 mmHg)[15]
3-Bromobenzaldehyde	C ₇ H ₅ BrO	185.02	233-236[16]
1,2-bis(3-bromophenyl)ethane	C ₁₄ H ₁₂ Br ₂	340.05	-

Part 2: Frequently Asked Questions (FAQs)

Q1: My nucleophilic substitution reaction with **3-Bromobenzyl chloride** is slow. How can I improve the reaction rate?

A1: The reactivity of **3-Bromobenzyl chloride** in nucleophilic substitution is generally high due to the stability of the benzylic carbocation-like transition state.[17] If the reaction is slow, consider the following:

- **Nucleophile Strength:** A stronger nucleophile will increase the reaction rate for an S_N2 reaction.
- **Solvent:** A polar aprotic solvent (e.g., DMF, DMSO, acetone) is generally preferred for S_N2 reactions as it solvates the cation but not the nucleophile, increasing its reactivity.
- **Temperature:** Increasing the reaction temperature will generally increase the reaction rate. However, be mindful of potential side reactions at higher temperatures.
- **Leaving Group:** While the chloride is a good leaving group, you could consider converting it to the more reactive 3-bromobenzyl iodide in situ by adding a catalytic amount of sodium iodide (Finkelstein reaction).

Q2: What are the common impurities in commercially available **3-Bromobenzyl chloride** and how can they affect my reaction?

A2: Commercial **3-Bromobenzyl chloride** can contain impurities from its synthesis, such as unreacted starting materials or over-halogenated products.^[18] The presence of di- or tri-chlorinated species can lead to the formation of undesired byproducts in your reaction. The presence of acidic impurities like HCl can also catalyze side reactions. It is crucial to source high-purity starting materials and, if necessary, purify the reagent before use, for example, by vacuum distillation.^[18]

Q3: Can I use **3-Bromobenzyl chloride** for both nucleophilic substitution at the benzylic position and a cross-coupling reaction on the aromatic ring in the same synthetic sequence?

A3: Yes, this is one of the key advantages of this reagent.^[19] The order of reactions is critical. Typically, the nucleophilic substitution at the more reactive benzylic chloride position is performed first. The resulting product, now containing the new functional group, can then be subjected to a palladium-catalyzed cross-coupling reaction (e.g., Suzuki, Heck, Sonogashira) at the aryl bromide position.

Q4: How can I effectively purify my product from unreacted **3-Bromobenzyl chloride**?

A4:

- Chromatography: Column chromatography is a very effective method for separating polar products from the less polar **3-Bromobenzyl chloride**.
- Crystallization: If your product is a solid, crystallization can be an excellent purification technique.^[20]
- Distillation: If your product has a significantly different boiling point from **3-Bromobenzyl chloride**, vacuum distillation can be employed.
- Chemical Quenching: If your product is stable to basic conditions, you can quench the reaction mixture with an amine (e.g., aqueous ammonia) to convert the unreacted **3-Bromobenzyl chloride** into the more polar and easily separable benzylamine derivative.^[21]

References

- Optimizing Your Buy: **3-Bromobenzyl Chloride** Purity and Manufacturer Reliability. (2025). Global Chemical Sourcing. [\[Link\]](#)
- 3-Bromobenzaldehyde (C₇H₅BrO) properties. WebQC.org. [\[Link\]](#)
- 16.3: Alkylation and Acylation of Aromatic Rings - The Friedel-Crafts Reaction. (2022). Chemistry LibreTexts. [\[Link\]](#)
- Friedel-Crafts Alkylation with Practice Problems. (2022). Chemistry Steps. [\[Link\]](#)
- Wurtz reaction. Grokipedia. [\[Link\]](#)
- Wurtz reaction. Wikipedia. [\[Link\]](#)
- Wurtz Reaction. Organic Chemistry Portal. [\[Link\]](#)
- Friedel Crafts Alkylation of Benzene Reaction Mechanism - Tons of Examples! (2018). YouTube. [\[Link\]](#)
- What Makes Friedel-Crafts Reactions So Tricky? (2022). YouTube. [\[Link\]](#)
- Wurtz Coupling Reaction. Scribd. [\[Link\]](#)
- 3-Bromobenzaldehyde. Wikipedia. [\[Link\]](#)
- Bromobenzyl Cyanide. PubChem. [\[Link\]](#)
- Purification of Organic Compounds: from Crude Product to Purity. (2023). EMU Physics Department. [\[Link\]](#)
- US4036887A - Preparation of 3-bromobenzaldehyde.
- Preparation, Hydrolysis and Reduction of the Fluoro-, Chloro-, and Bromo-benzyl Bromides. (1926). RSC Publishing. [\[Link\]](#)
- CONVENIENT METHOD FOR OXIDATION OF BENZYL HALIDES TO BENZALDEHYDE WITH SODIUM NITRATE IN IONIC LIQUID. (2022). RJPN. [\[Link\]](#)

- EAS Reactions (3) - Friedel-Crafts Acylation and Friedel-Crafts Alkylation. (2018). Master Organic Chemistry. [[Link](#)]
- Can we use 2 different alkyl halides (e.g. CH₃-Cl and CH₃-CH₂-CH₂-Br) in the Wurtz reaction? (2018). Quora. [[Link](#)]
- 3.2: Purification of Products. (2025). Chemistry LibreTexts. [[Link](#)]
- Friedel–Crafts Acylation & Solutions to F–C Alkylation Problems. (2017). YouTube. [[Link](#)]
- Synthesis of 3-bromobenzaldehyde. PrepChem.com. [[Link](#)]
- Solvent screening of benzyl chloride Grignard reaction. ResearchGate. [[Link](#)]
- Nucleophilic Aromatic Substitution: Introduction and Addition-Elimination Mechanism. (2023). YouTube. [[Link](#)]
- US3557222A - Hydrolysis of benzyl chloride to benzyl alcohol.
- 3-Bromobenzyl alcohol. SIELC Technologies. [[Link](#)]
- 3-Bromobenzyl alcohol. PubChem. [[Link](#)]
- The Versatile Role of **3-Bromobenzyl Chloride** in Advanced Organic Synthesis. (n.d.). LinkedIn. [[Link](#)]
- What happens when 2-Bromobenzyl chloride reacts with Sodium methoxide in a methanol medium? (2017). Quora. [[Link](#)]
- DE4439003C1 - Grignard reagents comprising benzyl-magnesium halide.
- Reactions of Grignard Reagents. (2015). Master Organic Chemistry. [[Link](#)]
- Reactivity, SCE induction and mutagenicity of benzyl chloride derivatives. (1983). PubMed. [[Link](#)]
- CN100543003C - A kind of preparation method of p-bromobenzyl bromide.
- AN INTRODUCTION TO GRIGNARD REAGENTS. Chemguide. [[Link](#)]

- NUCLEOPHILIC AROMATIC SUBSTITUTION. NCRD's Sterling Institute of Pharmacy. [[Link](#)]
- Grignard Reagent Reaction Mechanism. (2018). YouTube. [[Link](#)]
- 7.1: Nucleophilic Substitution Reaction Overview. (2021). Chemistry LibreTexts. [[Link](#)]
- 16.6: Nucleophilic Aromatic Substitution. (2025). Chemistry LibreTexts. [[Link](#)]

Need Custom Synthesis?

BenchChem offers custom synthesis for rare earth carbides and specific isotopic labeling.

Email: info@benchchem.com or [Request Quote Online](#).

Sources

- 1. grokipedia.com [grokipedia.com]
- 2. [Wurtz reaction - Wikipedia](https://en.wikipedia.org/wiki/Wurtz_reaction) [en.wikipedia.org]
- 3. scribd.com [scribd.com]
- 4. researchgate.net [researchgate.net]
- 5. chem.libretexts.org [chem.libretexts.org]
- 6. pdf.benchchem.com [pdf.benchchem.com]
- 7. [Friedel-Crafts Alkylation with Practice Problems - Chemistry Steps](https://chemistrysteps.com) [chemistrysteps.com]
- 8. masterorganicchemistry.com [masterorganicchemistry.com]
- 9. pdf.benchchem.com [pdf.benchchem.com]
- 10. m.youtube.com [m.youtube.com]
- 11. [US3557222A - Hydrolysis of benzyl chloride to benzyl alcohol - Google Patents](https://patents.google.com/patent/US3557222A) [patents.google.com]
- 12. webqc.org [webqc.org]
- 13. rjpn.org [rjpn.org]
- 14. [3-溴苄氯 98% | Sigma-Aldrich](https://sigmaaldrich.com) [sigmaaldrich.com]
- 15. [3-Bromobenzyl alcohol 99 15852-73-0](https://sigmaaldrich.com) [sigmaaldrich.com]
- 16. [3-Bromobenzaldehyde - Wikipedia](https://en.wikipedia.org/wiki/3-Bromobenzaldehyde) [en.wikipedia.org]

- [17. pdf.benchchem.com \[pdf.benchchem.com\]](#)
- [18. nbinno.com \[nbinno.com\]](#)
- [19. nbinno.com \[nbinno.com\]](#)
- [20. chem.libretexts.org \[chem.libretexts.org\]](#)
- [21. pdf.benchchem.com \[pdf.benchchem.com\]](#)
- To cite this document: BenchChem. [Technical Support Center: 3-Bromobenzyl Chloride in Synthetic Applications]. BenchChem, [2026]. [Online PDF]. Available at: [\[https://www.benchchem.com/product/b1268085/docs#technical-support-center-3-bromobenzyl-chloride-in-synthetic-applications\]](https://www.benchchem.com/product/b1268085/docs#technical-support-center-3-bromobenzyl-chloride-in-synthetic-applications)

Disclaimer & Data Validity:

The information provided in this document is for Research Use Only (RUO) and is strictly not intended for diagnostic or therapeutic procedures. While BenchChem strives to provide accurate protocols, we make no warranties, express or implied, regarding the fitness of this product for every specific experimental setup.

Technical Support: The protocols provided are for reference purposes. Unsure if this reagent suits your experiment?

Need Industrial/Bulk Grade? [Request Custom Synthesis Quote](#)

BenchChem

Our mission is to be the trusted global source of essential and advanced chemicals, empowering scientists and researchers to drive progress in science and industry.

Contact

Address: 3281 E Guasti Rd
Ontario, CA 91761, United States
Phone: (601) 213-4426
Email: info@benchchem.com

Contact our Ph.D. Support Team for a compatibility check