

Preventing protodeboronation in Suzuki reactions of thienopyridines

Author: BenchChem Technical Support Team. **Date:** December 2025

Compound of Interest

Compound Name: 3-Bromothieno[3,2-c]pyridine

Cat. No.: B1268464

[Get Quote](#)

Technical Support Center: Suzuki Reactions of Thienopyridines

This technical support center provides troubleshooting guidance and frequently asked questions (FAQs) to assist researchers, scientists, and drug development professionals in overcoming challenges associated with protodeboronation in Suzuki-Miyaura cross-coupling reactions of thienopyridines.

Frequently Asked Questions (FAQs)

Q1: What is protodeboronation and why is it a significant problem in Suzuki reactions of thienopyridines?

A1: Protodeboronation is an undesired side reaction in which the carbon-boron bond of the thienopyridine boronic acid or ester is cleaved and replaced by a carbon-hydrogen bond.[1][2] This reaction consumes the boronic acid reagent, leading to a reduced yield of the desired coupled product and the formation of a thienopyridine byproduct, which can complicate purification.[3] Thienopyridines, like other electron-deficient heteroaromatic systems, can be particularly susceptible to this decomposition pathway.[4][5]

Q2: What are the primary factors that contribute to protodeboronation?

A2: Several factors can influence the rate of protodeboronation in Suzuki reactions of thienopyridines:

- Reaction Temperature: Higher temperatures can accelerate the rate of protodeboronation.^[4]^[6]
- Choice of Base: The type and concentration of the base are critical. While a base is necessary for the catalytic cycle, strongly basic conditions, especially in the presence of water, can promote protodeboronation.^[1]^[7]^[8]
- Catalyst System: The efficiency of the palladium catalyst and its ligands plays a crucial role. A highly active catalyst that promotes rapid cross-coupling can outcompete the slower protodeboronation side reaction.^[2]^[8]
- Solvent: The presence of a proton source, such as water or alcohol, in the solvent system is necessary for protodeboronation to occur.^[4]
- Nature of the Boronic Acid Derivative: Unprotected boronic acids are generally more susceptible to protodeboronation than their corresponding boronate esters, such as pinacol or MIDA esters.^[2]^[4]

Q3: How can I minimize protodeboronation in my Suzuki reaction of a thienopyridine?

A3: Several strategies can be employed to mitigate protodeboronation:

- Use Boronic Esters: Converting the thienopyridine boronic acid to a more stable boronic ester, such as a pinacol ester or an N-methyliminodiacetic acid (MIDA) boronate, is a highly effective strategy.^[2]^[4] These esters exhibit increased stability and can facilitate a "slow release" of the active boronic acid under the reaction conditions, keeping its concentration low and minimizing decomposition.^[2]^[9]
- Optimize the Base: Use a milder base. Instead of strong bases like sodium hydroxide (NaOH), consider weaker inorganic bases such as potassium carbonate (K_2CO_3), cesium carbonate (Cs_2CO_3), potassium phosphate (K_3PO_4), or potassium fluoride (KF).^[4]^[5]
- Control the Temperature: If the catalyst system is sufficiently active, running the reaction at a lower temperature (e.g., room temperature to 80 °C) can significantly reduce the rate of

protodeboronation.[4][6]

- **Employ a Highly Active Catalyst:** Using a highly efficient palladium catalyst with bulky, electron-rich phosphine ligands (e.g., SPhos, XPhos) can accelerate the desired cross-coupling reaction to outcompete protodeboronation.[8][10]
- **Anhydrous Conditions:** While Suzuki reactions often benefit from some water, using anhydrous solvents can minimize the primary proton source for protodeboronation.[4] However, this may require careful optimization as completely anhydrous conditions can sometimes slow down the desired coupling.

Troubleshooting Guide

Problem	Potential Cause	Troubleshooting Steps
Low yield of desired product and significant amount of protodeboronated thienopyridine	High rate of protodeboronation.	<p>1. Switch to a boronic ester: If using a boronic acid, convert it to a pinacol or MIDA boronate ester.^[2]^[4] 2. Use a milder base: Replace strong bases (e.g., NaOH, KOH) with weaker ones (e.g., K₂CO₃, K₃PO₄, Cs₂CO₃).^[4] 3. Lower the reaction temperature: Attempt the reaction at a lower temperature (e.g., 60-80 °C).^[4] 4. Use a more active catalyst: Employ a catalyst system known for high activity at lower temperatures, such as those with Buchwald-type ligands.^[10] 5. Consider anhydrous conditions: Minimize water in the reaction by using dry solvents and reagents.^[4]</p>
Reaction is sluggish or incomplete	Poor catalyst activity or deactivation.	<p>1. Ensure an inert atmosphere: Thoroughly degas the solvent and reagents and maintain the reaction under an inert atmosphere (e.g., nitrogen or argon) to prevent catalyst oxidation. 2. Check catalyst and ligand quality: Use fresh, high-purity catalyst and ligands. 3. Increase catalyst loading: A modest increase in catalyst loading (e.g., from 1-2 mol% to 3-5 mol%) may improve conversion.^[11]</p>

Formation of homocoupled byproducts

Presence of oxygen.

1. Thoroughly degas all solvents and reagents. 2. Maintain a positive pressure of an inert gas (argon or nitrogen) throughout the reaction setup and duration.

Quantitative Data Summary

The following tables summarize typical reaction conditions that can be used as a starting point for optimizing Suzuki-Miyaura couplings of thienopyridines to minimize protodeboronation.

Table 1: Recommended Reaction Parameters to Minimize Protodeboronation

Parameter	Recommended Condition	Rationale
Boron Reagent	Thienopyridine Pinacol Boronate or MIDA Boronate	Increased stability compared to the corresponding boronic acid, allowing for "slow release" of the active nucleophile.[2][9]
Palladium Catalyst	Pd(OAc) ₂ with a bulky phosphine ligand (e.g., SPhos, XPhos) or a pre-formed catalyst like Pd(dppf)Cl ₂ . Catalyst loading: 2-5 mol%.	Highly active catalysts promote the desired coupling at a faster rate than protodeboronation. [10][12]
Base	K ₃ PO ₄ , K ₂ CO ₃ , or Cs ₂ CO ₃ (2.0-3.0 equivalents)	Weaker bases reduce the rate of base-catalyzed protodeboronation.[1][4]
Solvent	1,4-Dioxane/H ₂ O (e.g., 10:1), Toluene, or THF (anhydrous if necessary)	Minimizes the proton source for the side reaction.[4]
Temperature	60-100 °C	Lower temperatures slow the rate of protodeboronation.[4]

Experimental Protocols

General Protocol for Suzuki-Miyaura Coupling of a Halogenated Thienopyridine with an Arylboronic Acid Derivative

This protocol is a general starting point and should be optimized for specific substrates.

Materials:

- Halogenated thienopyridine (1.0 equiv)
- Thienopyridine boronic acid pinacol ester (1.2-1.5 equiv)
- Palladium catalyst (e.g., Pd(dppf)Cl₂, 2-5 mol%)
- Base (e.g., K₂CO₃, 2.0-3.0 equiv)
- Degassed solvent (e.g., 1,4-dioxane/water 10:1)
- Inert gas (Argon or Nitrogen)
- Standard laboratory glassware for inert atmosphere reactions (e.g., Schlenk flask)

Procedure:

- **Reaction Setup:** To an oven-dried Schlenk flask containing a magnetic stir bar, add the halogenated thienopyridine (1.0 equiv), the thienopyridine boronic acid pinacol ester (1.2-1.5 equiv), and the base (2.0-3.0 equiv).
- **Inert Atmosphere:** Seal the flask with a septum and evacuate and backfill with an inert gas (argon or nitrogen) for three cycles to ensure an oxygen-free environment.
- **Catalyst Addition:** Under a positive flow of inert gas, add the palladium catalyst (2-5 mol%).
- **Solvent Addition:** Add the degassed solvent via syringe.

- Reaction: Place the flask in a preheated oil bath at the desired temperature (e.g., 80-100 °C) and stir the reaction mixture vigorously.
- Monitoring: Monitor the progress of the reaction by thin-layer chromatography (TLC) or liquid chromatography-mass spectrometry (LC-MS).
- Work-up: Upon completion, cool the reaction mixture to room temperature. Dilute the mixture with an organic solvent (e.g., ethyl acetate) and wash with water and brine.
- Purification: Dry the organic layer over anhydrous sodium sulfate, filter, and concentrate under reduced pressure. Purify the crude product by flash column chromatography.

Visualizations

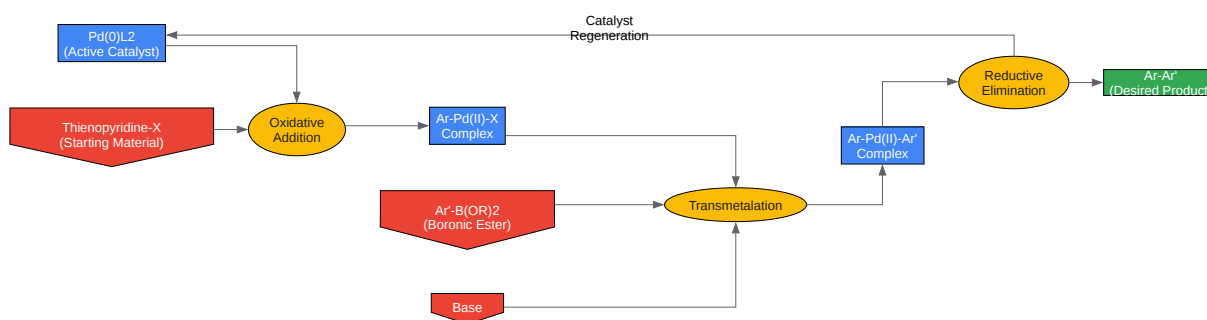

[Click to download full resolution via product page](#)

Caption: The catalytic cycle of the Suzuki-Miyaura cross-coupling reaction.

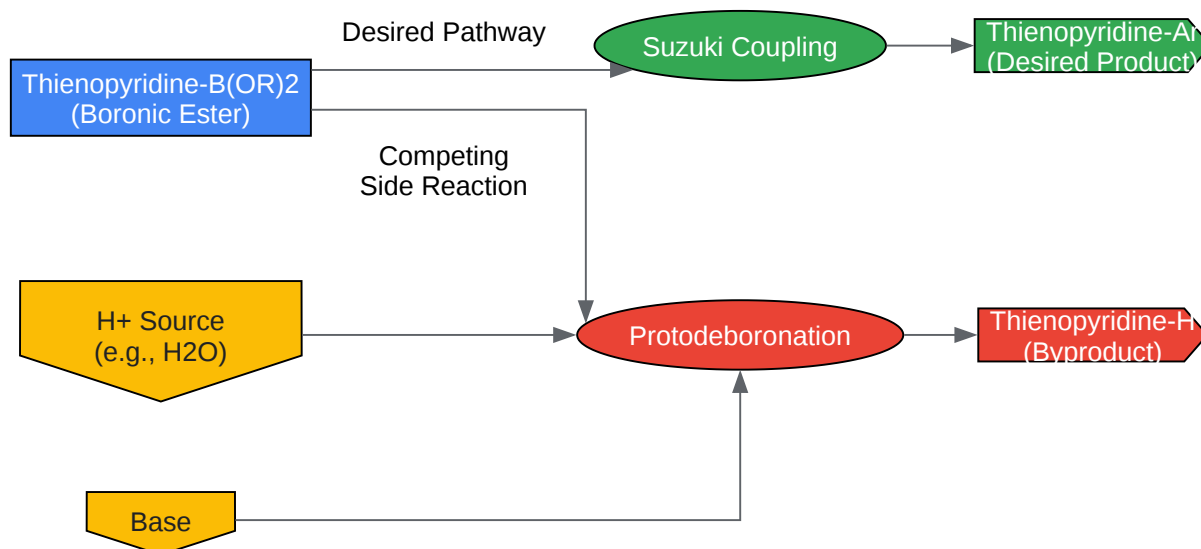

[Click to download full resolution via product page](#)

Caption: Competing pathways: Suzuki coupling versus protodeboronation.

Need Custom Synthesis?

BenchChem offers custom synthesis for rare earth carbides and specific isotopic labeling.

Email: info@benchchem.com or [Request Quote Online](#).

References

- 1. researchgate.net [researchgate.net]
- 2. Protodeboronation - Wikipedia [en.wikipedia.org]
- 3. A Simple Synthesis of Some New Thienopyridine and Thieno-pyrimidine Derivatives - PMC [pmc.ncbi.nlm.nih.gov]
- 4. benchchem.com [benchchem.com]
- 5. A General and Efficient Method for the Suzuki-Miyaura Coupling of 2-Pyridyl Nucleophiles - PMC [pmc.ncbi.nlm.nih.gov]

- 6. reddit.com [reddit.com]
- 7. researchgate.net [researchgate.net]
- 8. chemrxiv.org [chemrxiv.org]
- 9. research-information.bris.ac.uk [research-information.bris.ac.uk]
- 10. benchchem.com [benchchem.com]
- 11. mdpi.com [mdpi.com]
- 12. benchchem.com [benchchem.com]
- To cite this document: BenchChem. [Preventing protodeboronation in Suzuki reactions of thienopyridines]. BenchChem, [2025]. [Online PDF]. Available at: [https://www.benchchem.com/product/b1268464#preventing-protodeboronation-in-suzuki-reactions-of-thienopyridines]

Disclaimer & Data Validity:

The information provided in this document is for Research Use Only (RUO) and is strictly not intended for diagnostic or therapeutic procedures. While BenchChem strives to provide accurate protocols, we make no warranties, express or implied, regarding the fitness of this product for every specific experimental setup.

Technical Support: The protocols provided are for reference purposes. Unsure if this reagent suits your experiment? [[Contact our Ph.D. Support Team for a compatibility check](#)]

Need Industrial/Bulk Grade? [Request Custom Synthesis Quote](#)

BenchChem

Our mission is to be the trusted global source of essential and advanced chemicals, empowering scientists and researchers to drive progress in science and industry.

Contact

Address: 3281 E Guasti Rd

Ontario, CA 91761, United States

Phone: (601) 213-4426

Email: info@benchchem.com