

A Comparative Guide to Alternative Intermediates in the Synthesis of Ranlukast

Author: BenchChem Technical Support Team. **Date:** May 2026

Compound of Interest

Compound Name: 1-(3-Amino-2-hydroxyphenyl)ethanone

CAS No.: 70977-72-9

Cat. No.: B1268288

[Get Quote](#)

Introduction

Ranlukast, a potent and selective cysteinyl leukotriene C4/D4 receptor antagonist, is a crucial therapeutic agent for managing asthma and allergic rhinitis.[1][2] Its synthesis has been a subject of considerable research, aiming to enhance efficiency, reduce costs, and improve the environmental footprint of its production. At the heart of these process improvements lies the exploration of alternative intermediates. This guide provides an in-depth comparison of conventional and alternative intermediates in ranlukast synthesis, offering experimental insights and data to inform researchers and drug development professionals.

The core structure of ranlukast, N-[4-Oxo-2-(1H-tetrazol-5-yl)-4H-chromen-8-yl]-4-(4-phenylbutoxy)-benzamide, is typically assembled from two key fragments: the chromone core and the phenylbutoxybenzoyl side chain.[3][4][5] The traditional synthetic routes have relied on a well-established set of intermediates, but challenges related to yield, purity, and scalability have spurred the investigation of novel synthetic pathways.[1][6]

The Conventional Synthetic Pathway: A Critical Assessment

The benchmark synthesis of ranlukast involves the coupling of two primary intermediates: 8-amino-4-oxo-2-(1H-tetrazol-5-yl)-4H-1-benzopyran (the chromone core) and 4-(4-phenylbutoxy)benzoic acid (the side chain).^{[3][6]} This approach, while effective, presents several areas for optimization.

A common route to the chromone core starts from 3-Amino-2-hydroxyacetophenone.^[6] This key starting material undergoes a series of reactions, including the introduction of the tetrazole moiety, to form the final benzopyran structure.^{[6][7]} The side chain, 4-(4-phenylbutoxy)benzoic acid, is typically prepared via a Williamson ether synthesis involving 1-Bromo-4-phenylbutane.^{[3][6]}

Challenges in the Conventional Route:

- **Multi-step Synthesis of the Chromone Core:** The formation of 8-amino-4-oxo-2-(tetrazol-5-yl)-4H-1-benzopyran can be low-yielding and require stringent purification steps.^[8]
- **Availability and Purity of Starting Materials:** The quality of initial materials like 1-Bromo-4-phenylbutane can vary, impacting the overall efficiency and cost of the synthesis.^[6]
- **Process Safety and Environmental Concerns:** The use of certain reagents and solvents in the conventional pathway may not align with modern green chemistry principles, prompting a search for more sustainable alternatives.^{[9][10]}

Visualizing the Conventional Pathway

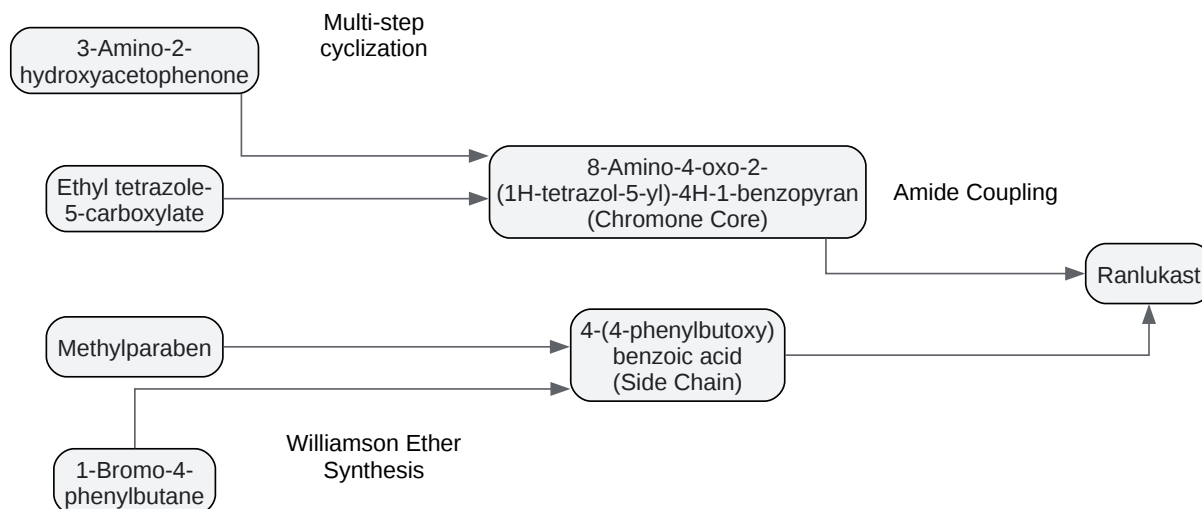

[Click to download full resolution via product page](#)

Caption: Conventional synthesis of Ranlukast.

Alternative Intermediates and Novel Synthetic Strategies

To address the limitations of the conventional route, researchers have explored several alternative intermediates and synthetic designs. These innovations primarily focus on simplifying the synthesis, improving yields, and utilizing more readily available or cost-effective starting materials.

Alternative 1: Pre-functionalized Acetophenone Intermediate

One notable alternative involves the use of 3-[4-(4-phenylbutoxy)benzoylamino]-2-hydroxyacetophenone.^{[6][11]} In this strategy, the phenylbutoxybenzoyl side chain is attached to the 3-amino-2-hydroxyacetophenone precursor before the formation of the chromone ring.

Advantages:

- **Convergent Synthesis:** This approach can lead to a more convergent synthesis, potentially reducing the total number of steps.
- **Improved Solubility and Handling:** The larger, pre-functionalized intermediate may exhibit different solubility properties, facilitating purification.

Experimental Protocol: Synthesis via 3-[4-(4-phenylbutoxy)benzoylamino]-2-hydroxyacetophenone

- **Amide Formation:** React 4-(4-phenylbutoxy)benzoic acid with 3-amino-2-hydroxyacetophenone in the presence of a coupling agent (e.g., DCC/DMAP or EDCI/HOBt) in a suitable solvent like dichloromethane or DMF to yield 3-[4-(4-phenylbutoxy)benzoylamino]-2-hydroxyacetophenone.
- **Cyclization:** The resulting intermediate is then reacted with a tetrazole-forming reagent, such as 1H-tetrazol-5-ethyl formate, in the presence of a strong base like potassium tert-butoxide. [3]
- **Workup and Purification:** The reaction mixture is acidified to precipitate the crude ranlukast, which is then purified by recrystallization. [3][11]

Alternative 2: Novel Route to 4-(4-phenylbutoxy)benzoic acid

The synthesis of the side chain intermediate itself has been a target for optimization. A novel route starting from β -bromophenylethane has been proposed to circumvent issues with the availability and preparation of 4-chloro-1-butanol, a precursor in some traditional syntheses. [1]

Synthetic Scheme:

This route involves a Grignard reaction with β -bromophenylethane, followed by reaction with ethylene oxide, mesylation, substitution, and finally hydrolysis to obtain 4-(4-phenylbutoxy)benzoic acid. [1]

Advantages:

- Cost-Effective Starting Material: β -bromophenylethane is an inexpensive and readily available raw material.[1]
- High Purity and Yield: This pathway is reported to produce high-purity 4-(4-phenylbutoxy)benzoic acid in good yield, making it suitable for industrial-scale production.[1]

Visualizing an Alternative Pathway

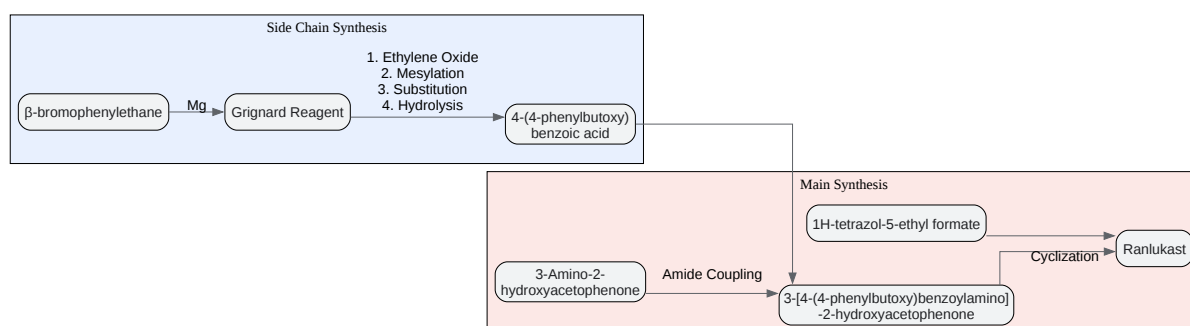

[Click to download full resolution via product page](#)

Caption: An alternative, convergent synthesis of Ranlukast.

Comparative Analysis

The choice of synthetic route and intermediates has significant implications for the overall efficiency and cost-effectiveness of ranlukast production. Below is a comparative summary based on reported data.

Parameter	Conventional Route	Alternative Route 1 (Pre-functionalized)	Alternative Route 2 (Novel Side Chain)
Key Intermediate	8-amino-4-oxo-2-(1H-tetrazol-5-yl)-4H-1-benzopyran	3-[4-(4-phenylbutoxy)benzoyl amino]-2-hydroxyacetophenone	4-(4-phenylbutoxy)benzoic acid (from β -bromophenylethane)
Overall Yield	Reported as ~24.7% [3]	Reported as high as 85% for the final cyclization step[11]	High yield for the side chain synthesis reported[1]
Number of Steps	Can be linear and lengthy	Potentially more convergent	Shortens the technology route for the side chain[1]
Starting Materials	May require less common or variable purity materials[6]	Utilizes common coupling reagents	Starts from cheap and available raw materials[1]
Scalability	Established but with potential for optimization	Favorable due to convergence	Suitable for industrial production[1]
Green Chemistry	May involve less desirable solvents and reagents	Can be optimized for greener conditions	Offers a potentially more sustainable side chain synthesis

Conclusion and Future Outlook

The synthesis of ranlukast is a mature field, yet it continues to evolve with the introduction of innovative synthetic routes and alternative intermediates. The shift towards more convergent strategies, such as pre-functionalizing the acetophenone core, offers significant advantages in terms of yield and process efficiency.[11] Furthermore, optimizing the synthesis of key building blocks like 4-(4-phenylbutoxy)benzoic acid from more economical and readily available starting materials presents a clear path to reducing manufacturing costs.[1]

Future research will likely focus on the integration of green chemistry principles, such as the use of biocatalysis or flow chemistry, to further enhance the sustainability of ranlukast

production.[10] The continued exploration of novel synthetic pathways will be crucial for ensuring the long-term, cost-effective supply of this important therapeutic agent.

References

- Google Patents. (n.d.). JP2007231019A - Process for producing 8-amino-4-oxo-2-(tetrazol-5-yl)-4H-1-benzopyran or salt thereof.
- European Patent Office. (1996). PROCESS FOR PRODUCING 2-(TETRAZOL-5-YL)-4-OXO-4H-BENZOPYRANS. Retrieved from [\[Link\]](#)
- ResearchGate. (n.d.). Optimization of the synthesis of Pranlukast intermediate. Retrieved from [\[Link\]](#)
- Eureka. (n.d.). Novel synthesis route of pranlukast intermediate 4-(4-phenylbutoxy)benzoic acid. Retrieved from [\[Link\]](#)
- TSI Journals. (2013). Synthesis of pranlukast. Retrieved from [\[Link\]](#)
- ChemSrc. (n.d.). 8-[4(4-phenylbutoxy)benzoyl]amino-2-(5-tetrazolyl)-4-oxo-4H-1-benzopyran | 150821-03-7. Retrieved from [\[Link\]](#)
- Patricia, V. (2008). Advances in Green Chemistry for Pharmaceutical Applications. Pharmaceutical Technology. Retrieved from [\[Link\]](#)
- MDPI. (2024). Reshaping Chemical Manufacturing Towards Green Process Intensification: Recent Findings and Perspectives. Retrieved from [\[Link\]](#)

Need Custom Synthesis?

BenchChem offers custom synthesis for rare earth carbides and specific isotopic labeling.

Email: info@benchchem.com or [Request Quote Online](#).

Sources

- [1. Novel synthesis route of pranlukast intermediate 4-\(4-phenylbutoxy\)benzoic acid - Eureka | Patsnap \[eureka.patsnap.com\]](#)

- [2. bocsci.com \[bocsci.com\]](#)
- [3. tsijournals.com \[tsijournals.com\]](#)
- [4. 8-\[4\(4-phenylbutoxy\)benzoyl\]amino-2-\(5-tetrazolyl\)-4-oxo-4H-1-benzopyran CAS#: 150821-03-7 \[m.chemicalbook.com\]](#)
- [5. 8-\[4\(4-phenylbutoxy\)benzoyl\]amino-2-\(5-tetrazolyl\)-4-oxo-4H-1-benzopyran | 150821-03-7 \[chemicalbook.com\]](#)
- [6. arborpharmchem.com \[arborpharmchem.com\]](#)
- [7. researchgate.net \[researchgate.net\]](#)
- [8. JP2007231019A - Process for producing 8-amino-4-oxo-2- \(tetrazol-5-yl\) -4H-1-benzopyran or a salt thereof, and intermediate for production thereof - Google Patents \[patents.google.com\]](#)
- [9. pharmtech.com \[pharmtech.com\]](#)
- [10. mdpi.com \[mdpi.com\]](#)
- [11. data.epo.org \[data.epo.org\]](#)
- To cite this document: BenchChem. [A Comparative Guide to Alternative Intermediates in the Synthesis of Ranlukast]. BenchChem, [2026]. [Online PDF]. Available at: [<https://www.benchchem.com/product/b1268288/docs#a-comparative-guide-to-alternative-intermediates-in-the-synthesis-of-ranlukast>]

Disclaimer & Data Validity:

The information provided in this document is for Research Use Only (RUO) and is strictly not intended for diagnostic or therapeutic procedures. While BenchChem strives to provide accurate protocols, we make no warranties, express or implied, regarding the fitness of this product for every specific experimental setup.

Technical Support: The protocols provided are for reference purposes. Unsure if this reagent suits your experiment?

Need Industrial/Bulk Grade? [Request Custom Synthesis Quote](#)

BenchChem

Our mission is to be the trusted global source of essential and advanced chemicals, empowering scientists and researchers to drive progress in science and industry.

Contact

Address: 3281 E Guasti Rd

Ontario, CA 91761, United States

Phone: (601) 213-4426

Email: info@benchchem.com

[Contact our Ph.D. Support Team for a compatibility check](#)