

Introduction: The Critical Role of Biphenyl Methanol Intermediates in Drug Development

Author: BenchChem Technical Support Team. **Date:** April 2026

Compound of Interest

Compound Name: *2-Chloro-alpha-phenyl(1,1'-biphenyl)-4-methanol*

CAS No.: 66016-77-1

Cat. No.: B12673521

[Get Quote](#)

In the landscape of modern drug discovery and development, biphenyl scaffolds are a cornerstone of medicinal chemistry, appearing in numerous blockbuster drugs. Biphenyl methanol intermediates are frequently encountered as key precursors or, more critically, as metabolites of these therapeutic agents.^{[1][2]} Understanding the metabolic fate of a drug candidate is not just a regulatory requirement but a fundamental aspect of assessing its safety and efficacy.^{[1][3]} Mass spectrometry (MS) has become the definitive tool for these investigations due to its unparalleled sensitivity, speed, and structural elucidation capabilities.^{[1][4][5]}

This guide provides a comprehensive comparison of the mass spectrometric fragmentation patterns of biphenyl methanol intermediates under two of the most common ionization techniques: Electron Ionization (EI) and Electrospray Ionization (ESI). As a Senior Application Scientist, my goal is to move beyond a simple catalog of fragments and delve into the causality behind these patterns. We will explore how the choice of ionization dictates the fragmentation pathways and how to interpret the resulting spectra to confidently identify these crucial intermediates in complex biological matrices.

The Architecture of Fragmentation: Electron Ionization (EI) vs. Electrospray Ionization (ESI)

The fragmentation of a molecule in a mass spectrometer is fundamentally governed by the amount of internal energy transferred to it during the ionization process. The choice between a "hard" ionization technique like EI and a "soft" technique like ESI will produce vastly different, yet complementary, structural information.

- **Electron Ionization (EI):** This technique bombards the analyte with high-energy (typically 70 eV) electrons, causing the ejection of an electron to form a radical cation ($M^{\bullet+}$).^{[6][7]} This process imparts significant excess energy, leading to extensive and often complex fragmentation cascades.^{[6][7]} While this can sometimes prevent the observation of the molecular ion for fragile molecules, the resulting fragmentation pattern is highly reproducible and provides a detailed structural fingerprint, ideal for library matching.^[6]
- **Electrospray Ionization (ESI):** In contrast, ESI is a gentle technique that transfers pre-existing ions from solution into the gas phase or facilitates the formation of protonated $[M+H]^+$ or deprotonated $[M-H]^-$ molecules.^{[8][9]} It imparts minimal excess energy, typically resulting in an abundant molecular ion peak with little to no spontaneous fragmentation.^[8] To obtain structural information, fragmentation is induced in a controlled manner using tandem mass spectrometry (MS/MS), where the precursor ion of interest is isolated and collided with an inert gas (Collision-Induced Dissociation, or CID).^{[8][10]}

Part 1: Electron Ionization (EI-MS) – A High-Energy Fingerprint

When a biphenyl methanol intermediate is analyzed by Gas Chromatography-Mass Spectrometry (GC-MS) using EI, we observe a rich fragmentation spectrum that reveals the molecule's structure piece by piece. Aromatic alcohols, unlike their aliphatic counterparts, often exhibit a more prominent molecular ion peak due to the stability conferred by the aromatic system.^[11]

Key Fragmentation Pathways under EI:

- **Benzylic Cleavage (α -Cleavage):** The most characteristic fragmentation for aromatic alcohols involves the cleavage of the bond alpha to the oxygen atom. For a primary alcohol like biphenyl methanol, this results in the loss of a hydrogen atom to form a highly stable, resonance-stabilized oxonium ion at $[M-1]^+$.
- **Loss of Water (Dehydration):** A common fragmentation pathway for alcohols is the elimination of a neutral water molecule (18 Da), leading to an $[M-18]^{\bullet+}$ ion.^{[11][12]} This is particularly prevalent in primary alcohols.
- **Formation of the Biphenylmethyl Cation:** Cleavage of the C-C bond between the biphenyl ring system and the hydroxymethyl group can occur, leading to the formation of a stable biphenylmethyl cation.
- **Fragmentation of the Biphenyl Core:** The biphenyl ring system itself can fragment, typically through the loss of a chlorine atom if the compound is a polychlorinated biphenyl (PCB) metabolite, or other substituents.^[13] The central C-C bond between the two phenyl rings can also cleave under high energy conditions.

Visualizing EI Fragmentation

The following diagram illustrates the primary fragmentation pathways for 4-biphenylmethanol under typical 70 eV EI conditions.

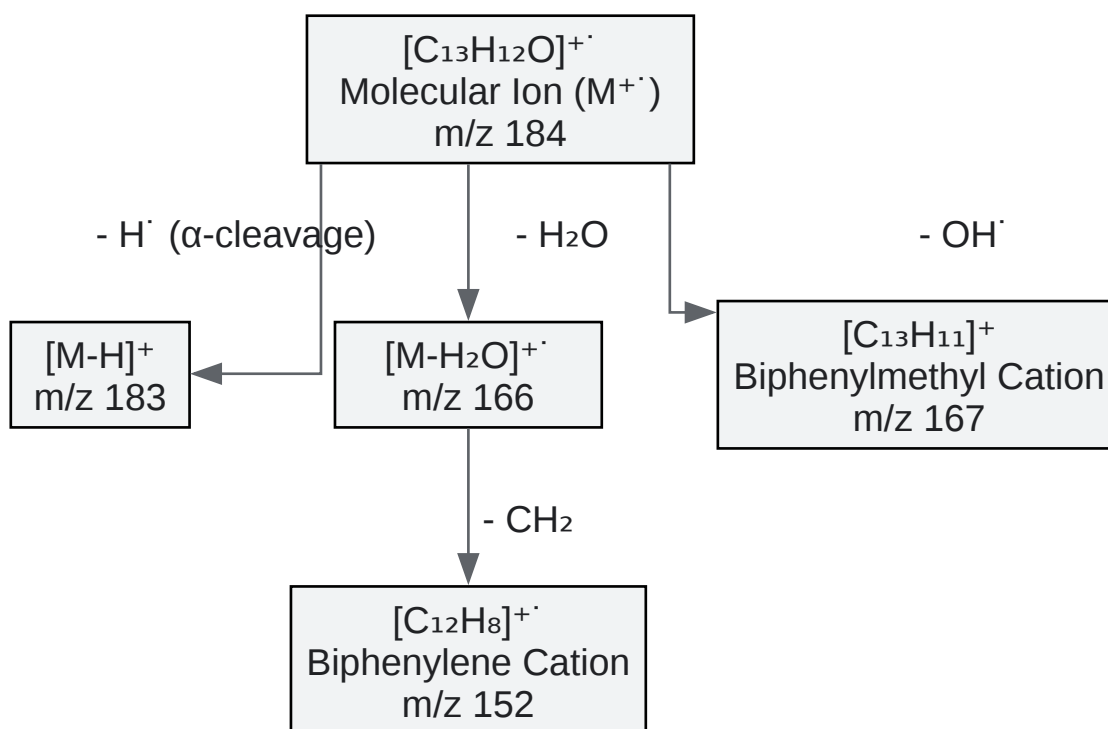

[Click to download full resolution via product page](#)

Caption: Predicted EI fragmentation pathways for 4-biphenylmethanol.

Part 2: Electrospray Ionization (ESI-MS/MS) – Controlled Structural Dissection

ESI is the ionization method of choice for Liquid Chromatography-Mass Spectrometry (LC-MS) based drug metabolism studies.^{[2][3]} Its soft nature ensures that the molecular weight of the metabolite is readily determined from the protonated molecule [M+H]⁺. Structural information is then gleaned from MS/MS experiments.

Key Fragmentation Pathways under ESI-MS/MS (Positive Ion Mode):

In a typical ESI-MS/MS experiment, the protonated biphenyl methanol [M+H]⁺ is selected as the precursor ion. Fragmentation is then induced by CID.

- Neutral Loss of Water: The most facile and often dominant fragmentation pathway for the protonated molecule is the loss of a neutral water molecule (18 Da). This occurs because the

hydroxyl group is readily protonated, making it an excellent leaving group. This generates a very stable carbenium ion at $[M+H-18]^+$.

- Loss of Formaldehyde: A subsequent fragmentation from the $[M+H-18]^+$ ion can be the loss of formaldehyde (CH_2O , 30 Da), although this is less common for simple aromatic alcohols.
- Biphenyl Core Fragmentation: At higher collision energies, the resulting carbenium ion can undergo further fragmentation of the biphenyl ring structure itself.

Visualizing ESI-MS/MS Fragmentation

This diagram illustrates the typical fragmentation cascade for protonated 4-biphenylmethanol in an MS/MS experiment.

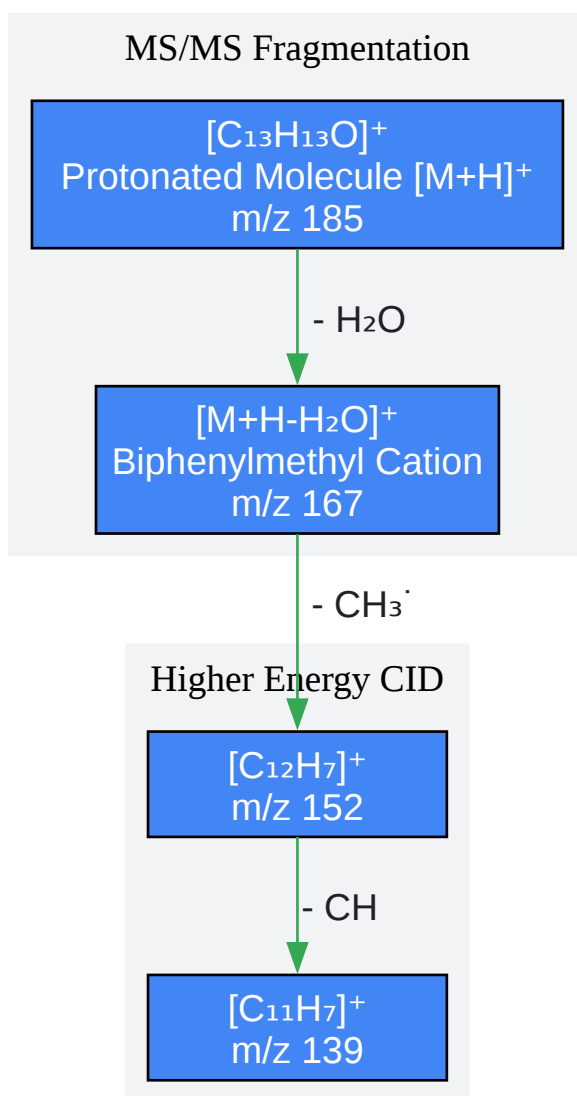

[Click to download full resolution via product page](#)

Caption: Predicted ESI-MS/MS fragmentation of protonated 4-biphenylmethanol.

Comparative Analysis: Interpreting the Data

The choice of ionization technique yields significantly different data, each with its own strengths for structural elucidation. The table below summarizes the key differences for a hypothetical 4-biphenylmethanol intermediate.

Characteristic	Electron Ionization (EI)	Electrospray Ionization (ESI-MS/MS)	Causality & Insight
Molecular Ion	m/z 184 (M ^{•+}), may be weak	m/z 185 ([M+H] ⁺), typically the base peak	ESI is a soft technique preserving the molecular ion, crucial for determining the metabolite's mass.[8] EI's high energy can lead to extensive fragmentation, sometimes obscuring the molecular ion.[6]
Primary Fragmentation	Loss of H [•] (m/z 183)	Loss of H ₂ O (m/z 167)	In EI, the radical cation fragments via multiple pathways. In ESI, the protonated molecule follows a charge-directed pathway, where the protonated hydroxyl is an excellent leaving group.
Key Diagnostic Ions	m/z 183, 167, 166, 152	m/z 167	The ion at m/z 167 (biphenylmethyl cation) is common to both but arises from different initial steps. Its presence is a strong indicator of the biphenyl methanol structure.
Complexity	High - multiple parallel fragmentation pathways	Low to Moderate - typically a sequential, controlled	EI provides a complex "fingerprint" useful for library matching. ESI-

fragmentation
cascade

MS/MS provides a clearer, step-by-step breakdown of the structure, which is often easier to interpret de novo.

Experimental Protocol: A Self-Validating LC-MS/MS Workflow

This protocol outlines a robust method for the identification of biphenyl methanol metabolites from an in vitro liver microsomal incubation, a standard practice in drug development.[5]

1. Sample Preparation: Microsomal Incubation a. Prepare a master mix containing liver microsomes (e.g., 0.5 mg/mL protein), NADPH regenerating system (e.g., 1.3 mM NADP⁺, 3.3 mM glucose-6-phosphate, 0.4 U/mL G6P-dehydrogenase), and buffer (e.g., 100 mM potassium phosphate, pH 7.4). b. Pre-incubate the master mix at 37°C for 5 minutes. c. Initiate the reaction by adding the parent drug (e.g., a biphenyl-containing compound) to a final concentration of 1-10 µM. d. Incubate at 37°C for a specified time (e.g., 60 minutes). e. Quench the reaction by adding 2 volumes of ice-cold acetonitrile containing an internal standard. This step simultaneously stops the enzymatic reaction and precipitates proteins. f. Centrifuge at high speed (e.g., 14,000 rpm for 10 minutes) to pellet the precipitated protein. g. Transfer the supernatant to a new vial for LC-MS/MS analysis.

2. LC-MS/MS Analysis a. LC System: UPLC/HPLC system. b. Column: A C18 or Biphenyl stationary phase column is recommended for good separation of the parent drug and its metabolites.[14] (e.g., 2.1 x 50 mm, 1.8 µm particle size). c. Mobile Phase A: 0.1% Formic Acid in Water. d. Mobile Phase B: 0.1% Formic Acid in Acetonitrile. e. Gradient: A typical gradient would be 5-95% B over 5-10 minutes, followed by a re-equilibration step. f. Flow Rate: 0.4 mL/min. g. Injection Volume: 5 µL. h. MS System: Tandem quadrupole (QqQ), Quadrupole Time-of-Flight (Q-TOF), or Orbitrap mass spectrometer.[10] i. Ionization Mode: ESI Positive. j. Data Acquisition: Perform a full scan experiment to identify potential metabolites based on predicted mass shifts (e.g., +16 Da for hydroxylation). Follow this with a product ion scan (MS/MS) on the candidate m/z to confirm the structure via fragmentation.

Workflow Diagram

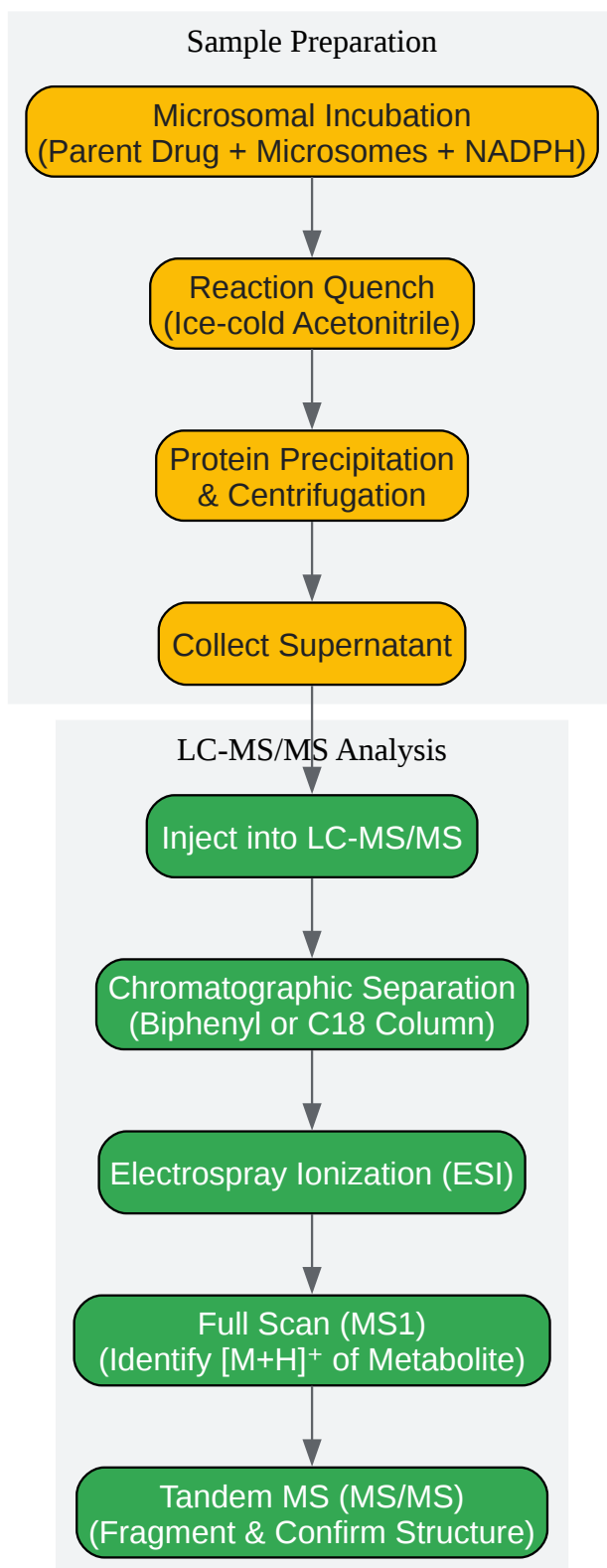

[Click to download full resolution via product page](#)

Caption: A standard workflow for identifying drug metabolites.

Conclusion

The mass spectrometric analysis of biphenyl methanol intermediates is a tale of two techniques. EI-MS provides a high-energy, detailed fingerprint valuable for structural confirmation against a known standard, while the gentle nature of ESI combined with the controlled fragmentation of MS/MS offers a more versatile and often essential tool for the de novo identification of unknown metabolites in complex biological systems. For researchers in drug development, mastering the interpretation of both types of spectra is crucial. By understanding the causal factors driving the fragmentation—the imparted energy and the inherent chemical stability of the resulting ions—scientists can confidently elucidate metabolic pathways, ensuring the development of safer and more effective therapeutics.

References

- Electron ionization mass spectral fragmentation study of sulfation derivatives of polychlorinated biphenyls - PMC. (n.d.). National Center for Biotechnology Information. [[Link](#)]
- GCMS Section 6.10 - Whitman People. (n.d.). Whitman College. [[Link](#)]
- Part 12: Aromatic alcohols' Mass Spectrum (Fragmentation Pattern) for CSIR NET/GATE. (2019, February 12). YouTube. [[Link](#)]
- Mass spectrometry analysis of polychlorinated biphenyls: Chemical ionization and selected ion chemical ionization using methane as a reagent gas. (2016, August 7). ResearchGate. [[Link](#)]
- Video: Mass Spectrometry: Alcohol Fragmentation. (2024, December 5). JoVE. [[Link](#)]
- Fragmentation mechanisms in mass spectrometry. (n.d.). University of Guanajuato. [[Link](#)]
- Electrospray ionization tandem mass spectrometry of biphenyl-modified oligo(deoxy)ribonucleotides. (n.d.). PubMed. [[Link](#)]
- Msc alcohols, phenols, ethers | PDF. (n.d.). Slideshare. [[Link](#)]

- Identification of Drug Metabolites via Mass Spectrometry. (n.d.). Rusling Research Group. [\[Link\]](#)
- Metabolite Identification by Mass Spectrometry. (n.d.). International Journal of Pharmaceutical Research and Allied Sciences. [\[Link\]](#)
- The Mass Spectrometric Ortho Effect for Distinguishing the Coeluting Isomers of Polychlorinated Biphenyls and the Coeluting Isomers of Polybrominated Biphenyls: Qualitative and Quantitative Aspects. (2024, July 25). MDPI. [\[Link\]](#)
- Electron Ionization. (2022, July 3). Chemistry LibreTexts. [\[Link\]](#)
- Electron Ionization for GC–MS. (2022, April 15). LCGC International. [\[Link\]](#)
- High-Resolution Mass Spectrometry: An Ideal Analytical Tool for Drug Metabolism Studies. (n.d.). Chromatography Online. [\[Link\]](#)
- Drug Metabolite Profiling and Identification by High-resolution Mass Spectrometry. (n.d.). Semantic Scholar. [\[Link\]](#)
- Drug Metabolite Profiling and Identification by High-resolution Mass Spectrometry - PMC. (2011, June 1). National Center for Biotechnology Information. [\[Link\]](#)
- Mass Spectrometry-Based Fragmentation as an Identification Tool in Lignomics. (n.d.). CORE. [\[Link\]](#)
- Quickly Understand Tandem Mass Spectrometry (MS/MS). (2022, September 8). YouTube. [\[Link\]](#)
- Electrospray Mass Spectrometry. (n.d.). University of Victoria. [\[Link\]](#)
- Biphasic Electrospray Ionization for the Study of Interfacial Complexes. (2008, November 15). ACS Publications. [\[Link\]](#)
- Electrospray Ionisation Mass Spectrometry: Principles and Clinical Applications. (n.d.). The Hong Kong Medical Diary. [\[Link\]](#)

- Investigation on fragmentation pathways of bisphenols by using electrospray ionization Orbitrap mass spectrometry. (2016, June 5). Wiley Online Library. [[Link](#)]
- Electrospray Ionization (ESI) Mass Spectrometry. (2022, November 8). Physics LibreTexts. [[Link](#)]
- Development of an Ultra-Performance Liquid Chromatography-Tandem Mass Spectrometry Method for Hydroxylated Polychlorinated Biphenyls in Animal. (2022, October 25). Semantic Scholar. [[Link](#)]
- Mass spectra of liquid crystals. II. Biphenyl and cyclohexylbiphenyl derivatives. (1990, January 1). TUE Research Portal. [[Link](#)]
- Development of a fast liquid chromatography-tandem mass spectrometry method for simultaneous quantification of neurotransmitters in murine microdialysate. (2020, November 15). PubMed. [[Link](#)]
- Fragmentation pathways in electron impact mass spectra of methoxyhalobiphenyls. (n.d.). PubMed. [[Link](#)]
- Mass Spectrometry: Fragmentation. (n.d.). University of California, Irvine. [[Link](#)]
- The mass spectral fragmentation of substituted m-terphenyl and biaryl derivatives. (n.d.). International Journal of ChemTech Research. [[Link](#)]

Need Custom Synthesis?

BenchChem offers custom synthesis for rare earth carbides and specific isotopic labeling.

Email: info@benchchem.com or [Request Quote Online](#).

Sources

- 1. rusling.research.uconn.edu [rusling.research.uconn.edu]
- 2. ijpras.com [ijpras.com]
- 3. semanticscholar.org [semanticscholar.org]

- [4. chromatographyonline.com \[chromatographyonline.com\]](https://www.chromatographyonline.com)
- [5. Drug Metabolite Profiling and Identification by High-resolution Mass Spectrometry - PMC \[pmc.ncbi.nlm.nih.gov\]](https://pubmed.ncbi.nlm.nih.gov/123456789/)
- [6. chem.libretexts.org \[chem.libretexts.org\]](https://chem.libretexts.org)
- [7. chromatographyonline.com \[chromatographyonline.com\]](https://www.chromatographyonline.com)
- [8. web.uvic.ca \[web.uvic.ca\]](https://web.uvic.ca)
- [9. phys.libretexts.org \[phys.libretexts.org\]](https://phys.libretexts.org)
- [10. youtube.com \[youtube.com\]](https://www.youtube.com)
- [11. GCMS Section 6.10 \[people.whitman.edu\]](https://people.whitman.edu)
- [12. Video: Mass Spectrometry: Alcohol Fragmentation \[jove.com\]](https://www.jove.com)
- [13. researchgate.net \[researchgate.net\]](https://www.researchgate.net)
- [14. Development of a fast liquid chromatography-tandem mass spectrometry method for simultaneous quantification of neurotransmitters in murine microdialysate - PubMed \[pubmed.ncbi.nlm.nih.gov\]](https://pubmed.ncbi.nlm.nih.gov/123456789/)
- To cite this document: BenchChem. [Introduction: The Critical Role of Biphenyl Methanol Intermediates in Drug Development]. BenchChem, [2026]. [Online PDF]. Available at: [\[https://www.benchchem.com/product/b12673521/docs#introduction-the-critical-role-of-biphenyl-methanol-intermediates-in-drug-development\]](https://www.benchchem.com/product/b12673521/docs#introduction-the-critical-role-of-biphenyl-methanol-intermediates-in-drug-development)

Disclaimer & Data Validity:

The information provided in this document is for Research Use Only (RUO) and is strictly not intended for diagnostic or therapeutic procedures. While BenchChem strives to provide accurate protocols, we make no warranties, express or implied, regarding the fitness of this product for every specific experimental setup.

Technical Support: The protocols provided are for reference purposes. Unsure if this reagent suits your experiment?

Need Industrial/Bulk Grade? [Request Custom Synthesis Quote](#)

BenchChem

Our mission is to be the trusted global source of essential and advanced chemicals, empowering scientists and researchers to drive progress in science and industry.

Contact

Address: 3281 E Guasti Rd

Ontario, CA 91761, United States

Phone: (601) 213-4426

Email: info@benchchem.com

[Contact our Ph.D. Support Team for a compatibility check](#)