

Relative Reactivity of Butylbiphenyl Isomers in Further Functionalization

Author: BenchChem Technical Support Team. **Date:** April 2026

Compound of Interest

Compound Name: *3-Butylbiphenyl*

CAS No.: *81782-75-4*

Cat. No.: *B12672722*

[Get Quote](#)

Executive Summary

In medicinal chemistry and materials science, the biphenyl scaffold is a privileged structure. The introduction of a butyl group at the 4-position modulates lipophilicity and metabolic stability. However, the specific isomer—

-butyl (linear) versus

-butyl (branched)—drastically alters the molecule's reactivity profile in subsequent functionalization steps.

This guide demonstrates that while both isomers share similar electronic activation patterns, their steric demands and benzylic C-H bond strengths dictate divergent synthetic outcomes. Specifically, the tert-butyl group acts as a steric shield and a metabolic blocker, whereas the n-butyl group offers accessible sites for regioselective substitution and oxidative functionalization.

Structural & Electronic Analysis

Before designing a synthesis, one must understand the substrate's electronic landscape. Both isomers feature an electron-rich Ring A (bearing the alkyl group) and a moderately activated

Ring B.

Feature	4- -Butylbiphenyl	4- -Butylbiphenyl
Electronic Effect	Inductive (+I) activation of Ring A.	Inductive (+I) activation of Ring A (stronger +I than -Bu).
Steric Profile	Minimal steric bulk at -carbon. Flexible chain.	Massive steric bulk at -carbon. Rigid, spherical volume.
Benzylic C-H	Secondary () C-H bonds. High reactivity.	Quaternary () carbon. No benzylic hydrogens.
Directing Effect	Ortho/Para directing (relative to butyl).	Ortho/Para directing (relative to butyl).

Graphviz Analysis: Steric vs. Electronic Logic

The following diagram illustrates the logical decision tree for predicting regioselectivity based on the isomer type.

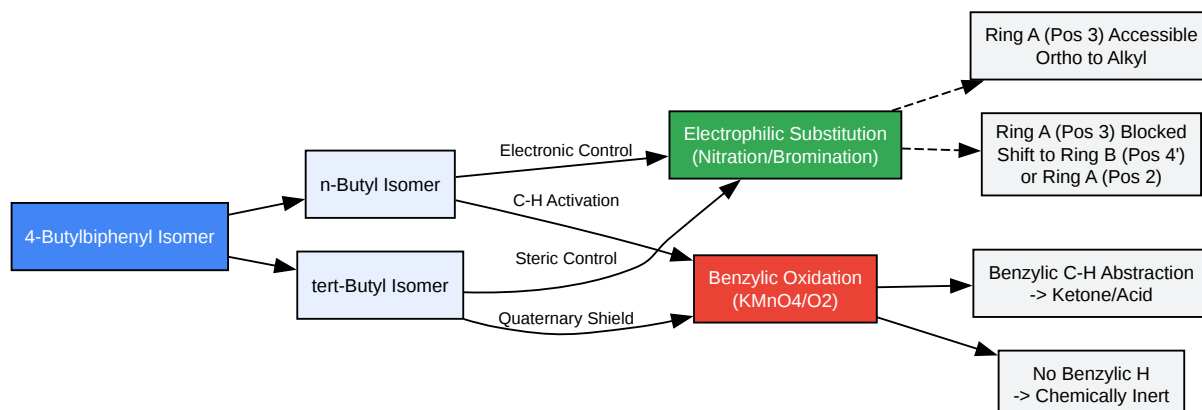

[Click to download full resolution via product page](#)

Caption: Decision tree showing how steric bulk and benzylic hydrogen presence dictate reaction pathways for butylbiphenyl isomers.

Comparative Reactivity Profiles

A. Electrophilic Aromatic Substitution (Nitration)

The most critical difference lies in regioselectivity.

- Electronic Rule: Alkyl groups are stronger activators than phenyl groups. Therefore, substitution should occur on Ring A (the ring with the butyl group).
- Steric Exception: The tert-butyl group blocks the positions adjacent to it (positions 3 and 5).

Substrate	Major Product Region	Mechanistic Rationale
4- -Butylbiphenyl	Ring A (Position 3)	The -butyl group activates the ortho position (3). Steric hindrance is low, allowing the electrophile to access this electronically favored site.
4- -Butylbiphenyl	Ring B (Position 4') or Ring A (Position 2)	The ortho positions (3,5) are sterically occluded by the bulky -butyl group. The reaction shifts to the less hindered para-position of Ring B (4') or the ortho-position relative to the phenyl ring (2).

Experimental Insight: In nitration using

, 4-

-butylbiphenyl yields a mixture favoring the 3-nitro isomer. In contrast, 4-

-butylbiphenyl often yields significant amounts of 4'-nitro-4-tert-butylbiphenyl (substitution on the distal ring) because the electronic advantage of Ring A is negated by the kinetic barrier of steric hindrance.

B. Oxidation (Benzylic Functionalization)

This is a binary "Go/No-Go" difference essential for drug metabolism (DMPK) studies.

- 4-

-Butylbiphenyl: Highly reactive toward oxidants (KMnO

, CrO

). The benzylic methylene group is a "soft spot" for metabolic degradation (CYP450) or

chemical oxidation to 4-biphenylcarboxylic acid (via chain cleavage) or 1-(4-biphenyl)-1-butanone.

- 4-

-Butylbiphenyl: The quaternary carbon prevents benzylic oxidation. The alkyl group remains intact even under harsh oxidative conditions (e.g., refluxing KMnO

). This makes the tert-butyl group an excellent "metabolic blocker" to extend the half-life of a drug candidate.

Detailed Experimental Protocols

Protocol 1: Regioselective Nitration (General Procedure)

This protocol allows you to observe the regiochemical difference between the isomers.

Reagents:

- Substrate (1.0 equiv)

- Conc.

(1.1 equiv)

- Conc.

(Catalytic volume)

- Acetic Anhydride (

) as solvent (moderates reactivity)

Workflow:

- Dissolution: Dissolve 10 mmol of the butylbiphenyl isomer in 15 mL of acetic anhydride at 0°C.
- Activation: Prepare a nitrating mixture of

(11 mmol) and 2 drops of

in 5 mL cold acetic anhydride.

- Addition: Add the nitrating mixture dropwise to the substrate solution over 20 minutes, maintaining temperature $<10^{\circ}\text{C}$.
 - Note: For

-butyl, the solution typically darkens quickly due to rapid complexation at the unhindered Ring A.
 - Note: For

-butyl, the reaction may be slower; allow to warm to room temperature if no color change occurs after 1 hour.
- Quench: Pour mixture into 100 mL ice-water.
- Isolation: Extract with Ethyl Acetate (3 x 30 mL). Wash with saturated

and brine.^[1] Dry over

.
- Analysis: Analyze crude via

H-NMR.
 - -Butyl: Look for loss of symmetry in Ring A signals and a new singlet/doublet corresponding to the proton at position 2 (adjacent to nitro).
 - -Butyl: Look for symmetry retention in Ring A (AA'BB' system) and substitution patterns on Ring B (AA'BB'

AA'XX' if para-substituted).

Protocol 2: Chemical Stability Test (KMnO₄ Oxidation)

Purpose: To differentiate the oxidative stability of the alkyl chain.

- Setup: In a 50 mL round-bottom flask, suspend 2 mmol of substrate in 10 mL

-BuOH/H

O (1:1).
- Oxidant: Add 6 mmol

and 1 mmol

.
- Reaction: Reflux for 3 hours.
- Workup: Filter hot through Celite to remove

. Acidify filtrate with 1M HCl to pH 2.
- Result:
 - -Butyl: Precipitate forms upon acidification (4-biphenylcarboxylic acid).
 - -Butyl: No precipitate (or recovery of starting material upon extraction), confirming stability.

Performance Data Summary

The following table summarizes expected outcomes based on standard electrophilic aromatic substitution (EAS) and oxidation conditions.

Reaction Type	Parameter	4- -Butylbiphenyl	4- -Butylbiphenyl
Nitration ()	Primary Site	Ring A (Pos 3)	Ring B (Pos 4') or Ring A (Pos 2)
Yield	High (>85%)	Moderate (60-75%) due to steric drag	
Selectivity	High (Ortho to alkyl)	Low (Mixture of isomers)	
Bromination ()	Primary Site	Ring A (Pos 3)	Ring B (Pos 4')
Oxidation ()	Product	4-Biphenylcarboxylic acid	Recovered Starting Material
Metabolic Stability	CYP450	Low (High clearance)	High (Blocked site)

References

- Wine, T. P. J. (2021). The Regiochemistry and Relative Reaction Rates of Methylbiphenyl Isomers in Electrophilic Aromatic Substitution. Seattle Pacific University Honors Projects. [\[Link\]](#)
 - Validates the preference for nitration on the alkyl
- Provides relative rate data for alkylbenzenes (Toluene vs t-Butylbenzene)
- Master Organic Chemistry. (2017). Oxidation of Aromatic Alkanes with KMnO4. [\[Link\]](#)
 - Authoritative source for the mechanism of benzylic oxidation and the stability of qu
- PubChem. (2025). 4-tert-Butylbiphenyl Compound Summary. [\[Link\]](#)
 - Source for physical property data and structural confirm

Need Custom Synthesis?

BenchChem offers custom synthesis for rare earth carbides and specific isotopic labeling.

Email: info@benchchem.com or [Request Quote Online](#).

Sources

- 1. pdf.benchchem.com [pdf.benchchem.com]
- To cite this document: BenchChem. [Relative Reactivity of Butylbiphenyl Isomers in Further Functionalization]. BenchChem, [2026]. [Online PDF]. Available at: [<https://www.benchchem.com/product/b12672722/docs#relative-reactivity-of-butylbiphenyl-isomers-in-further-functionalization>]

Disclaimer & Data Validity:

The information provided in this document is for Research Use Only (RUO) and is strictly not intended for diagnostic or therapeutic procedures. While BenchChem strives to provide accurate protocols, we make no warranties, express or implied, regarding the fitness of this product for every specific experimental setup.

Technical Support: The protocols provided are for reference purposes. Unsure if this reagent suits your experiment?

Need Industrial/Bulk Grade? [Request Custom Synthesis Quote](#)

BenchChem

Our mission is to be the trusted global source of essential and advanced chemicals, empowering scientists and researchers to drive progress in science and industry.

Contact

Address: 3281 E Guasti Rd

Ontario, CA 91761, United States

Phone: (601) 213-4426

Email: info@benchchem.com

Contact our Ph.D. Support Team for a compatibility check