

Technical Support Center: Navigating the Stability of the Isoxazole Ring

Author: BenchChem Technical Support Team. **Date:** May 2026

Compound of Interest

Compound Name: Ethyl 4-methyl-5-oxo-2,5-dihydroisoxazole-3-carboxylate

CAS No.: 84280-59-1

Cat. No.: B1267927

[Get Quote](#)

As a Senior Application Scientist, I've frequently fielded questions from researchers navigating the complexities of the isoxazole ring. This five-membered heterocycle is a cornerstone in medicinal chemistry and synthetic organic chemistry, valued for both its stability as a bioisosteric scaffold and its latent reactivity, which can be harnessed to create diverse molecular architectures.^{[1][2]} However, its stability is not absolute. The inherent weakness of the N-O bond makes the ring susceptible to cleavage under a variety of conditions, a feature that can be either a powerful synthetic tool or a frustrating experimental pitfall.^{[1][3][4]}

This guide is designed to provide you with direct, actionable answers to the common stability challenges encountered during synthesis, workup, and purification. We will explore the causality behind the ring's behavior under different stressors and provide validated protocols to help you control your experimental outcomes.

Frequently Asked Questions (FAQs): Troubleshooting Isoxazole Stability Section 1: Stability in Acidic & Basic Media

Question: My isoxazole-containing compound is degrading during an acidic workup or purification. What is happening and how can I prevent it?

Answer: While generally more stable under acidic than basic conditions, the isoxazole ring can undergo acid-catalyzed hydrolysis, particularly at low pH values (<3.5) and elevated temperatures.[5] The mechanism involves protonation of the ring nitrogen, which activates the ring for nucleophilic attack by water, leading to N-O bond cleavage.

- Causality: The protonation of the nitrogen atom makes the C3 and C5 positions more electrophilic, facilitating ring opening. The specific degradation products can vary depending on the substitution pattern of your isoxazole. For example, N-(3,4-dimethyl-5-isoxazolyl)-4-amino-1,2-naphthoquinone was found to degrade in acidic conditions to 2-hydroxy-1,4-naphthoquinone and 2-butanone, among other products.[5] Studies on sulfonamide isoxazole derivatives in concentrated sulfuric acid also highlight the potential for hydrolysis under strongly acidic conditions.[6]
- Troubleshooting & Prevention:
 - Use Milder Acids: If possible, switch to weaker acids for pH adjustment (e.g., saturated ammonium chloride, 10% citric acid solution) instead of strong mineral acids like HCl or H₂SO₄.
 - Maintain Low Temperatures: Perform all acidic washes and extractions at low temperatures (0-5 °C) to decrease the rate of hydrolysis.
 - Minimize Contact Time: Do not let your compound sit in acidic media for extended periods. Work through the extraction and washing steps efficiently.
 - Alternative Purification: Consider non-acidic purification methods, such as column chromatography with a neutral solvent system or recrystallization.

Question: My reaction yield is dramatically lower after a basic workup (e.g., NaOH, K₂CO₃ wash). Why is the isoxazole ring so sensitive to bases?

Answer: Base-mediated ring opening is a well-documented liability for many isoxazoles.[3][7] The sensitivity is highly dependent on the substitution pattern, pH, and temperature. The mechanism often involves the deprotonation of a proton on a carbon adjacent to the ring

nitrogen (especially at the C3 position if unsubstituted), which initiates the cleavage of the weak N-O bond.[1]

- **Causality & Evidence:** The anti-inflammatory drug Leflunomide provides an excellent case study. Its isoxazole ring is stable at acidic and neutral pH at room temperature. However, at a basic pH of 10.0, it degrades with a half-life of about 6.0 hours at 25°C. This degradation is significantly accelerated at physiological temperature (37°C), where the half-life at pH 7.4 is 7.4 hours, and at pH 10.0, it drops to just 1.2 hours.[8] This demonstrates that even moderately basic conditions can be detrimental, especially with heating.
- **Troubleshooting & Prevention:**
 - **Avoid Strong Bases:** Whenever possible, use milder inorganic bases like sodium bicarbonate (NaHCO₃) for washes instead of hydroxides (NaOH, KOH) or carbonates (K₂CO₃, Cs₂CO₃).
 - **Temperature Control:** As demonstrated by the Leflunomide data, keeping the temperature low during a basic workup is critical. Perform washes with chilled, dilute basic solutions.
 - **Structural Considerations:** 3-unsubstituted isoxazoles are particularly prone to base-mediated cleavage.[1] If you are designing a synthesis, consider if a substituted isoxazole (e.g., 3,5-disubstituted) could be used, as they tend to be more stable.[9]
 - **Biphasic Conditions:** Performing the reaction or workup in a biphasic system can sometimes limit the exposure of the organic-soluble compound to the aqueous base, mitigating degradation.

This table summarizes the degradation half-life ($t_{1/2}$) of the isoxazole ring in the drug Leflunomide, illustrating the combined impact of pH and temperature.[8]

Temperature (°C)	pH 4.0 (Acidic)	pH 7.4 (Neutral)	pH 10.0 (Basic)
25°C	Stable	Stable	~ 6.0 hours
37°C	Stable	~ 7.4 hours	~ 1.2 hours

This diagram illustrates a plausible mechanism for the ring opening of a 3-unsubstituted isoxazole under basic conditions.

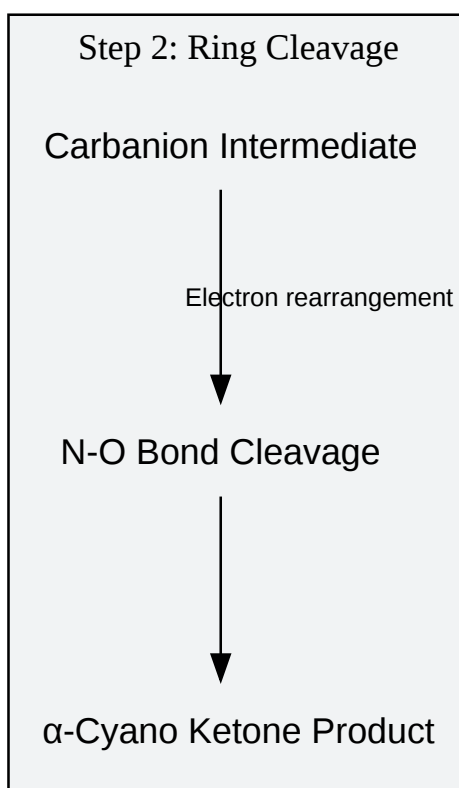
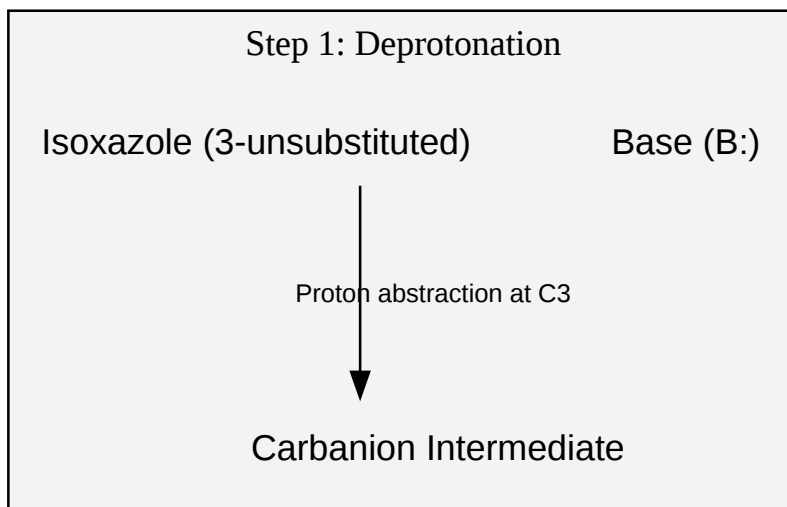

[Click to download full resolution via product page](#)

Caption: Mechanism of base-catalyzed isoxazole ring cleavage.

Section 2: Stability Under Reductive Conditions

Question: I tried to reduce a nitro group on my molecule using catalytic hydrogenation ($H_2/Pd-C$), but my isoxazole ring was cleaved. Why did this happen and what are my alternatives?

Answer: This is a classic and common challenge. The N-O bond of the isoxazole ring is highly susceptible to reductive cleavage by catalytic hydrogenation.^{[1][3][9]} This reaction is so efficient that it is often used intentionally as a synthetic strategy to unmask a β -amino enone or 1,3-dicarbonyl equivalent.^{[1][10]}

- Causality: The palladium (or other metal) catalyst readily facilitates the hydrogenolysis of the weak N-O single bond, leading to ring scission. This process is generally faster than the reduction of many other functional groups, making selectivity a significant issue.
- Troubleshooting & Alternatives:
 - Avoid Catalytic Hydrogenation: If the isoxazole must be preserved, catalytic hydrogenation is not a suitable method for reducing other functional groups.
 - Alternative Reducing Agents for Nitro Groups:
 - Metal/Acid Systems: Consider using metals in acidic media, such as iron powder in acetic acid (Fe/AcOH) or tin(II) chloride ($SnCl_2$). These conditions are often mild enough to preserve the isoxazole ring.
 - Transfer Hydrogenation: Reagents like ammonium formate or cyclohexene with Pd/C can sometimes offer better selectivity, but require careful optimization.
 - Protecting Group Strategy: In some cases, the isoxazole can be used as a "masked" functional group. Carry it through your synthesis and then perform the reductive cleavage at a later stage when the ring opening is desired.

Question: What products should I expect when treating an isoxazole with a strong hydride reducing agent like Lithium Aluminum Hydride ($LiAlH_4$)?

Answer: Treatment of isoxazoles with strong reducing agents like LiAlH_4 does not typically yield the same β -amino enones seen with catalytic hydrogenation. Instead, the reaction proceeds further to give a variety of reduced products.

- **Causality & Expected Products:** LiAlH_4 reduction of alkyl-substituted isoxazoles has been shown to produce complex mixtures. The major products are often β -hydroxyethylaziridines, along with 1,3-amino alcohols and other reduced aziridine derivatives.[11][12][13] The exact product distribution can be dependent on the substitution pattern of the isoxazole and the reaction conditions (e.g., solvent, temperature).[11]
- **Experimental Considerations:**
 - **Product Complexity:** Be prepared for a mixture of products that may be difficult to separate. Careful analysis by GC-MS or LC-MS is crucial.
 - **Safety:** LiAlH_4 reacts violently with water. All glassware must be oven-dried, and the reaction must be run under a strict inert atmosphere (Nitrogen or Argon) using anhydrous solvents.[14]
 - **Inverse Addition:** For some substrates, inverse addition (adding the LiAlH_4 solution to the isoxazole solution) can sometimes improve selectivity by ensuring the hydride is never in large excess.[14]

This diagram shows the divergent outcomes of reducing an isoxazole with different reagents.

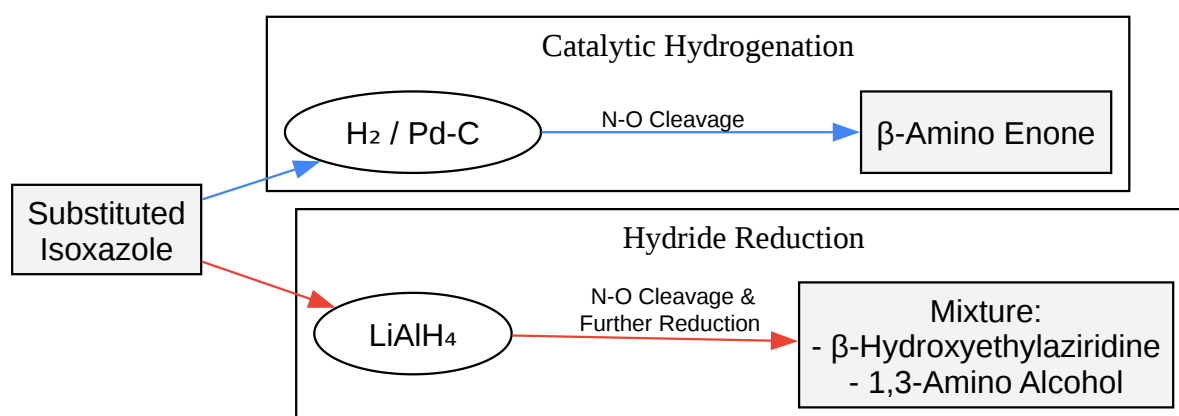

[Click to download full resolution via product page](#)

Caption: Different products from catalytic vs. hydride reduction.

Section 3: Thermal & Photochemical Stability

Question: I am running a reaction at high temperatures and observing the formation of an unexpected isomer. Could the isoxazole ring be rearranging?

Answer: Yes, thermal rearrangement is a known property of isoxazoles. At elevated temperatures, the isoxazole ring can isomerize.^{[15][16]} This process often proceeds through high-energy intermediates like azirines, which can then rearrange to form other heterocycles or lead to fragmentation.^{[15][17]}

- Causality: The thermal energy overcomes the activation barrier for the cleavage of the weak N-O bond, initiating a cascade of rearrangements. The specific outcome depends on the isoxazole's substituents and the precise conditions. In some cases, rearrangement to a more stable oxazole isomer can occur.^[17]
- Troubleshooting:
 - Lower Reaction Temperature: The most straightforward solution is to find alternative conditions that allow the reaction to proceed at a lower temperature.
 - Microwave Synthesis: Microwave-assisted synthesis can sometimes promote desired reactions at lower bulk temperatures over shorter time frames, potentially minimizing thermal rearrangement byproducts.^[18]
 - Catalyst Screening: Investigate different catalysts that may have higher activity, allowing for a reduction in reaction temperature.

Question: My isoxazole-containing compound seems to degrade when left on the benchtop exposed to light. Is this expected?

Answer: Yes, many isoxazole derivatives are sensitive to ultraviolet (UV) light. The N-O bond is photolabile and can cleave upon UV irradiation, leading to a characteristic rearrangement.^{[3][19]}

- Causality & Mechanism: Photolysis of an isoxazole typically causes the N-O bond to break, forming a transient azirine intermediate. This highly strained intermediate can then rearrange to form a more stable oxazole.^{[1][4][19]} This photoreactivity is so reliable that it is now being harnessed for advanced applications like photo-crosslinking in chemoproteomic studies.^{[20][21][22]}
- Prevention:
 - Protect from Light: Store isoxazole-containing compounds in amber vials or wrap containers in aluminum foil.
 - Minimize Exposure: During reactions and workups, minimize exposure to direct sunlight or strong laboratory lighting.
 - Column Chromatography: When running column chromatography, shield the column from light, especially if the separation is lengthy.

This diagram illustrates the generally accepted pathway for the photochemical rearrangement of an isoxazole to an oxazole.

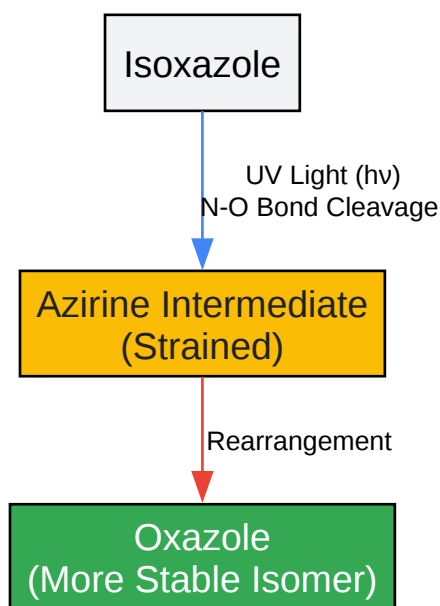

[Click to download full resolution via product page](#)

Caption: The photochemical pathway from isoxazole to oxazole.

Experimental Protocols

Protocol 1: General Procedure for Testing Isoxazole Stability in pH Gradients

This protocol is adapted from methodologies used to study the stability of pharmaceutical compounds like Leflunomide.[8]

- **Prepare Buffer Solutions:** Prepare aqueous buffer solutions at your desired pH values (e.g., pH 4.0, pH 7.4, pH 10.0).
- **Prepare Stock Solution:** Create a concentrated stock solution of your isoxazole compound in a suitable organic solvent (e.g., Methanol, Acetonitrile).
- **Initiate Incubation:** In separate vials for each pH and temperature condition, add a small aliquot of the stock solution to the buffer to achieve a final concentration suitable for analysis (e.g., 2-10 μM).
- **Incubate:** Place the vials in a temperature-controlled environment (e.g., a 25°C water bath and a 37°C water bath).
- **Time-Point Sampling:** At regular intervals (e.g., $t=0$, 1h, 2h, 4h, 8h, 24h), withdraw an aliquot from each vial.
- **Quench Reaction:** Immediately quench the degradation by adding the aliquot to a larger volume of cold acetonitrile containing an internal standard. This will precipitate salts and stop the reaction.
- **Analyze:** Analyze the samples by LC-MS or HPLC to quantify the disappearance of the parent compound over time.
- **Determine Half-Life:** Plot the concentration of the parent compound versus time for each condition to determine the rate of degradation and the half-life ($t_{1/2}$).

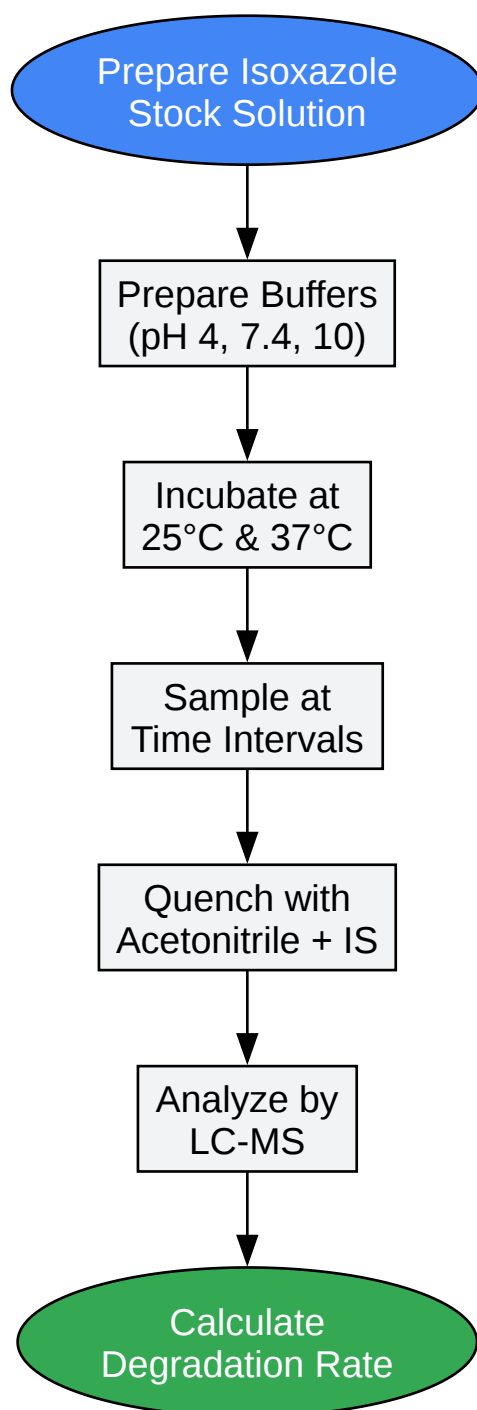

[Click to download full resolution via product page](#)

Caption: Workflow for assessing isoxazole stability across pH.

References

- Reductive ring opening of isoxazoles with Mo(CO)₆ and water. Journal of the Chemical Society, Chemical Communications (RSC Publishing).

- Reductive ring cleavage of 3,5-dimethylisoxazole in irradiation in the presence of triethylamine. Journal of the Chemical Society, Chemical Communications (RSC Publishing).
- Copper-Catalyzed Reductive Ring-Cleavage of Isoxazoles: Synthesis of Fluoroalkylated Enaminones and Application for the Preparation of Celecoxib, Deracoxib, and Mavacoxib. The Journal of Organic Chemistry (ACS Publications). Available at: [\[Link\]](#)
- Reduction of Some Alkylisoxazoles with Lithium Aluminum Hydride. Canadian Journal of Chemistry.
- Copper-Catalyzed Reductive Ring-Cleavage of Isoxazoles: Synthesis of Fluoroalkylated Enaminones and Application for the Preparation of Celecoxib, Deracoxib, and Mavacoxib. The Journal of Organic Chemistry (ACS Publications).
- Isoxazole. Wikipedia. Available at: [\[Link\]](#)
- Studies in isoxazole chemistry. II. Isoxazoles from the Δ^2 -isoxazolin-5-ols and their acetates. Canadian Journal of Chemistry.
- Reductive Ring Opening of Isoxazoles with $M O (C Q) \sim$ and Water. RSC Publishing.
- Thermal isomerization of the isoxazole ring and rearrangement processes in the mass spectra of 3-aryl-5-methylisoxazole-4-carboxylic acids. ScienceGate. Available at: [\[Link\]](#)
- Reduction of Some Alkylisoxazoles with Lithium Aluminum Hydride. Ingenta Connect. Available at: [\[Link\]](#)
- Isoxazole synthesis. Organic Chemistry Portal. Available at: [\[Link\]](#)
- pH and temperature stability of the isoxazole ring in leflunomide. ResearchGate. Available at: [\[Link\]](#)
- Synthetic reactions using isoxazole compounds. Nagoya University Institutional Repository. Available at: [\[Link\]](#)
- Isoxazoles. VI: Aspects of the chemical stability of a new naphthoquinone-amine in acidic aqueous solution. PubMed. Available at: [\[Link\]](#)
- Reduction of Some Alkylisoxazoles with Lithium Aluminum Hydride. ResearchGate. Available at: [\[Link\]](#)

- Isoxazole to oxazole: a mild and unexpected transformation. RSC Publishing. Available at: [\[Link\]](#)
- Fe-catalyzed ring opening isoxazoles. ResearchGate. Available at: [\[Link\]](#)
- Advances in isoxazole chemistry and their role in drug discovery. Semantic Scholar. Available at: [\[Link\]](#)
- Harnessing the Intrinsic Photochemistry of Isoxazoles for the Development of Chemoproteomic Crosslinking Methods. PMC - NIH. Available at: [\[Link\]](#)
- Harnessing the Intrinsic Photochemistry of Isoxazoles for the Development of Chemoproteomic Crosslinking Methods. bioRxiv. Available at: [\[Link\]](#)
- Structure and stability of isoxazoline compounds. ResearchGate. Available at: [\[Link\]](#)
- Synthetic route for the preparation of isoxazole derivatives. ResearchGate. Available at: [\[Link\]](#)
- The Green and Effective Synthesis of Isoxazole-Based Molecules Under Ultrasonic Irradiation Approaches. PubMed Central. Available at: [\[Link\]](#)
- Synthesis of Novel Isoxazole Derivatives as Analgesic Agents by Using Eddy's Hot Plate Method. SAR Publication. Available at: [\[Link\]](#)
- Nitrile. Wikipedia. Available at: [\[Link\]](#)
- Time-Resolved Photoelectron Spectroscopy Studies of Isoxazole and Oxazole. The Journal of Physical Chemistry A (ACS Publications). Available at: [\[Link\]](#)
- Harnessing the intrinsic photochemistry of isoxazoles for the development of chemoproteomic crosslinking methods. Chemical Communications (RSC Publishing). Available at: [\[Link\]](#)
- Experiment 5 Reductions with Lithium Aluminium Hydride. University of Southampton. Available at: [\[Link\]](#)

- Construction of Isoxazole ring: An Overview. ICONIC RESEARCH AND ENGINEERING JOURNALS. Available at: [\[Link\]](#)
- Thermal decomposition of isoxazole: experimental and modeling study. The Journal of Physical Chemistry (ACS Publications). Available at: [\[Link\]](#)
- Collision-induced dissociation of valdecoxib metabolites: a novel rearrangement involving an isoxazole ring. PubMed. Available at: [\[Link\]](#)
- Bioactivation of Isoxazole-Containing Bromodomain and Extra-Terminal Domain (BET) Inhibitors. PMC - PubMed Central. Available at: [\[Link\]](#)
- Isoxazoles. 4. Hydrolysis of sulfonamide isoxazole derivatives in concentrated sulfuric acid solutions. A new treatment of the medium effects on protonation equilibria and reaction rates. The Journal of Organic Chemistry (ACS Publications). Available at: [\[Link\]](#)
- Ring-Opening Fluorination of Isoxazoles. Organic Letters (ACS Publications). Available at: [\[Link\]](#)

Need Custom Synthesis?

BenchChem offers custom synthesis for rare earth carbides and specific isotopic labeling.

Email: info@benchchem.com or [Request Quote Online](#).

Sources

- [1. pdf.benchchem.com \[pdf.benchchem.com\]](#)
- [2. nanobioletters.com \[nanobioletters.com\]](#)
- [3. pdf.benchchem.com \[pdf.benchchem.com\]](#)
- [4. pdf.benchchem.com \[pdf.benchchem.com\]](#)
- [5. Isoxazoles. VI: Aspects of the chemical stability of a new naphthoquinone-amine in acidic aqueous solution - PubMed \[pubmed.ncbi.nlm.nih.gov\]](#)
- [6. pubs.acs.org \[pubs.acs.org\]](#)
- [7. researchgate.net \[researchgate.net\]](#)

- [8. researchgate.net \[researchgate.net\]](https://researchgate.net)
- [9. triggered.stanford.clockss.org \[triggered.stanford.clockss.org\]](https://triggered.stanford.clockss.org)
- [10. Reductive ring opening of isoxazoles with Mo\(CO\)₆ and water - Journal of the Chemical Society, Chemical Communications \(RSC Publishing\) \[pubs.rsc.org\]](https://pubs.rsc.org)
- [11. cdnsiencepub.com \[cdnsiencepub.com\]](https://cdnsiencepub.com)
- [12. ingentaconnect.com \[ingentaconnect.com\]](https://ingentaconnect.com)
- [13. researchgate.net \[researchgate.net\]](https://researchgate.net)
- [14. ch.ic.ac.uk \[ch.ic.ac.uk\]](https://ch.ic.ac.uk)
- [15. sciencegate.app \[sciencegate.app\]](https://sciencegate.app)
- [16. pubs.acs.org \[pubs.acs.org\]](https://pubs.acs.org)
- [17. Isoxazole to oxazole: a mild and unexpected transformation - Chemical Communications \(RSC Publishing\) DOI:10.1039/C4CC07999J \[pubs.rsc.org\]](https://pubs.rsc.org)
- [18. The Green and Effective Synthesis of Isoxazole-Based Molecules Under Ultrasonic Irradiation Approaches - PMC \[pmc.ncbi.nlm.nih.gov\]](https://pmc.ncbi.nlm.nih.gov)
- [19. Isoxazole - Wikipedia \[en.wikipedia.org\]](https://en.wikipedia.org)
- [20. Harnessing the Intrinsic Photochemistry of Isoxazoles for the Development of Chemoproteomic Crosslinking Methods - PMC \[pmc.ncbi.nlm.nih.gov\]](https://pmc.ncbi.nlm.nih.gov)
- [21. Harnessing the Intrinsic Photochemistry of Isoxazoles for the Development of Chemoproteomic Crosslinking Methods | bioRxiv \[biorxiv.org\]](https://biorxiv.org)
- [22. Harnessing the intrinsic photochemistry of isoxazoles for the development of chemoproteomic crosslinking methods - Chemical Communications \(RSC Publishing\) \[pubs.rsc.org\]](https://pubs.rsc.org)
- To cite this document: BenchChem. [Technical Support Center: Navigating the Stability of the Isoxazole Ring]. BenchChem, [2026]. [Online PDF]. Available at: [\[https://www.benchchem.com/product/b1267927/docs#technical-support-center-navigating-the-stability-of-the-isoxazole-ring\]](https://www.benchchem.com/product/b1267927/docs#technical-support-center-navigating-the-stability-of-the-isoxazole-ring)

Disclaimer & Data Validity:

The information provided in this document is for Research Use Only (RUO) and is strictly not intended for diagnostic or therapeutic procedures. While BenchChem strives to provide accurate protocols, we make no warranties, express or implied, regarding the fitness of this product for every specific experimental setup.

Technical Support: The protocols provided are for reference purposes. Unsure if this reagent suits your experiment?

Need Industrial/Bulk Grade? [Request Custom Synthesis Quote](#)

BenchChem

Our mission is to be the trusted global source of essential and advanced chemicals, empowering scientists and researchers to drive progress in science and industry.

Contact

Address: 3281 E Guasti Rd
Ontario, CA 91761, United States
Phone: (601) 213-4426
Email: info@benchchem.com

[Contact our Ph.D. Support Team for a compatibility check](#)