

Process Development & Scale-Up: Chemoselective Synthesis of (4-Aminophenyl) (phenyl)methanol

Author: BenchChem Technical Support Team. **Date:** May 2026

Compound of Interest

Compound Name: (4-Aminophenyl)(phenyl)methanol

CAS No.: 25782-57-4

Cat. No.: B1267711

[Get Quote](#)

Executive Summary & Strategic Analysis

(4-Aminophenyl)(phenyl)methanol (CAS: 25782-57-4), also known as 4-aminobenzhydrol, is a critical pharmacophore found in antihistamines, antifungal triazolones, and advanced polymer precursors.[1] While gram-scale synthesis is trivial in academic settings, scaling this process to kilogram quantities introduces thermodynamic and safety risks that must be engineered out of the workflow.

This Application Note details the chemoselective reduction of 4-aminobenzophenone using Sodium Borohydride (NaBH

). Unlike catalytic hydrogenation (which risks reducing the aromatic ring or poisoning catalysts via the amine) or Lithium Aluminum Hydride (which is too reactive for safe large-scale handling), NaBH

offers the ideal balance of cost, safety, and selectivity.

Critical Process Parameters (CPPs)

- **Thermal Management:** The hydride transfer is exothermic. Uncontrolled dosing leads to runaway temperatures and potential decomposition.
- **Hydrogen Evolution:** NaBH releases hydrogen gas upon contact with protic solvents and during the acid quench. Ventilation and headspace management are non-negotiable.
- **Chemoselectivity:** The protocol must reduce the ketone without affecting the nucleophilic aniline amine.

Material Attributes & stoichiometry

Component	Role	CAS No.	MW (g/mol)	Density	Equivalents
4-Aminobenzophenone	Substrate	1137-41-3	197.23	Solid	1.0
Sodium Borohydride	Reductant	16940-66-2	37.83	Solid	0.6 - 0.8*
Methanol	Solvent	67-56-1	32.04	0.792 g/mL	5-10 Vol
Water	Quench	7732-18-5	18.02	1.00 g/mL	Excess

*Note: Theoretically, 0.25 eq of NaBH

can reduce 1 eq of ketone (4 hydrides per B). In practice, 0.6–0.8 eq is used to drive kinetics and account for solvent-mediated decomposition.[1]

Reaction Mechanism & Pathway

The reduction proceeds via a nucleophilic attack of the borohydride anion on the carbonyl carbon.[2] The resulting alkoxyborate intermediate is hydrolyzed during the workup to yield the target alcohol.

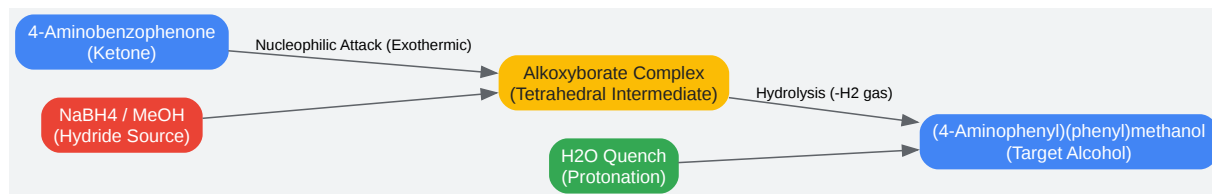

[Click to download full resolution via product page](#)

Figure 1: Mechanistic pathway for the borohydride reduction of diaryl ketones.

Scale-Up Protocol (1.0 kg Batch Basis)

Phase A: Reactor Setup & Dissolution

Objective: Create a homogeneous solution while excluding atmospheric moisture.

- Equipment: Use a 20 L Jacketed Glass Reactor equipped with an overhead stirrer (impeller type: pitch blade), reflux condenser, nitrogen inlet, and a solids addition funnel (or powder dosing valve).
- Inerting: Purge the reactor with Nitrogen (N₂) for 15 minutes.
- Charging:
 - Charge 1.0 kg (5.07 mol) of 4-Aminobenzophenone.
 - Charge 8.0 L of Methanol (MeOH).
 - Note: Ethanol can be used as a greener alternative, but Methanol generally offers better solubility for benzophenones.
- Dissolution: Agitate at 250 RPM at 20–25°C until the solid is fully dissolved. The solution will likely be yellow/amber.

Phase B: Controlled Reduction (The Critical Step)

Objective: Reduce the ketone while managing the exotherm and H

evolution.

- Cooling: Lower the jacket temperature to 0°C to achieve an internal temperature of 5–10°C.
- Dosing NaBH
 - :
 - Total NaBH
 - required: 153 g (4.05 mol, ~0.8 eq).
 - Protocol: Add NaBH
 - in 5 equal portions (approx. 30 g each) over 60 minutes (1 portion every 12 mins).
 - Constraint: Do not allow internal temperature to exceed 20°C. If temp spikes, halt addition and increase jacket cooling.
- Reaction Maintenance:
 - After final addition, remove cooling and allow the mixture to warm to 20–25°C.
 - Stir for 2–4 hours.
- In-Process Control (IPC):
 - Sample 50 µL, quench in water/MeCN, and analyze via HPLC.
 - Specification: < 1.0% residual ketone.

Phase C: Quench & Isolation

Objective: Decompose excess borohydride and isolate the product.

- Quench Preparation: Cool the reactor back to 10°C.

- Hydrolysis:
 - Slowly add 2.0 L of Water over 30 minutes.
 - Warning: Significant H
gas evolution will occur. Ensure reactor vent is open to a scrubber or fume extraction.
 - pH Adjustment: The pH will be basic (borate salts). Neutralize carefully to pH 7–8 using dilute Acetic Acid or HCl (1M). Do not over-acidify, or you will form the hydrochloride salt of the amine, which is water-soluble and will be lost in the mother liquor.
- Crystallization/Precipitation:
 - Add an additional 4.0 L of Water to force precipitation of the benzhydrol.
 - Stir at 5°C for 2 hours to age the crystals.
- Filtration: Filter the slurry using a nutsche filter or centrifuge.
- Washing: Wash the cake with 2 x 1.0 L of Water (chilled) to remove inorganic salts (NaBO
).
- Drying: Dry in a vacuum oven at 45°C for 12 hours.

Process Flow Diagram

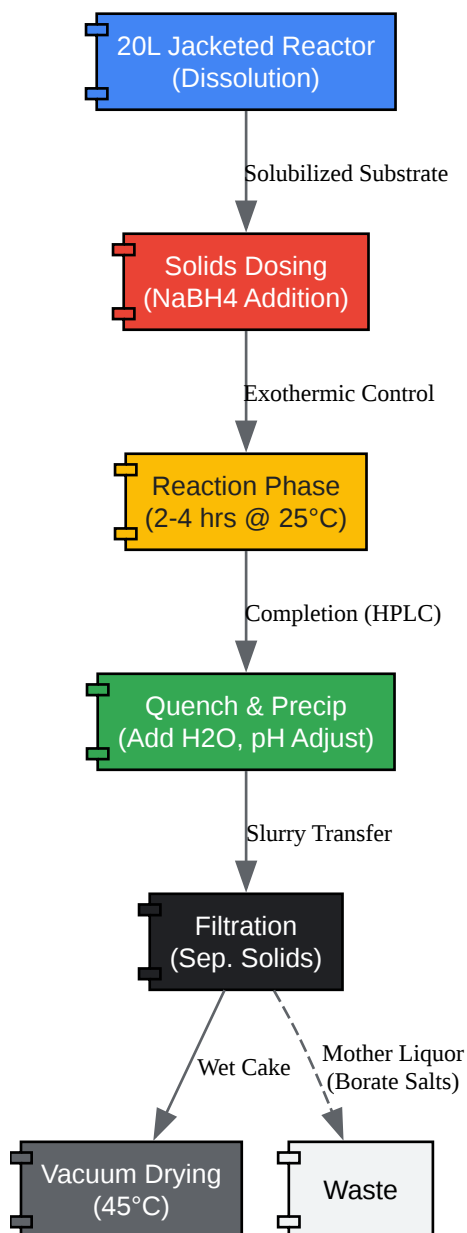

[Click to download full resolution via product page](#)

Figure 2: Unit operation workflow for the kilogram-scale synthesis.[1]

Safety & Risk Assessment (E-E-A-T)[1]

Hydrogen Management

Sodium Borohydride releases hydrogen gas upon contact with water or alcohols, particularly under acidic conditions or elevated temperatures.

- Risk: Explosion if H

accumulates in the headspace.

- Mitigation: Maintain a constant N

sweep (low flow) during the quench to dilute evolved H

below the Lower Explosive Limit (LEL). Ensure the reactor is grounded to prevent static discharge.

Thermal Runaway

The reduction is exothermic.

- Risk: Rapid addition of NaBH

can cause solvent boiling (MeOH bp: 64.7°C).

- Mitigation: Strict temperature limits (<20°C during dosing). Use of a "dead-man" switch on the dosing mechanism or manual addition protocols that require temperature checks before every scoop.

Toxicity[7][8][9]

- Methanol: Toxic by ingestion/inhalation.[3][4]

- NaBH

: Toxic if swallowed; causes severe skin burns.[4][5] reacts violently with water.[4]

- Product: Handle as a potential irritant/bioactive amine.

Troubleshooting Guide

Issue	Probable Cause	Corrective Action
Incomplete Conversion	Moisture in solvent consumed NaBH .[1]	Add an extra 0.1–0.2 eq of NaBH . Ensure solvent is dry (KF < 0.1%).
Oiling Out	Product precipitated too fast or impurities present.	Re-heat to dissolve, then cool slowly (5°C/hour) to induce crystallization.
Low Yield	Product lost during filtration (pH too low).	Check pH of mother liquor. If < 7, the amine is protonated. Neutralize with NaOH and re-filter.
Color Issues	Oxidation of the aniline amine.	Perform all steps under strict Nitrogen atmosphere. Add trace EDTA if metal ions are suspected.

References

- PubChem. (n.d.).[6] **(4-Aminophenyl)(phenyl)methanol** (CAS 25782-57-4).[1][7][8][6][9] National Library of Medicine. Retrieved from [\[Link\]](#)
- UC Santa Barbara. (2012). Standard Operating Procedure: Sodium Borohydride.[4] UCSB Environmental Health & Safety. Retrieved from [\[Link\]](#)
- Chemguide. (2023). The Reduction of Aldehydes and Ketones using Sodium Tetrahydridoborate. Retrieved from [\[Link\]](#)
- Google Patents. (2002). Process for preparing N-(4-hydroxyphenyl)-N'-(4'-aminophenyl)-piperazine (EP1230231B1).[1] Retrieved from

Need Custom Synthesis?

BenchChem offers custom synthesis for rare earth carbides and specific isotopic labeling.

Email: info@benchchem.com or [Request Quote Online](#).

Sources

- 1. (4-AMINOMETHYL-PHENYL)-METHANOL | 39895-56-2 [chemicalbook.com]
- 2. 3.4.1 – Sodium Borohydride Reduction of Carbonyls – Page 2 – Organic Chemistry and Chemical Biology for the Students by the Students! (and the Profs...) [ecampusontario.pressbooks.pub]
- 3. dept.harpercollege.edu [dept.harpercollege.edu]
- 4. sites.chemengr.ucsb.edu [sites.chemengr.ucsb.edu]
- 5. nj.gov [nj.gov]
- 6. (4-Aminophenyl)(phenyl)methanol | C₁₃H₁₃NO | CID 242216 - PubChem [pubchem.ncbi.nlm.nih.gov]
- 7. chemscene.com [chemscene.com]
- 8. 25782-57-4[(4-Aminophenyl)(phenyl)methanol]|BLD Pharm [bldpharm.com]
- 9. (4-Aminophenyl)(phenyl)methanol | CymitQuimica [cymitquimica.com]
- To cite this document: BenchChem. [Process Development & Scale-Up: Chemoselective Synthesis of (4-Aminophenyl)(phenyl)methanol]. BenchChem, [2026]. [Online PDF]. Available at: [<https://www.benchchem.com/product/b1267711/docs#process-development-scale-up-chemoselective-synthesis-of-4-aminophenyl-phenyl-methanol>]

Disclaimer & Data Validity:

The information provided in this document is for Research Use Only (RUO) and is strictly not intended for diagnostic or therapeutic procedures. While BenchChem strives to provide accurate protocols, we make no warranties, express or implied, regarding the fitness of this product for every specific experimental setup.

Technical Support: The protocols provided are for reference purposes. Unsure if this reagent suits your experiment?

Need Industrial/Bulk Grade? [Request Custom Synthesis Quote](#)

BenchChem

Our mission is to be the trusted global source of essential and advanced chemicals, empowering scientists and researchers to drive progress in science and industry.

Contact

Address: 3281 E Guasti Rd
Ontario, CA 91761, United States
Phone: (601) 213-4426
Email: info@benchchem.com

[Contact our Ph.D. Support Team for a compatibility check](#)