

Introduction: Unveiling the Potential of 3-Benzylphenol

Author: BenchChem Technical Support Team. **Date:** May 2026

Compound of Interest

Compound Name: 3-Benzylphenol

CAS No.: 22272-48-6

Cat. No.: B1267012

[Get Quote](#)

3-Benzylphenol is a phenolic compound characterized by a hydroxyl group attached to a benzene ring, which is further substituted with a benzyl group at the meta position. While structurally related to well-known antioxidants like resveratrol and other polyphenols, **3-Benzylphenol** presents a unique spatial and electronic configuration that dictates its antioxidant potential. Its significance in medicinal chemistry and materials science is growing, particularly for its role as a potent free radical scavenger and a modulator of cellular oxidative stress responses.

This technical guide provides an in-depth exploration of the antioxidant mechanisms of **3-Benzylphenol**. Moving beyond a general overview, we will dissect the core chemical principles, present validated experimental protocols for its characterization, and explore its interaction with cellular signaling pathways. The methodologies and insights herein are designed to equip researchers with the knowledge to rigorously evaluate and harness the antioxidant capabilities of this compound.

Section 1: The Chemical Basis of Antioxidant Action

The antioxidant activity of **3-Benzylphenol** is fundamentally rooted in the reactivity of its phenolic hydroxyl (-OH) group. The benzyl substituent, while not directly participating in radical scavenging, modulates the electronic properties of the phenol ring, influencing the stability of the resulting phenoxyl radical. The primary mechanisms of radical neutralization are Hydrogen Atom Transfer (HAT) and Single Electron Transfer (SET).

Hydrogen Atom Transfer (HAT) Mechanism

In the HAT mechanism, the phenolic hydroxyl group donates its hydrogen atom to a free radical ($R\cdot$), effectively neutralizing it and forming a stable, resonance-stabilized phenoxyl radical. This is considered the most significant mechanism for phenolic antioxidants.

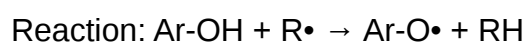

The stability of the resulting 3-benzylphenoxyl radical is paramount. The unpaired electron can be delocalized across the aromatic ring through resonance, which significantly lowers its reactivity and prevents it from initiating further radical chain reactions. The meta-position of the benzyl group influences this stabilization by inductive effects.

Single Electron Transfer (SET) Mechanism

The SET mechanism involves the transfer of a single electron from the phenol to the free radical, forming a radical cation and an anion. This is often followed by proton transfer (Proton-Coupled Electron Transfer, PCET) to yield the same phenoxyl radical as in the HAT pathway.



The favorability of HAT versus SET is dependent on factors such as the solvent polarity and the nature of the free radical. In non-polar environments, HAT is generally the dominant pathway.

Diagram 1: Core Antioxidant Mechanisms of **3-Benzylphenol**

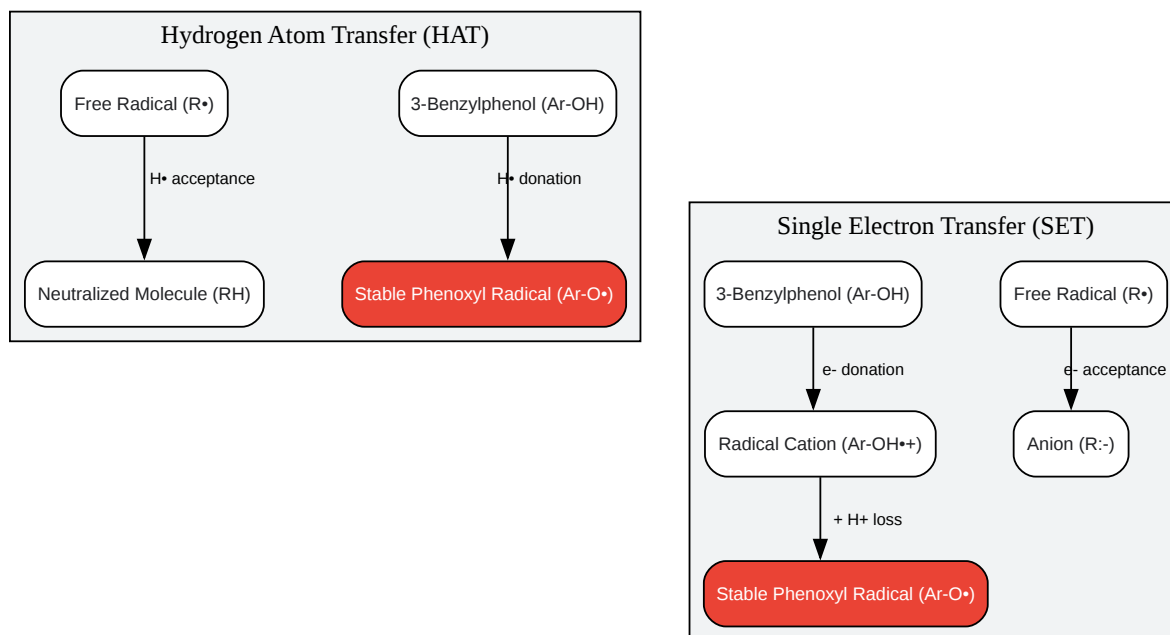

[Click to download full resolution via product page](#)

Caption: Primary chemical pathways for free radical neutralization by **3-Benzylphenol**.

Section 2: In Vitro Quantification of Antioxidant Capacity

To empirically validate the antioxidant activity of **3-Benzylphenol**, a series of standardized in vitro assays are essential. These assays measure the compound's ability to scavenge synthetic free radicals. A multi-assay approach is recommended, as different assays reflect different aspects of antioxidant action.

DPPH (2,2-diphenyl-1-picrylhydrazyl) Radical Scavenging Assay

This is one of the most common and reliable methods for evaluating antioxidant capacity. The DPPH radical is a stable free radical with a deep violet color. When it accepts a hydrogen atom or an electron from an antioxidant, it is reduced to the yellow-colored diphenylpicrylhydrazine. The rate of color change is proportional to the antioxidant's scavenging ability.

Experimental Protocol: DPPH Assay

- Reagent Preparation:
 - Prepare a 0.1 mM solution of DPPH in 95% methanol. Store in an amber bottle at 4°C.
 - Prepare a stock solution of **3-Benzylphenol** (e.g., 1 mg/mL) in methanol. Create a dilution series (e.g., 100, 50, 25, 12.5, 6.25 µg/mL).
 - Ascorbic acid or Trolox should be used as a positive control.
- Assay Procedure:
 - In a 96-well microplate, add 100 µL of each **3-Benzylphenol** dilution.
 - Add 100 µL of the 0.1 mM DPPH solution to each well.
 - For the blank, add 100 µL of methanol and 100 µL of DPPH solution.
 - Incubate the plate in the dark at room temperature for 30 minutes.
- Data Acquisition:
 - Measure the absorbance at 517 nm using a microplate reader.
 - Calculate the percentage of radical scavenging activity using the formula:
 - % Inhibition = $[(\text{Abs_blank} - \text{Abs_sample}) / \text{Abs_blank}] * 100$
- Analysis:
 - Plot the % inhibition against the concentration of **3-Benzylphenol**.

- Determine the IC₅₀ value (the concentration required to scavenge 50% of DPPH radicals) from the graph. A lower IC₅₀ value indicates higher antioxidant activity.

Diagram 2: Experimental Workflow for the DPPH Assay

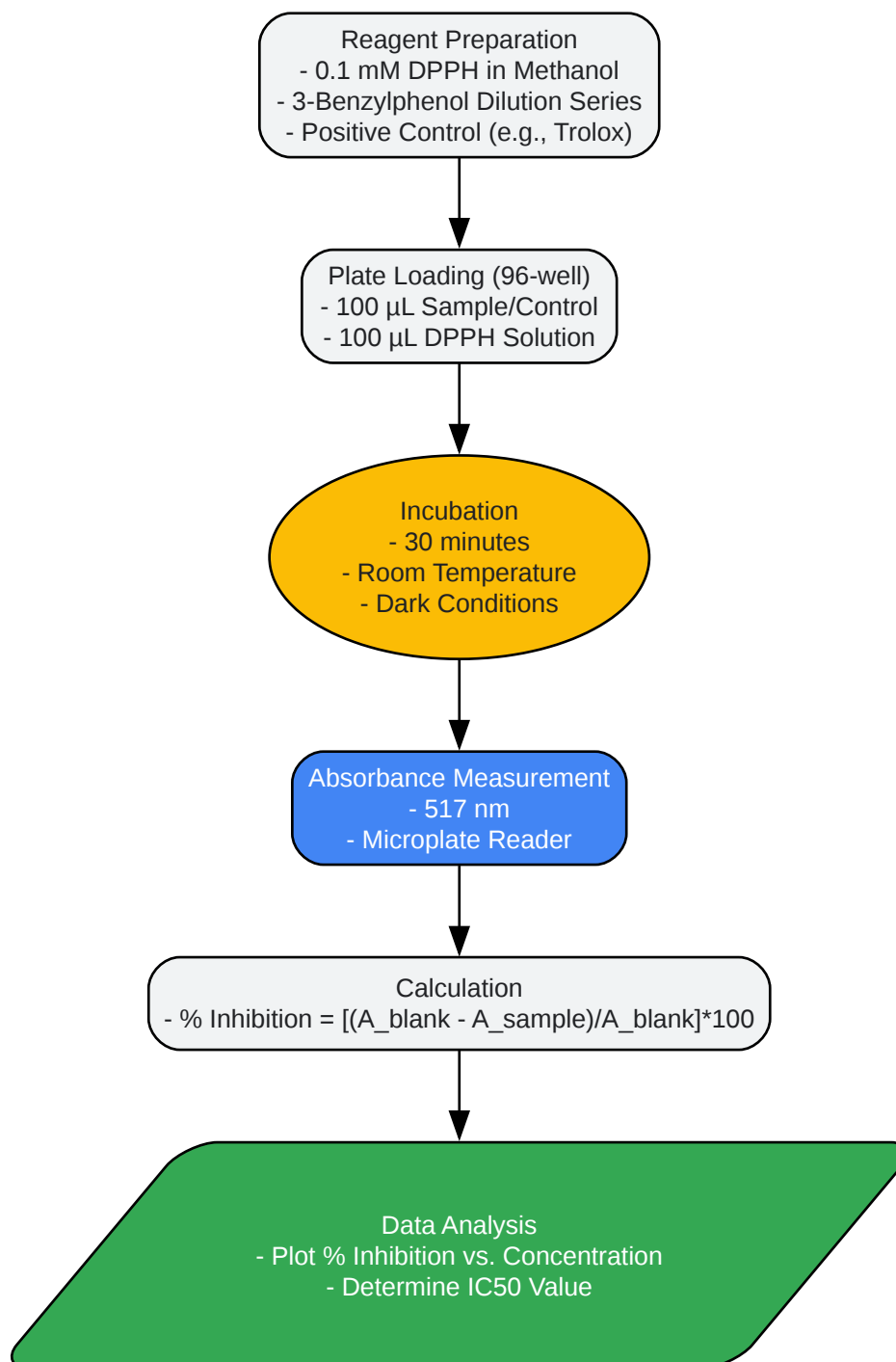

[Click to download full resolution via product page](#)

Caption: Standardized workflow for assessing antioxidant capacity using the DPPH assay.

ABTS (2,2'-azino-bis(3-ethylbenzothiazoline-6-sulfonic acid)) Assay

The ABTS assay measures the ability of an antioxidant to scavenge the ABTS radical cation (ABTS•+). This radical is generated by oxidizing ABTS with potassium persulfate and has a characteristic blue-green color. The addition of an antioxidant reduces the ABTS•+, leading to a loss of color. This assay is advantageous as it can be used at different pH levels and is applicable to both hydrophilic and lipophilic compounds.

Assay	Principle	Radical Source	Wavelength	Key Advantage
DPPH	H-atom/electron donation	Stable DPPH radical	517 nm	Simple, rapid, and widely used.
ABTS	H-atom/electron donation	Pre-formed ABTS•+	734 nm	Applicable to a wide pH range and compound types.
ORAC	H-atom transfer	Peroxy radicals (AAPH)	485/520 nm	Measures inhibition of radical chain reaction over time; biologically relevant radical.

Table 1: Comparison of common in vitro antioxidant capacity assays.

Section 3: Cellular Antioxidant Mechanisms

Beyond direct chemical scavenging, potent antioxidants like **3-Benzylphenol** can exert protective effects by modulating endogenous cellular antioxidant systems. A primary pathway is the activation of the Nuclear factor erythroid 2-related factor 2 (Nrf2) signaling pathway.

Activation of the Nrf2-ARE Pathway

Under normal conditions, Nrf2 is sequestered in the cytoplasm by its inhibitor, Kelch-like ECH-associated protein 1 (Keap1), which facilitates its degradation. Electrophilic or oxidative stress, potentially induced by compounds like **3-Benzylphenol** or its metabolites, can cause conformational changes in Keap1. This disrupts the Nrf2-Keap1 interaction, leading to the stabilization and nuclear translocation of Nrf2.

Once in the nucleus, Nrf2 heterodimerizes with small Maf proteins and binds to the Antioxidant Response Element (ARE) in the promoter region of various target genes. This upregulates the expression of a suite of protective enzymes, including:

- Heme Oxygenase-1 (HO-1): Catalyzes the degradation of pro-oxidant heme.
- NAD(P)H:quinone oxidoreductase 1 (NQO1): A detoxifying enzyme that reduces quinones.
- Glutamate-cysteine ligase (GCL): The rate-limiting enzyme in the synthesis of glutathione (GSH), the cell's primary endogenous antioxidant.

This response fortifies the cell against subsequent oxidative insults, an effect known as indirect antioxidant activity.

Diagram 3: Nrf2-ARE Signaling Pathway Activation

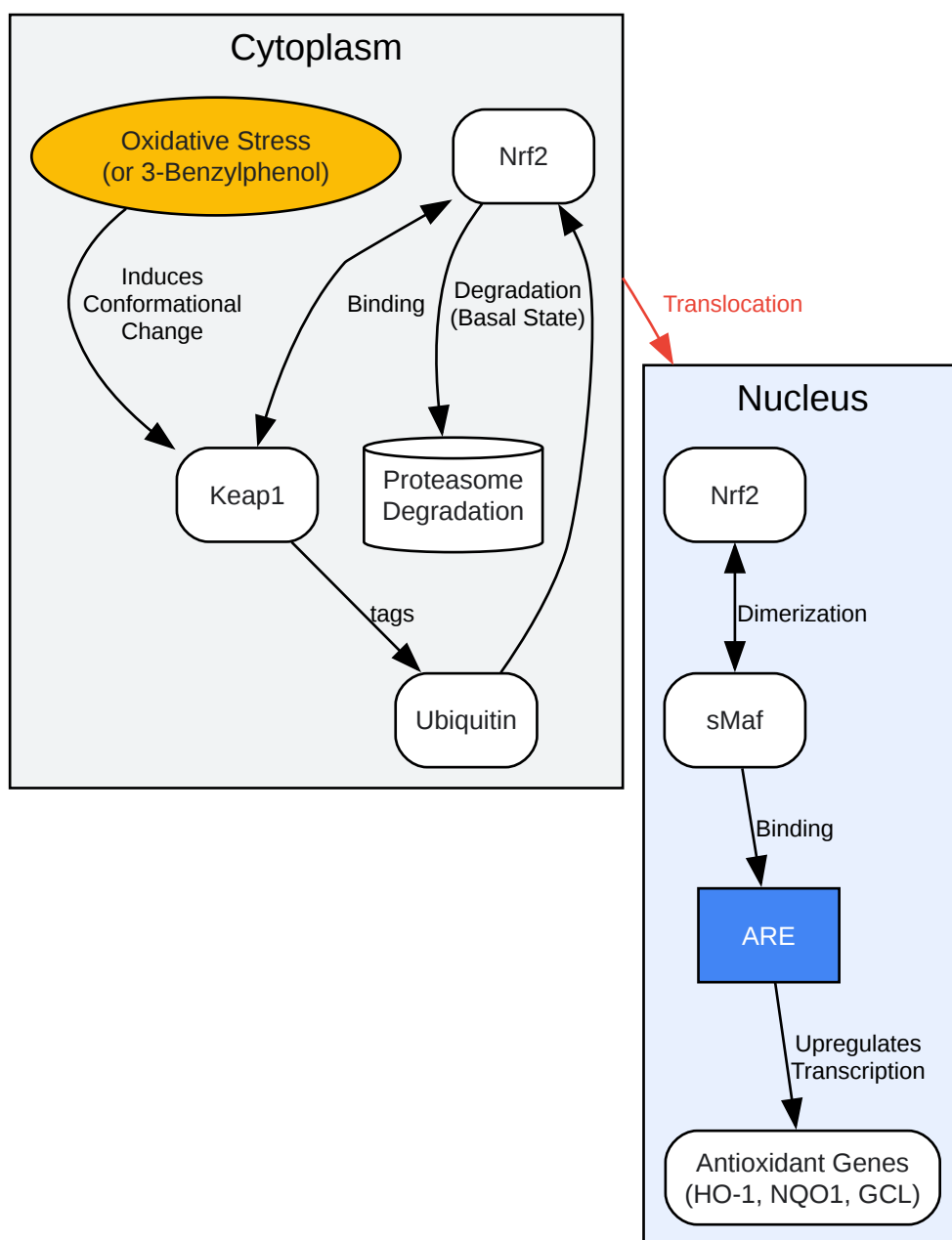

[Click to download full resolution via product page](#)

Caption: Activation of the Nrf2-ARE pathway as an indirect antioxidant mechanism.

Cellular Assay: Measuring Intracellular Reactive Oxygen Species (ROS)

To assess the efficacy of **3-Benzylphenol** within a biological context, the 2',7'-dichlorofluorescein diacetate (DCFH-DA) assay is widely employed. DCFH-DA is a cell-

permeable probe that is deacetylated by intracellular esterases to DCFH. In the presence of ROS, DCFH is oxidized to the highly fluorescent dichlorofluorescein (DCF). A reduction in fluorescence in cells pre-treated with **3-Benzylphenol** indicates a decrease in intracellular ROS.

Experimental Protocol: DCFH-DA Assay

- Cell Culture:
 - Seed cells (e.g., HaCaT or HepG2) in a 96-well black, clear-bottom plate and culture until they reach 80-90% confluency.
- Compound Treatment:
 - Pre-treat cells with various non-toxic concentrations of **3-Benzylphenol** for a specified period (e.g., 2-4 hours). Include a vehicle control.
- ROS Induction & Staining:
 - Remove the treatment media and wash cells with phosphate-buffered saline (PBS).
 - Induce oxidative stress by adding an agent like H₂O₂ or UV-A radiation. Include a non-stressed control group.
 - After induction, load the cells with 10 μM DCFH-DA solution in serum-free media and incubate for 30 minutes at 37°C in the dark.
- Data Acquisition:
 - Wash the cells again with PBS to remove excess probe.
 - Measure the fluorescence intensity using a microplate reader with excitation at ~485 nm and emission at ~530 nm.
- Analysis:
 - Normalize the fluorescence of treated groups to the control group that received only the oxidative stressor. A statistically significant decrease in fluorescence indicates the

compound's ability to mitigate intracellular ROS.

Conclusion and Future Directions

3-Benzylphenol demonstrates significant antioxidant capabilities through a combination of direct free-radical scavenging (via HAT and SET mechanisms) and indirect cellular defense modulation (via Nrf2-ARE pathway activation). Its efficacy is dictated by the reactivity of its phenolic hydroxyl group, which is electronically influenced by the benzyl substituent.

Future research should focus on a more detailed structure-activity relationship (SAR) analysis by comparing **3-Benzylphenol** with its 2- and 4-isomers. Furthermore, investigating its metabolic fate and the antioxidant activity of its metabolites is crucial for understanding its overall in vivo efficacy and potential for therapeutic development. Advanced studies employing electron paramagnetic resonance (EPR) spectroscopy could provide definitive evidence of radical scavenging and adduct formation. By combining these robust in vitro and cellular assays, researchers can build a comprehensive profile of **3-Benzylphenol**, paving the way for its application in pharmaceuticals and functional materials.

References

- DPPH Assay and Antioxidant Activity of Phenolic Compounds. (Source: Molecules, MDPI) [\[Link\]](#)
- ABTS Radical Cation Scavenging Assay. (Source: Nature Protocols) [\[Link\]](#)
- The Nrf2-ARE Signaling Pathway: An Update on Its Regulation and Possible Roles in Cancer. (Source: Frontiers in Oncology) [\[Link\]](#)
- Measurement of Reactive Oxygen Species by Fluorescent Probes. (Source: Methods in Molecular Biology, Springer) [\[Link\]](#)
- Structure-Activity Relationship of Phenolic Antioxidants. (Source: Critical Reviews in Food Science and Nutrition, Taylor & Francis) [\[Link\]](#)
- **3-Benzylphenol** Compound Summary. (Source: PubChem, National Center for Biotechnology Information) [\[Link\]](#)

- To cite this document: BenchChem. [Introduction: Unveiling the Potential of 3-Benzylphenol]. BenchChem, [2026]. [Online PDF]. Available at: [<https://www.benchchem.com/product/b1267012/docs#introduction-unveiling-the-potential-of-3-benzylphenol>]

Disclaimer & Data Validity:

The information provided in this document is for Research Use Only (RUO) and is strictly not intended for diagnostic or therapeutic procedures. While BenchChem strives to provide accurate protocols, we make no warranties, express or implied, regarding the fitness of this product for every specific experimental setup.

Technical Support: The protocols provided are for reference purposes. Unsure if this reagent suits your experiment?

Need Industrial/Bulk Grade? [Request Custom Synthesis Quote](#)

BenchChem

Our mission is to be the trusted global source of essential and advanced chemicals, empowering scientists and researchers to drive progress in science and industry.

Contact

Address: 3281 E Guasti Rd
Ontario, CA 91761, United States
Phone: (601) 213-4426
Email: info@benchchem.com

[Contact our Ph.D. Support Team for a compatibility check](#)