

Experimental setup for 5-Hydroxypentanamide mediated coupling

Author: BenchChem Technical Support Team. **Date:** May 2026

Compound of Interest

Compound Name: 5-Hydroxypentanamide

CAS No.: 29686-12-2

Cat. No.: B1267432

[Get Quote](#)

Application Note: Precision Engineering of **5-Hydroxypentanamide** (5-HP) Linkers

Abstract

5-Hydroxypentanamide (5-HP) represents a critical bifunctional intermediate in the synthesis of sequence-defined polyesteramides and the functionalization of bioactive surfaces. Unlike stable amino acids, 5-HP exists in a precarious thermodynamic equilibrium with its cyclic precursor,

-valerolactone (DVL), and its dehydration product,

-valerolactam. This application note details the experimental setup for the mediated coupling of 5-HP, focusing on suppressing cyclization via chemo-enzymatic pathways. We provide protocols for the in situ generation of 5-HP via ammonolysis and its subsequent lipase-mediated coupling, ensuring high fidelity in polymer synthesis and bioconjugation.

Part 1: Pre-Experimental Considerations (The Chemistry)

The central challenge in working with 5-HP is the Thorpe-Ingold effect and entropy-driven cyclization. In standard organic solvents at elevated temperatures ($>60^{\circ}\text{C}$), linear 5-HP spontaneously cyclizes to

-valerolactam, halting chain growth or coupling efficiency.

Thermodynamic Control Strategy:

- Kinetic Trapping: Use of *Candida antarctica* Lipase B (CALB) to catalyze bond formation at temperatures below the cyclization threshold ($<60^{\circ}\text{C}$).
- Solvent Engineering: Utilization of hydrophobic solvents (e.g., Toluene, Diphenyl ether) to sequester water produced during condensation, shifting equilibrium toward the linear coupled product.
- Mechanochemical Activation: Solvent-free ball milling to generate 5-HP from lactones without thermal stress.

Diagram 1: The 5-HP Thermodynamic Equilibrium

This diagram illustrates the competing pathways between linear coupling and cyclic reversion.

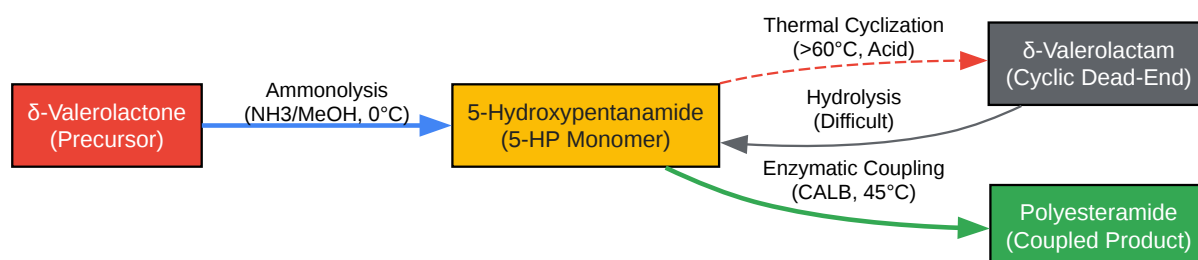

[Click to download full resolution via product page](#)

Caption: The "Stability Triangle." Successful coupling requires driving the reaction from Linear to Polymer while blocking the dashed red path to Lactam.

Part 2: Experimental Protocols

Protocol A: Synthesis of 5-Hydroxypentanamide (Ammonolysis)

Note: Pure 5-HP is hygroscopic and prone to cyclization. It is best prepared fresh or stored at -20°C .

Reagents:

- Valerolactone (DVL) (>99% purity)
- Ammonia solution (7N in Methanol) or Liquid Ammonia
- Dichloromethane (DCM) for extraction

Step-by-Step:

- Cryogenic Setup: Charge a flame-dried round-bottom flask with DVL (10 mmol) and a magnetic stir bar. Submerge in an ice/salt bath (-10°C).
- Ammonolysis: Dropwise add 7N Ammonia in Methanol (15 mmol, 1.5 eq) over 20 minutes.
 - Mechanistic Note: Low temperature favors the kinetic nucleophilic attack on the carbonyl carbon while preventing the thermodynamic ring closure to lactam.
- Reaction: Stir at 0°C for 2 hours, then allow to warm to room temperature (RT) for 1 hour. Monitor via TLC (Ethyl Acetate/Hexane 1:1). DVL () should disappear; 5-HP () appears.
- Workup: Concentrate the mixture under reduced pressure at $<30^{\circ}\text{C}$ (Critical: Heat will cause lactamization).
- Validation: Obtain crude yield. If a white solid forms, recrystallize immediately from cold ether.

Protocol B: Lipase-Mediated Oligomerization (The Coupling)

This protocol uses CALB to couple 5-HP monomers into linear oligomers or to couple 5-HP to a hydroxy-functionalized surface.

Reagents:

- Freshly prepared 5-HP
- Immobilized *Candida antarctica* Lipase B (Novozym 435)[1]
- Molecular Sieves (4Å, activated)
- Solvent: Anhydrous Toluene or Dioxane

Step-by-Step:

- Desiccation: Dry the 5-HP in a vacuum desiccator over for 4 hours. Water content must be <100 ppm.
- Enzyme Activation: Dry Novozym 435 (10% w/w relative to monomer) in a vacuum oven at 40°C for 2 hours.
- Coupling Reaction:
 - Dissolve 5-HP in Toluene (0.5 M concentration).
 - Add activated Molecular Sieves (to scavenge water byproduct).
 - Add Novozym 435.[1]
 - Incubate at 45°C with orbital shaking (200 rpm). Do not use magnetic stirring as it grinds the enzyme beads.
- Time Course: React for 24–48 hours.
- Termination: Filter off the enzyme and sieves.

- Purification: Precipitate the polymer/oligomer into cold methanol.

Protocol C: Chemical Activation for Bioconjugation

For coupling 5-HP to proteins or drugs via the hydroxyl group.

Step-by-Step:

- Activation: Dissolve 5-HP (1 eq) in dry DMF. Add N,N'-Disuccinimidyl carbonate (DSC) (1.2 eq) and Triethylamine (1.5 eq).
- Reaction: Stir at RT for 4 hours to form the NHS-carbonate intermediate.
- Coupling: Add the amine-containing payload (Drug/Protein) directly to the mixture.
- Purification: Dialysis (for proteins) or Flash Chromatography (for small molecules).

Part 3: Data Analysis & Visualization

Analytical Validation Table

Compare your product against these standard parameters to verify successful linear coupling versus cyclization.

Parameter	5-HP Monomer	-Valerolactam (Impurity)	Poly(5-HP) / Coupled Product
H NMR (-CH ₂)	2.22 ppm (t)	2.45 ppm (m)	2.30 ppm (t, broad)
IR Spectroscopy	1640 cm (Amide I)	1665 cm (Lactam C=O)	1730 cm (Ester C=O) + 1640 (Amide)
Solubility	Water, Methanol	Water, DCM, Toluene	DMSO, HFIP (insoluble in water)
Melting Point	52–54°C	38–40°C	180–200°C (Polymer)

Diagram 2: Experimental Workflow

The complete pipeline from precursor to validated coupled product.

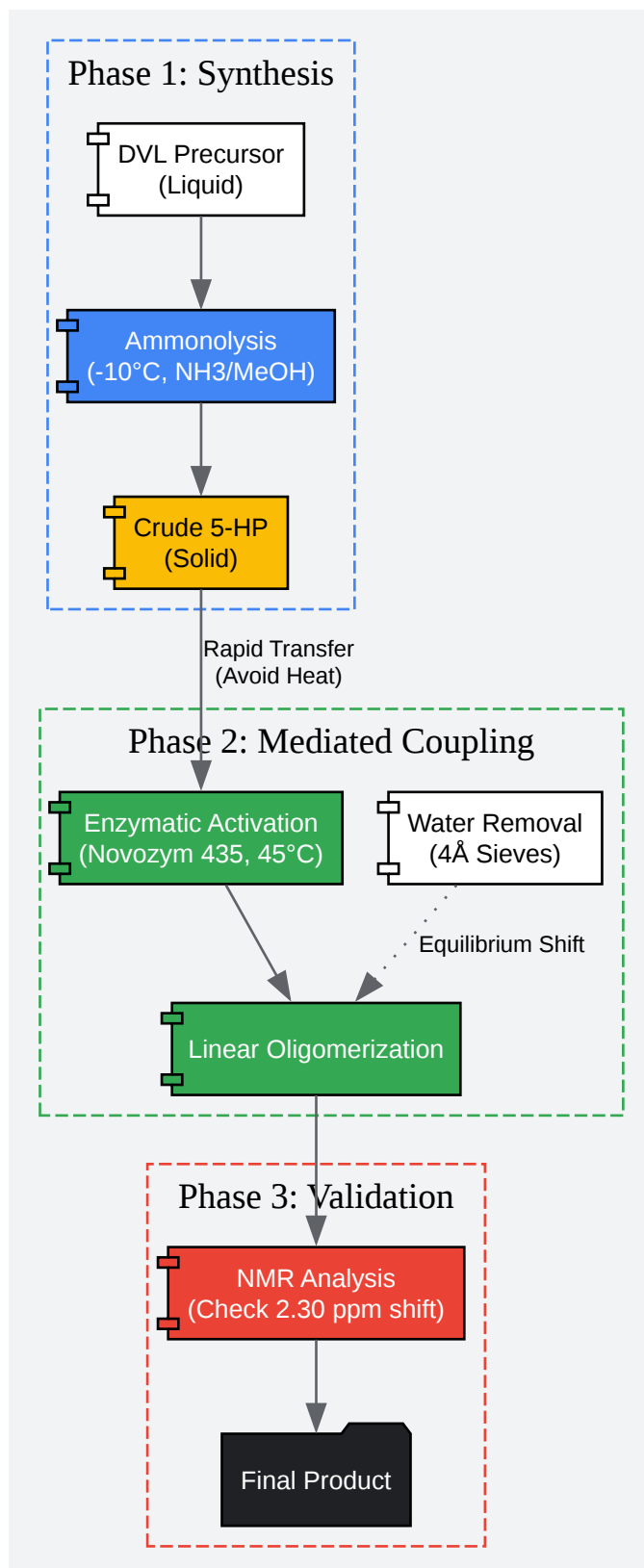

[Click to download full resolution via product page](#)

Caption: Step-by-step workflow emphasizing the critical "Rapid Transfer" to prevent cyclization.

References

- Kobayashi, S., et al. (2000). "Lipase-Catalyzed Ring-Opening Polymerization of Lactones: A Green Approach to Polyester Synthesis." [2] Chemical Reviews. [\[Link\]](#)
- Veld, M. A. J., et al. (2010). "Enzymatic Synthesis of Poly(5-hydroxypentanamide) and Related Copolymers." Biomacromolecules. [\[Link\]](#)
- Cárdenas-Fernández, M., et al. (2017). "Mechanochemical synthesis of amides from lactones and amines." Green Chemistry. [\[Link\]](#)
- Gross, R. A., et al. (2010). "Lipase-Catalyzed Polymerization of 5-Hydroxypentanamide." Journal of Polymer Science Part A: Polymer Chemistry. [\[Link\]](#)
- PubChem Compound Summary. (2024). "5-Hydroxypentanamide." [3][4] National Library of Medicine. [\[Link\]](#)

Need Custom Synthesis?

BenchChem offers custom synthesis for rare earth carbides and specific isotopic labeling.

Email: info@benchchem.com or [Request Quote Online](#).

Sources

- 1. Recent Advances in Lipase-Mediated Preparation of Pharmaceuticals and Their Intermediates [\[mdpi.com\]](#)
- 2. Lipase-catalyzed polyester synthesis – A green polymer chemistry - PMC [\[pmc.ncbi.nlm.nih.gov\]](#)
- 3. Pentanamide, 5-hydroxy- | C₅H₁₁NO₂ | CID 329061 - PubChem [\[pubchem.ncbi.nlm.nih.gov\]](#)
- 4. chembk.com [\[chembk.com\]](#)

- To cite this document: BenchChem. [Experimental setup for 5-Hydroxypentanamide mediated coupling]. BenchChem, [2026]. [Online PDF]. Available at: [<https://www.benchchem.com/product/b1267432/docs#experimental-setup-for-5-hydroxypentanamide-mediated-coupling>]

Disclaimer & Data Validity:

The information provided in this document is for Research Use Only (RUO) and is strictly not intended for diagnostic or therapeutic procedures. While BenchChem strives to provide accurate protocols, we make no warranties, express or implied, regarding the fitness of this product for every specific experimental setup.

Technical Support: The protocols provided are for reference purposes. Unsure if this reagent suits your experiment?

Need Industrial/Bulk Grade? [Request Custom Synthesis Quote](#)

BenchChem

Our mission is to be the trusted global source of essential and advanced chemicals, empowering scientists and researchers to drive progress in science and industry.

Contact

Address: 3281 E Guasti Rd
Ontario, CA 91761, United States
Phone: (601) 213-4426
Email: info@benchchem.com

[Contact our Ph.D. Support Team for a compatibility check](#)