

Application Note: Strategic Synthesis of Herbicides using 3-Bromo-5-nitrobenzoic Acid

Author: BenchChem Technical Support Team. **Date:** May 2026

Compound of Interest

Compound Name:	3-Bromo-5-nitrobenzoic acid
CAS No.:	6307-83-1
Cat. No.:	B1267607

[Get Quote](#)

Executive Summary

In the competitive landscape of agrochemical discovery, **3-Bromo-5-nitrobenzoic acid** represents a "privileged scaffold" due to its unique tri-functional architecture. Unlike simple benzoic acid derivatives, this molecule offers three distinct orthogonal reactive sites: a carboxylic acid (for solubility/esterification), a nitro group (a latent amine for heterocycle construction), and a bromine atom (a handle for cross-coupling).

This guide details the strategic application of **3-Bromo-5-nitrobenzoic acid** in synthesizing Protoporphyrinogen Oxidase (PPO) inhibiting herbicides and Benzamide-class growth regulators. We provide a validated protocol for the conversion of this scaffold into high-value 3-amino-5-bromobenzoate intermediates, followed by downstream functionalization.

Chemical Profile & Strategic Utility

The Tri-Functional Advantage

The core value of **3-Bromo-5-nitrobenzoic acid** lies in its ability to undergo sequential, selective functionalization. This allows researchers to "grow" the herbicide molecule in specific

vectors.

Functional Group	Reactivity Mode	Agrochemical Application
-COOH (C1)	Esterification / Amidation	Solubilizing tail or receptor binding motif (e.g., in Auxinic herbicides).
-NO ₂ (C3)	Reduction to -NH ₂	Precursor for N-phenyl uracils, phthalimides, or sulfonamides (PPO inhibitors).
-Br (C5)	Pd-Catalyzed Coupling	Attachment of lipophilic biaryl side chains (Suzuki) or alkynes (Sonogashira) to tune LogP and metabolic stability.

Strategic Pathway Visualization

The following diagram illustrates the divergent synthetic pathways accessible from this single starting material.

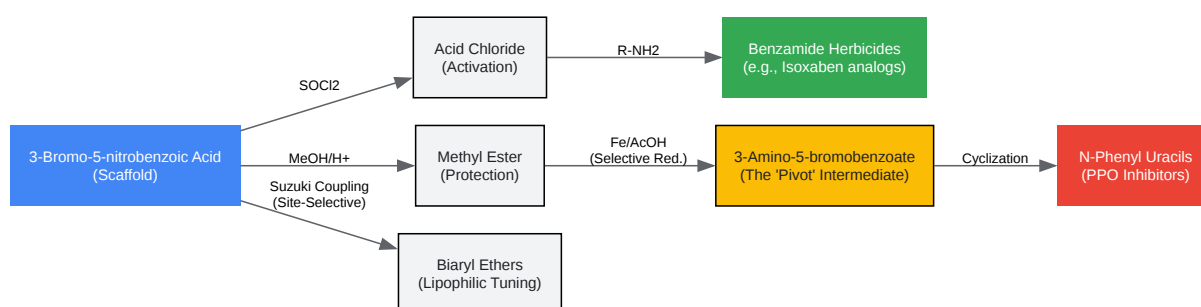

[Click to download full resolution via product page](#)

Figure 1: Divergent synthetic utility of **3-Bromo-5-nitrobenzoic acid** in herbicide development.

Detailed Experimental Protocols

The following protocols focus on the "Aniline Route" (Path 2 in Fig 1), as this generates Methyl 3-amino-5-bromobenzoate, the most versatile intermediate for modern herbicide synthesis (e.g., Saflufenacil analogs).

Step 1: Fischer Esterification (Protection)

Objective: Protect the carboxylic acid to prevent interference during reduction and coupling.

Reagents:

- **3-Bromo-5-nitrobenzoic acid** (10.0 g, 40.6 mmol)
- Methanol (100 mL, anhydrous)
- Sulfuric Acid (H₂SO₄, catalytic, 1.0 mL)

Protocol:

- **Dissolution:** In a 250 mL round-bottom flask equipped with a reflux condenser, dissolve 10.0 g of **3-Bromo-5-nitrobenzoic acid** in 100 mL of anhydrous methanol.
- **Catalysis:** Add 1.0 mL of concentrated H₂SO₄ dropwise with stirring.
- **Reflux:** Heat the mixture to reflux (65°C) for 6–8 hours. Monitor reaction progress via TLC (Hexane:Ethyl Acetate 7:3). The acid spot (R_f ~0.1) should disappear, replaced by the ester spot (R_f ~0.6).
- **Workup:** Cool to room temperature. Concentrate the solvent to ~20 mL under reduced pressure. Pour the residue into 100 mL ice-water.
- **Isolation:** The methyl ester will precipitate as a pale yellow solid. Filter, wash with cold water (2 x 20 mL), and dry in a vacuum oven at 45°C.
 - Yield: ~9.5 g (90-95%)
 - QC Check: ¹H NMR (CDCl₃) should show a singlet at ~3.9 ppm (OCH₃).

Step 2: Selective Nitro Reduction (The "Pivot" Step)

Objective: Reduce the nitro group to an amine WITHOUT de-halogenating the bromine.

Standard Pd/C hydrogenation is risky here as it often cleaves C-Br bonds.

Mechanism: Iron-mediated reduction (Béchamp conditions) is preferred for its chemoselectivity toward nitro groups in the presence of halogens.

Reagents:

- Methyl 3-bromo-5-nitrobenzoate (5.0 g, 19.2 mmol)
- Iron Powder (Fe, 325 mesh, 5.4 g, 5.0 equiv)
- Ammonium Chloride (NH₄Cl, 1.0 g)
- Ethanol/Water (4:1 mixture, 50 mL)

Protocol:

- Preparation: Suspend 5.0 g of the nitro-ester in 50 mL Ethanol/Water (4:1) in a 100 mL flask.
- Activation: Add 1.0 g NH₄Cl and 5.4 g Iron powder.
- Reaction: Heat to mild reflux (75–80°C) with vigorous stirring for 2–4 hours. The reaction color will shift from yellow to dark sludge (iron oxides).
- Filtration: Filter the hot mixture through a Celite pad to remove iron residues. Wash the pad with 20 mL hot ethanol.
- Concentration: Evaporate the filtrate to remove ethanol.
- Extraction: Extract the aqueous residue with Ethyl Acetate (3 x 30 mL). Dry the organic layer over Na₂SO₄ and concentrate.
 - Product: Methyl 3-amino-5-bromobenzoate (Off-white to brown solid).
 - Yield: ~3.8 g (85%).

- Purity Validation: HPLC >98%. This intermediate is stable and can be stored.

Step 3: Application - Synthesis of Benzamide Herbicides

Objective: Demonstrate the "Amide" pathway (Path 1) using a solvent-free thionyl chloride method, as validated by recent literature (Jagtap et al., 2019).

Protocol:

- Activation: Mix **3-Bromo-5-nitrobenzoic acid** (1.0 mmol) with Thionyl Chloride (SOCl₂, 1.5 mL) and a catalytic drop of DMF.
- Reflux: Heat at reflux for 2 hours until gas evolution (SO₂, HCl) ceases. Evaporate excess SOCl₂ under vacuum to obtain the acid chloride.
- Coupling: Add the crude acid chloride to a neat amine (e.g., tert-butylamine or 2,6-difluoroaniline) (1.2 mmol).
- Reaction: The reaction is exothermic. Stir for 10 minutes.
- Isolation: Quench with water. The benzamide precipitates immediately. Recrystallize from ethanol.

Analytical Data & Quality Control

To ensure protocol integrity, the following analytical parameters should be met for the key intermediate (Methyl 3-amino-5-bromobenzoate).

Parameter	Specification	Method
Appearance	Off-white to beige crystalline solid	Visual
Melting Point	78–82 °C	Capillary Method
HPLC Purity	> 98.0% (Area %)	C18 Column, ACN:H ₂ O (Gradient)
¹ H NMR (DMSO-d ₆)	δ 7.6 (s, 1H), 7.4 (s, 1H), 7.2 (s, 1H), 5.8 (s, 2H, NH ₂), 3.8 (s, 3H, OCH ₃)	400 MHz NMR
Mass Spec (ESI)	[M+H] ⁺ = 230.0/232.0 (Br isotope pattern)	LC-MS

Safety & Handling (SDS Summary)

- **3-Bromo-5-nitrobenzoic acid:** Irritant (Skin/Eye). May cause sensitization. Handle in a fume hood.
- Thionyl Chloride: Highly corrosive; reacts violently with water. Use strictly anhydrous conditions.
- Bromine Compounds: Organic bromides can be toxic; avoid inhalation of dusts.

References

- Jagtap, S. D., et al. (2019).[1] "Thionyl chloride induced convenient synthesis of benzamides from **3-bromo-5-nitrobenzoic acid** and amines under solvent free conditions." [1][2] Research Journal of Life Sciences, Bioinformatics, Pharmaceutical and Chemical Sciences.
- Ambeed. (2024). "Product Analysis: Methyl 3-bromo-5-nitrobenzoate." Chemical Data Sheet.
- BenchChem. (2024). "Synthesis pathways for **3-Bromo-5-nitrobenzoic acid** derivatives." Chemical Synthesis Database.

- Sigma-Aldrich. (2024). "3-Amino-5-bromobenzoic acid: Technical Specifications." Product Catalog.

Need Custom Synthesis?

BenchChem offers custom synthesis for rare earth carbides and specific isotopic labeling.

Email: info@benchchem.com or [Request Quote Online](#).

Sources

- [1. researchgate.net \[researchgate.net\]](#)
- [2. researchgate.net \[researchgate.net\]](#)
- To cite this document: BenchChem. [Application Note: Strategic Synthesis of Herbicides using 3-Bromo-5-nitrobenzoic Acid]. BenchChem, [2026]. [Online PDF]. Available at: [\[https://www.benchchem.com/product/b1267607/docs#application-note-strategic-synthesis-of-herbicides-using-3-bromo-5-nitrobenzoic-acid\]](https://www.benchchem.com/product/b1267607/docs#application-note-strategic-synthesis-of-herbicides-using-3-bromo-5-nitrobenzoic-acid)

Disclaimer & Data Validity:

The information provided in this document is for Research Use Only (RUO) and is strictly not intended for diagnostic or therapeutic procedures. While BenchChem strives to provide accurate protocols, we make no warranties, express or implied, regarding the fitness of this product for every specific experimental setup.

Technical Support: The protocols provided are for reference purposes. Unsure if this reagent suits your experiment?

Need Industrial/Bulk Grade? [Request Custom Synthesis Quote](#)

BenchChem

Our mission is to be the trusted global source of essential and advanced chemicals, empowering scientists and researchers to drive progress in science and industry.

Contact

Address: 3281 E Guasti Rd

Ontario, CA 91761, United States

Phone: (601) 213-4426

Email: info@benchchem.com

[Contact our Ph.D. Support Team for a compatibility check](#)