

A Technical Guide to 2-Amino-5-methylbenzotrile for Research Applications

Author: BenchChem Technical Support Team. **Date:** December 2025

Compound of Interest

Compound Name: 2-Amino-5-methylbenzotrile

Cat. No.: B1267719

[Get Quote](#)

For Researchers, Scientists, and Drug Development Professionals

This in-depth technical guide provides comprehensive information on **2-Amino-5-methylbenzotrile**, a key chemical intermediate in pharmaceutical research and development. This document outlines its commercial availability, physicochemical properties, and significant applications, with a focus on its role in the synthesis of targeted therapeutics. Detailed experimental protocols and visual diagrams of relevant biological pathways and analytical workflows are included to support its practical application in a research setting.

Commercial Availability and Supplier Specifications

2-Amino-5-methylbenzotrile (CAS No. 5925-93-9) is readily available from several commercial suppliers catering to the research and pharmaceutical industries. The purity and available quantities can vary between suppliers, and it is crucial for researchers to select a grade appropriate for their specific application. Below is a summary of typical product specifications from various vendors.

Supplier	Purity Specification	Available Quantities	Storage Conditions
Sigma-Aldrich	≥97%	Gram to multi-gram scale	2-8°C
ChemScene	≥98%	Milligram to gram scale	4°C, protect from light
Hangzhou Tianye Chemicals	≥98%	Gram to kilogram scale	2-8°C
Ningbo Inno Pharmchem	≥99.2% (HPLC)	Kilogram to multi-ton scale	2-8°C in a dry environment under inert atmosphere
Apollo Scientific	98%	Milligram to 100-gram scale	Room temperature, in a dark place, inert atmosphere
BLD Pharm	≥97%	Gram to kilogram scale	Room temperature, in a dark place, inert atmosphere
Thermo Scientific	97%	Gram scale	2-8°C

Physicochemical and Safety Data

A summary of the key physicochemical properties and safety information for **2-Amino-5-methylbenzotrile** is provided below.

Property	Value
CAS Number	5925-93-9
Molecular Formula	C ₈ H ₈ N ₂
Molecular Weight	132.16 g/mol [1]
Appearance	White to brown or off-white to pale yellow crystalline powder[2][3]
Melting Point	59-63 °C[4][5]
Solubility	Soluble in DMF and DMSO, partially soluble in ethanol[3]
SMILES	<chem>Nc1cc(C)ccc1C#N</chem>
Hazard Statements	H315 (Causes skin irritation), H319 (Causes serious eye irritation), H335 (May cause respiratory irritation)[6][7]
Precautionary Statements	P261, P264, P271, P280, P302+P352, P305+P351+P338[6]
Storage	Store in a well-ventilated place. Keep container tightly closed.[6]

Applications in Medicinal Chemistry: Synthesis of BTK Inhibitors

2-Amino-5-methylbenzotrile and its derivatives are valuable building blocks in the synthesis of heterocyclic compounds for medicinal chemistry.[8][9][10][11] A significant application of substituted aminobenzonitriles is in the preparation of Bruton's tyrosine kinase (BTK) inhibitors. BTK is a crucial enzyme in the B-cell receptor (BCR) signaling pathway and is a validated therapeutic target for B-cell malignancies and autoimmune diseases.[12] Second-generation BTK inhibitors, such as Acalabrutinib, have been developed to improve upon the selectivity and safety profile of the first-in-class drug, ibrutinib.

While a direct, publicly available synthesis protocol for a commercial drug starting specifically from **2-Amino-5-methylbenzotrile** is not readily found in the literature, the closely related analogue, 2-Amino-4-chloro-5-methylbenzotrile, is a key starting material in the synthesis of BTK inhibitors like Acalabrutinib and Zanubrutinib.[13] The following section provides a representative experimental protocol for a key transformation involving a substituted aminobenzotrile in the synthesis of a BTK inhibitor intermediate.

Bruton's Tyrosine Kinase (BTK) Signaling Pathway

The diagram below illustrates the central role of BTK in the B-cell receptor signaling pathway. Activation of the BCR by an antigen leads to the phosphorylation and activation of BTK, which in turn activates downstream signaling cascades, including the NF- κ B and MAPK pathways, promoting B-cell proliferation and survival. BTK inhibitors block this pathway by covalently binding to a cysteine residue in the active site of BTK.

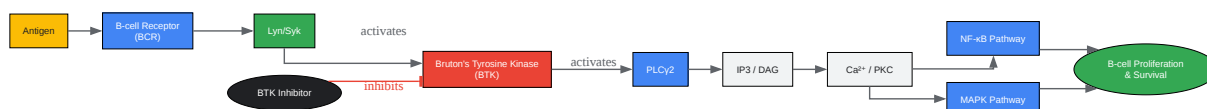

[Click to download full resolution via product page](#)

BTK Signaling Pathway

Experimental Protocols

Representative Synthesis of a Pyrimidine Intermediate for BTK Inhibitors

The following protocol is a representative example of how a substituted aminobenzotrile can be utilized in the synthesis of a core scaffold for BTK inhibitors. This multi-step synthesis illustrates the conversion of a 2,4-dichloropyrimidine to a key intermediate. While this specific example uses a different aminophenylcarbamate, the reaction principles are applicable to syntheses involving **2-Amino-5-methylbenzotrile** derivatives.

Reaction Scheme:

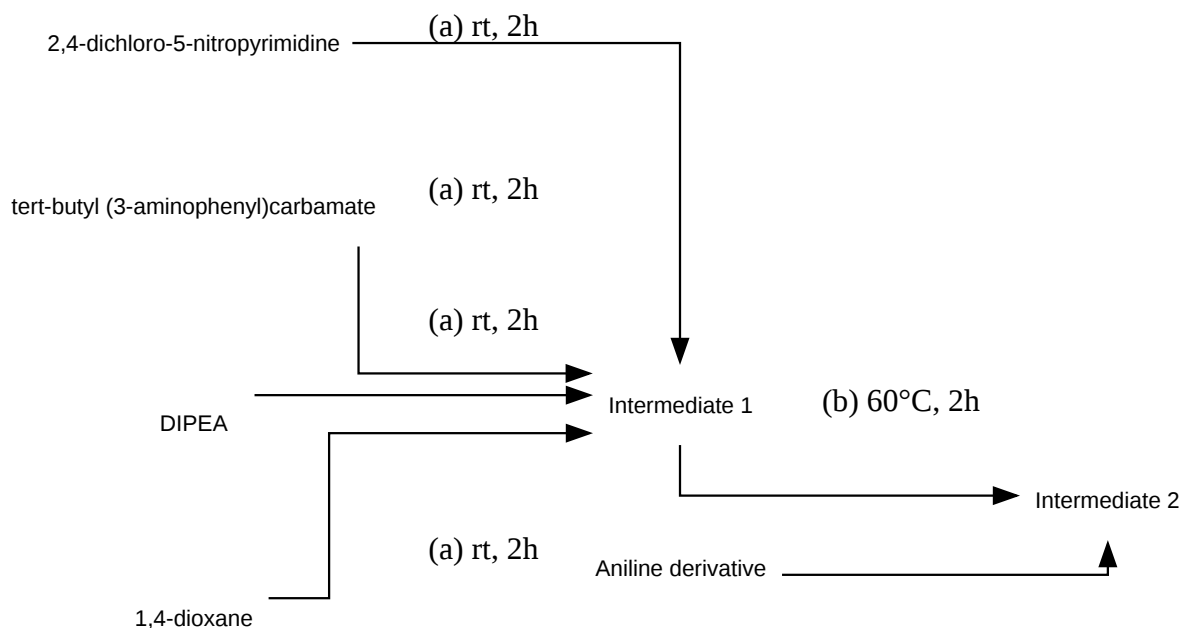

[Click to download full resolution via product page](#)

Synthesis of a Pyrimidine Intermediate

Step A: Synthesis of 2-chloro-4-(3-tert-butoxycarbonyl)phenylamino)-5-nitropyrimidine (Intermediate 1)

- To a solution of 2,4-dichloro-5-nitropyrimidine (1 equivalent) in 1,4-dioxane, add tert-butyl (3-aminophenyl)carbamate (1 equivalent).
- Add N,N-diisopropylethylamine (DIPEA) (1.5 equivalents) to the mixture.
- Stir the reaction mixture at room temperature for 2 hours.
- Monitor the reaction progress by Thin Layer Chromatography (TLC).
- Upon completion, quench the reaction with water and extract the product with ethyl acetate.

- Wash the organic layer with brine, dry over anhydrous sodium sulfate, and concentrate under reduced pressure.
- Purify the crude product by column chromatography on silica gel to afford Intermediate 1.

Step B: Synthesis of the Di-substituted Pyrimidine (Intermediate 2)

- To a solution of Intermediate 1 (1 equivalent) in 1,4-dioxane, add the desired aniline derivative (1.2 equivalents).
- Add DIPEA (1.5 equivalents) to the mixture.
- Heat the reaction mixture to 60°C and stir for 2 hours.
- Monitor the reaction by TLC.
- Upon completion, cool the reaction mixture to room temperature and concentrate under reduced pressure.
- Purify the residue by column chromatography to yield Intermediate 2.

Purity Determination by High-Performance Liquid Chromatography (HPLC)

The purity of **2-Amino-5-methylbenzotrile** and related synthetic intermediates is critical for their use in drug development. Reversed-phase HPLC (RP-HPLC) is a standard and reliable method for assessing the purity of such compounds. The following is a general protocol that can be adapted for the analysis of **2-Amino-5-methylbenzotrile**.

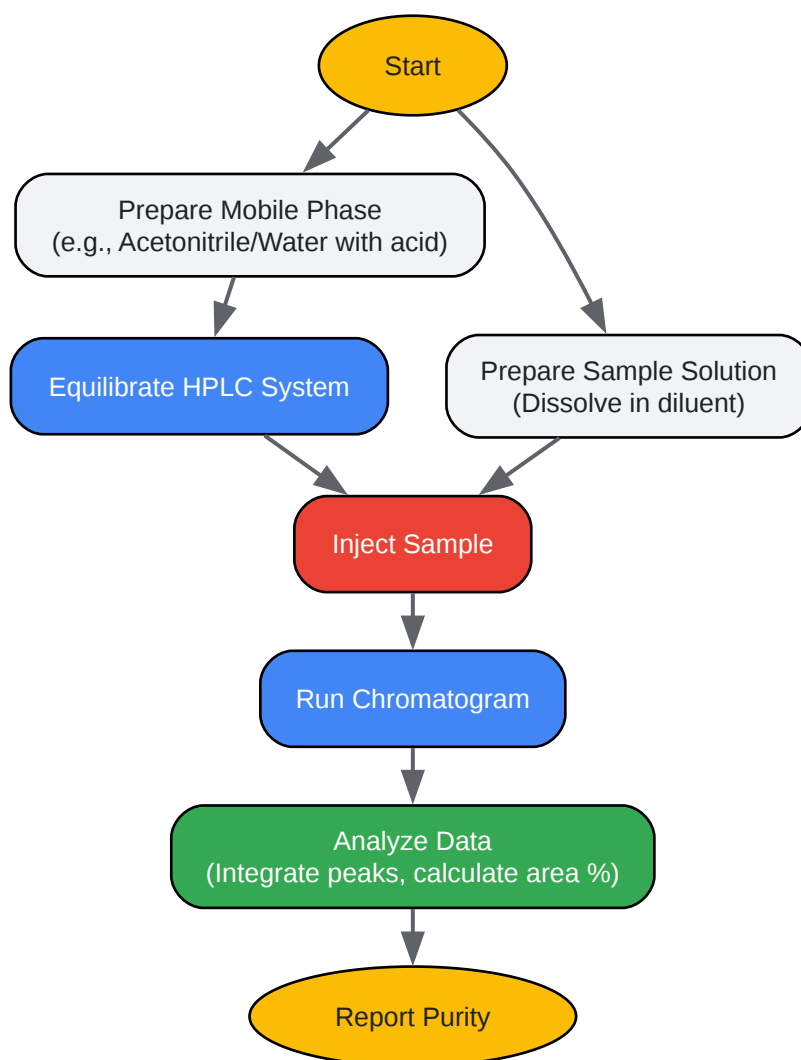

[Click to download full resolution via product page](#)

HPLC Purity Analysis Workflow

Instrumentation and Conditions:

- HPLC System: A standard HPLC system with a UV detector.
- Column: C18 reverse-phase column (e.g., 4.6 mm x 250 mm, 5 μ m).
- Mobile Phase: A gradient of acetonitrile and water, both containing 0.1% phosphoric acid or formic acid.
- Flow Rate: 1.0 mL/min.

- Detection: UV at an appropriate wavelength (e.g., 254 nm).
- Injection Volume: 10 μ L.

Procedure:

- Mobile Phase Preparation: Prepare the aqueous and organic mobile phases, filter, and degas them.
- Standard and Sample Preparation: Accurately weigh and dissolve the **2-Amino-5-methylbenzotrile** reference standard and test sample in a suitable diluent (e.g., acetonitrile/water mixture) to a known concentration (e.g., 1 mg/mL).
- System Equilibration: Equilibrate the HPLC system with the initial mobile phase composition until a stable baseline is achieved.
- Analysis: Inject the standard solution to determine the retention time and response, followed by the sample solution.
- Data Processing: Integrate the peaks in the chromatogram and calculate the purity of the sample using the area percent method.

This technical guide provides a foundational understanding of **2-Amino-5-methylbenzotrile** for its application in a research context. For specific synthetic procedures and analytical method development, further optimization based on the experimental setup and desired outcomes is recommended. Always consult the relevant Safety Data Sheet (SDS) before handling this chemical.

Need Custom Synthesis?

BenchChem offers custom synthesis for rare earth carbides and specific isotopic labeling.

Email: info@benchchem.com or [Request Quote Online](#).

References

- 1. A Comprehensive Review of Small-Molecule Inhibitors Targeting Bruton Tyrosine Kinase: Synthetic Approaches and Clinical Applications - PMC [pmc.ncbi.nlm.nih.gov]
- 2. researchgate.net [researchgate.net]
- 3. benchchem.com [benchchem.com]
- 4. researchgate.net [researchgate.net]
- 5. Targeting Bruton's Tyrosine Kinase in Inflammatory and Autoimmune Pathologies - PMC [pmc.ncbi.nlm.nih.gov]
- 6. researchgate.net [researchgate.net]
- 7. researchgate.net [researchgate.net]
- 8. Enaminonitrile in heterocyclic synthesis: synthesis and antimicrobial evaluation of some new pyrazole, isoxazole and pyrimidine derivatives incorporating a benzothiazole moiety - PubMed [pubmed.ncbi.nlm.nih.gov]
- 9. Heterocycles in Medicinal Chemistry - PMC [pmc.ncbi.nlm.nih.gov]
- 10. Frontiers | Aminoazole-Based Diversity-Oriented Synthesis of Heterocycles [frontiersin.org]
- 11. 5-Amino- and 6-amino-uracils in the synthesis of various heterocycles as therapeutic agents: a review - RSC Advances (RSC Publishing) [pubs.rsc.org]
- 12. WO2018191815A1 - Processes for the preparation of acalabrutinib and intermediates thereof - Google Patents [patents.google.com]
- 13. WO2020053795A2 - Process for the preparation of acalabrutinib and its intermediates - Google Patents [patents.google.com]
- To cite this document: BenchChem. [A Technical Guide to 2-Amino-5-methylbenzotrile for Research Applications]. BenchChem, [2025]. [Online PDF]. Available at: [https://www.benchchem.com/product/b1267719#commercial-suppliers-of-2-amino-5-methylbenzotrile-for-research]

Disclaimer & Data Validity:

The information provided in this document is for Research Use Only (RUO) and is strictly not intended for diagnostic or therapeutic procedures. While BenchChem strives to provide accurate protocols, we make no warranties, express or implied, regarding the fitness of this product for every specific experimental setup.

Technical Support: The protocols provided are for reference purposes. Unsure if this reagent suits your experiment? [[Contact our Ph.D. Support Team for a compatibility check](#)]

Need Industrial/Bulk Grade? [Request Custom Synthesis Quote](#)

BenchChem

Our mission is to be the trusted global source of essential and advanced chemicals, empowering scientists and researchers to drive progress in science and industry.

Contact

Address: 3281 E Guasti Rd
Ontario, CA 91761, United States
Phone: (601) 213-4426
Email: info@benchchem.com