

# Technical Support Center: Continuous-Flow Synthesis of Beta-Blockers

**Author:** BenchChem Technical Support Team. **Date:** December 2025

## Compound of Interest

Compound Name: 2-[(4-Bromophenoxy)methyl]oxirane

Cat. No.: B1266661

[Get Quote](#)

This technical support center provides researchers, scientists, and drug development professionals with comprehensive troubleshooting guides and frequently asked questions (FAQs) to address common challenges encountered during the continuous-flow synthesis of beta-blockers. Our goal is to help you improve conversion rates, optimize reaction conditions, and efficiently resolve experimental issues.

## Troubleshooting Guide

This guide is designed to help you diagnose and resolve common problems encountered during the continuous-flow synthesis of beta-blockers.

### Problem 1: Low Conversion or Yield

Possible Causes and Solutions:

- Inadequate Mixing: Poor mixing of reactants can lead to incomplete reactions.
  - Solution: Ensure your reactor setup includes an efficient micromixer. For reactions involving immiscible reagents, consider using a static mixer or a packed-bed reactor to enhance interfacial contact.
- Incorrect Stoichiometry: An improper molar ratio of reactants can limit the conversion of the limiting reagent.

- Solution: Carefully control the flow rates of your reactant streams to maintain the optimized molar ratio. For the synthesis of propranolol, for instance, increasing the isopropylamine equivalence can prevent the formation of undesired by-products and drive the reaction to completion.[1]
- Suboptimal Temperature: The reaction temperature may be too low for the reaction to proceed at a sufficient rate.
  - Solution: Gradually increase the temperature of the reactor. Continuous-flow systems allow for precise temperature control and can be operated at temperatures above the solvent's boiling point by using a back-pressure regulator.[2] For metoprolol synthesis, high-temperature (240 °C) and high-pressure (500 psi) conditions have been shown to achieve high yields with very short residence times.[2]
- Insufficient Residence Time: The reactants may not be spending enough time in the reactor to fully convert to the product.
  - Solution: Decrease the total flow rate or use a longer reactor coil to increase the residence time.
- Catalyst Deactivation: If using a heterogeneous catalyst, it may have become deactivated over time.
  - Solution: Regenerate or replace the catalyst. Consider using more robust catalysts, such as the amine-functionalized graphene oxide (NGO) membrane reactor, which has shown high stability and efficiency.[1][3]

## Problem 2: Reactor Clogging

Possible Causes and Solutions:

- Precipitation of Starting Materials, Intermediates, or Products: Solids forming within the narrow channels of a flow reactor is a common cause of clogging.
  - Solution 1: Solvent Selection: Choose a solvent system in which all components (reactants, intermediates, and products) are highly soluble at the reaction temperature.

- Solution 2: Temperature Adjustment: Increasing the reactor temperature can sometimes prevent precipitation.
- Solution 3: Sonication: Applying ultrasound to the reactor can help to break up solid particles and prevent them from agglomerating and causing blockages.
- Solution 4: Reactor Design: For reactions known to produce solids, consider using a continuous stirred-tank reactor (CSTR) system or a reactor with wider channels.
- Salt Formation: Inorganic salts formed as by-products can precipitate and block the reactor.
  - Solution: If possible, choose reagents that do not produce insoluble by-products. Alternatively, an in-line quenching and liquid-liquid extraction can be employed to remove salts from the reaction stream.

## Problem 3: Inconsistent Flow Rate or Pressure Fluctuations

Possible Causes and Solutions:

- Pump Issues:
  - Air Bubbles in the Pump: This can cause the pump to lose its prime and deliver an inconsistent flow.
    - Solution: Degas your solvents before use and ensure all connections on the suction side of the pump are airtight. Prime the pump carefully before starting the experiment.
  - Clogged Pump Inlet/Outlet: Particulate matter can block the pump's check valves.
    - Solution: Filter your reactant solutions before they enter the pump.
  - Worn Pump Seals: Leaking pump seals can lead to a loss of pressure and inconsistent flow.
    - Solution: Regularly inspect and replace pump seals as part of your preventative maintenance schedule.

- Back-Pressure Regulator (BPR) Malfunction: A faulty BPR can lead to pressure instability.
  - Solution: Ensure the BPR is clean and functioning correctly. Check for any blockages in the BPR or the downstream tubing.

## Problem 4: Formation of Impurities

Possible Causes and Solutions:

- Side Reactions: Undesired side reactions can lead to the formation of impurities, reducing the purity of the final product. A common issue in propranolol synthesis is the formation of a tertiary amine by-product.[4]
  - Solution 1: Temperature Optimization: Adjusting the reaction temperature can sometimes favor the desired reaction pathway over side reactions.
  - Solution 2: Additive Introduction: In the case of propranolol synthesis, the addition of a catalytic amount of water has been shown to significantly reduce the formation of the tertiary amine by-product and improve the purity of the desired product.[4]
  - Solution 3: Stoichiometry Control: Optimizing the molar ratio of reactants can minimize side reactions. For propranolol, a 1:3 molar ratio of naphthyl glycidyl ether to isopropylamine improves selectivity.[1]
- Degradation of Reagents or Products: Some compounds may be unstable under the reaction conditions.
  - Solution: Minimize the residence time at high temperatures. If a product is known to be unstable, consider an immediate in-line quench after it exits the reactor.

## Frequently Asked Questions (FAQs)

Q1: What are the main advantages of using continuous-flow synthesis for beta-blockers compared to traditional batch methods?

A1: Continuous-flow synthesis offers several key advantages, including:

- **Enhanced Safety:** Smaller reaction volumes minimize the risks associated with hazardous reactions and reagents.
- **Improved Heat and Mass Transfer:** The high surface-area-to-volume ratio in flow reactors allows for precise temperature control and efficient mixing, leading to faster reactions and fewer side products.
- **Higher Yields and Purity:** Optimized reaction conditions and reduced side reactions often result in higher yields and purer products.
- **Scalability:** Scaling up production is often simpler in flow chemistry by either running the system for longer (scaling out) or by using multiple reactors in parallel (numbering up).
- **Automation:** Continuous-flow systems can be easily automated for unattended operation and data logging.

Q2: How can I monitor the progress of my reaction in real-time?

A2: Integrating in-line analytical techniques, also known as Process Analytical Technology (PAT), is crucial for real-time reaction monitoring. Common methods include:

- **Spectroscopy:** UV/Vis, Infrared (IR), and Raman spectroscopy can provide real-time information on the concentration of reactants and products.<sup>[5][6]</sup>
- **Nuclear Magnetic Resonance (NMR):** Flow NMR spectroscopy is a powerful tool for detailed structural analysis and reaction kinetics.<sup>[5]</sup>
- **Chromatography:** In-line High-Performance Liquid Chromatography (HPLC) or Ultra-High-Performance Liquid Chromatography (UHPLC) can be used for automated sampling and analysis of the reaction mixture.<sup>[5]</sup>

Q3: What type of reactor is best suited for beta-blocker synthesis?

A3: The choice of reactor depends on the specific reaction.

- **Coil Reactors (PFRs):** These are the most common type of flow reactors and are suitable for many homogeneous reactions.

- Packed-Bed Reactors: These are useful for reactions involving solid catalysts or reagents.
- Microreactors: These offer excellent heat and mass transfer but can be prone to clogging.
- Membrane Reactors: Novel systems like the amine-functionalized graphene oxide (NGO) membrane reactor have shown exceptional performance for propranolol synthesis, achieving nearly 100% conversion in seconds at room temperature.<sup>[1][3]</sup>

Q4: Can I use continuous-flow for chiral synthesis of beta-blockers?

A4: Yes, continuous-flow systems are well-suited for asymmetric synthesis. This can be achieved by using chiral catalysts in a packed-bed reactor or by employing biocatalysis with immobilized enzymes.

## Data Presentation: Comparison of Continuous-Flow Synthesis Methods for Beta-Blockers

Beta-Blocker	Method	Key Parameters	Conversion/Yield	Reference
Propranolol	Amine-functionalized graphene oxide (NGO) membrane reactor	Temperature: 23 °C; Reactant Molar Ratio (naphthyl glycidyl ether:isopropylamine): 1:3	Nearly 100% conversion and selectivity in < 4.63 seconds	[1]
Propranolol	Addition of catalytic water	Addition of a catalytic amount of water to the isopropylamine stream	90% yield with 94% HPLC purity, reducing tertiary amine byproduct to 6%	[4]
Metoprolol	High-Temperature/High-Pressure	Temperature: 240 °C; Pressure: 500 psi	91% yield	[2][4]
Atenolol	One-pot synthesis in Deep Eutectic Solvent (DES)	Temperature: 40 °C; Solvent: Choline chloride:ethylene glycol (ChCl:EG)	95% overall yield	[7]

## Experimental Protocols

### Key Experiment 1: Continuous-Flow Synthesis of Propranolol using an NGO Membrane Reactor

Objective: To achieve high conversion and selectivity in the synthesis of propranolol under mild conditions.

Materials:

- 1-Naphthol

- Epichlorohydrin
- Isopropylamine
- Amine-functionalized graphene oxide (NGO) membrane
- Vacuum-assisted filtration setup
- Continuous-flow reactor system with precision pumps

#### Methodology:

- Prepare the Intermediate (Naphthyl Glycidyl Ether): Synthesize naphthyl glycidyl ether from 1-naphthol and epichlorohydrin according to established batch procedures.
- Assemble the NGO Membrane Reactor: Fabricate the NGO membrane using vacuum-assisted filtration. Install the membrane into a suitable module within the continuous-flow setup.
- Prepare Reactant Solutions: Prepare a solution of naphthyl glycidyl ether in a suitable solvent and a separate solution of isopropylamine.
- Set Up the Flow System:
  - Use two separate pumps to deliver the naphthyl glycidyl ether solution and the isopropylamine solution.
  - Set the flow rates to achieve a 1:3 molar ratio of naphthyl glycidyl ether to isopropylamine.
  - The combined stream is then passed through the NGO membrane reactor.
- Reaction Conditions:
  - Maintain the reactor temperature at 23 °C.
  - The residence time within the membrane reactor is typically less than 5 seconds.



- **Collection and Analysis:** Collect the product stream exiting the reactor. Analyze the product for conversion and selectivity using HPLC or GC-MS.

## Key Experiment 2: Continuous-Flow Synthesis of Atenolol in a Deep Eutectic Solvent

Objective: To perform a sustainable, one-pot synthesis of atenolol with high yield.

Materials:

- 2-(4-hydroxyphenyl)acetamide
- Epichlorohydrin
- Isopropylamine
- Choline chloride (ChCl)
- Ethylene glycol (EG)
- Continuous-flow reactor system with a heated coil reactor

Methodology:

- **Prepare the Deep Eutectic Solvent (DES):** Mix choline chloride and ethylene glycol in a 1:2 molar ratio and heat gently until a clear, homogeneous liquid is formed.
- **Prepare Reactant Feed:** Dissolve 2-(4-hydroxyphenyl)acetamide in the ChCl:EG DES.
- **Set Up the Two-Step Flow System:**
  - **Step 1: Epoxidation:**
    - Pump the solution of 2-(4-hydroxyphenyl)acetamide in DES and a separate stream of epichlorohydrin (1.5 equivalents) into a T-mixer.
    - Pass the mixed stream through a heated coil reactor at 40 °C with a residence time of 6 hours.

- Step 2: Amination:
  - Introduce a stream of isopropylamine (3 equivalents) to the output of the first reactor using another T-mixer.
  - Pass the new mixture through a second heated coil reactor at 40 °C with a residence time of 6 hours.
- Work-up and Isolation:
  - Collect the product stream.
  - Remove excess isopropylamine under vacuum.
  - Add water to precipitate the atenolol product.
  - Filter, wash with water, and dry the solid to obtain pure atenolol.

## Visualizations

### Experimental Workflow for Continuous-Flow Synthesis of Beta-Blockers

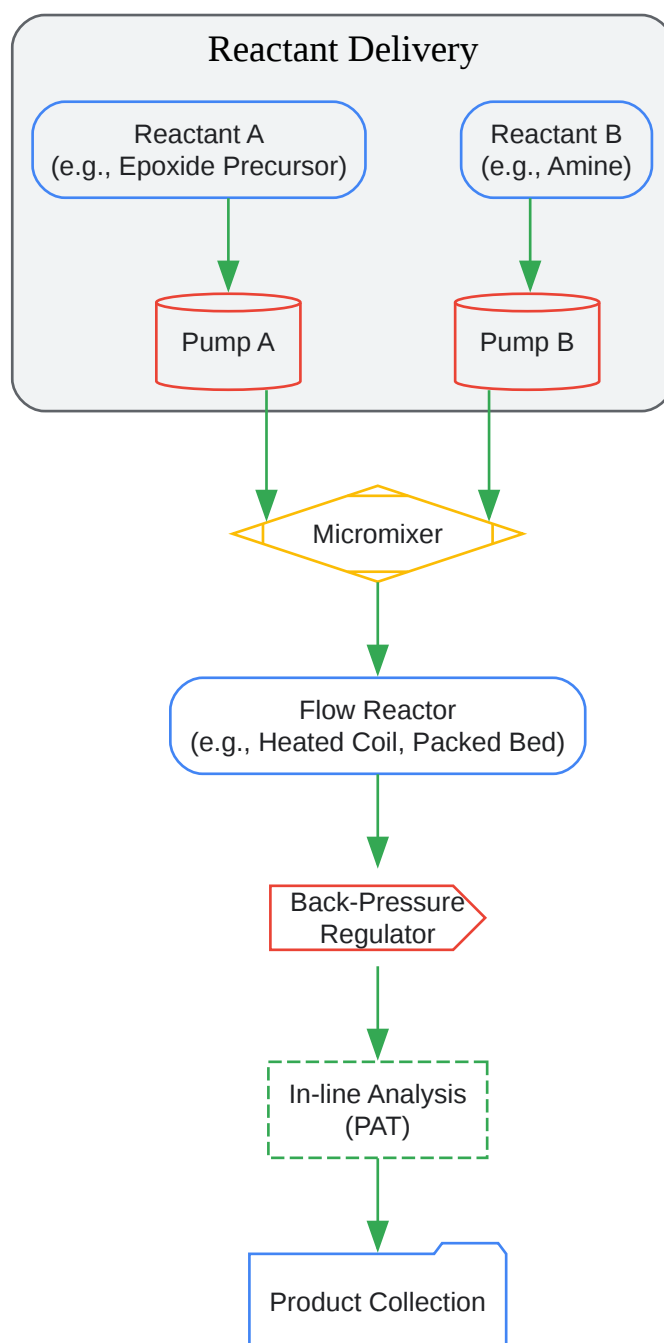

[Click to download full resolution via product page](#)

Caption: A generalized workflow for the continuous-flow synthesis of beta-blockers.

## Troubleshooting Logic for Low Conversion

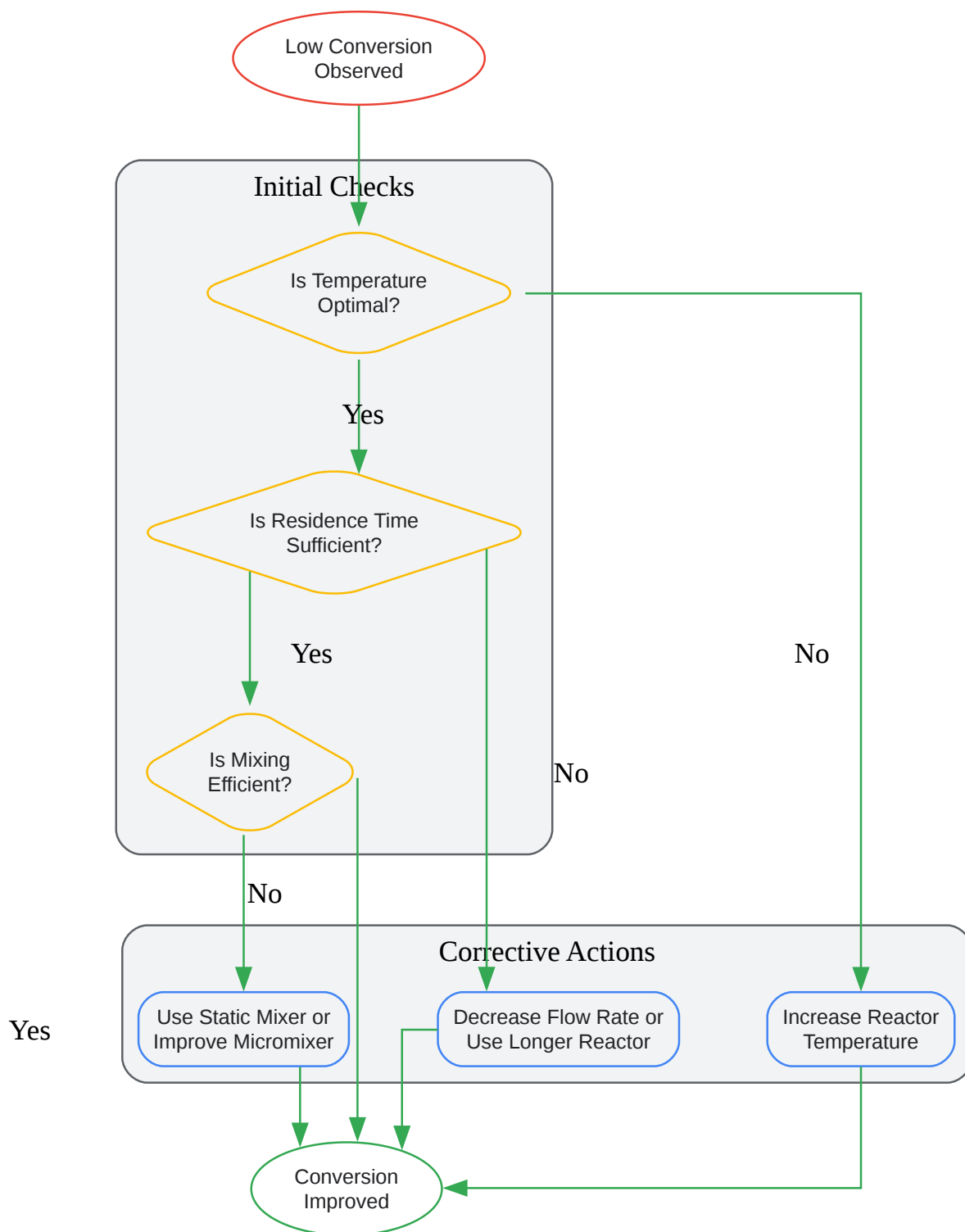

[Click to download full resolution via product page](#)

Caption: A decision tree for troubleshooting low conversion in continuous-flow synthesis.

**Need Custom Synthesis?**

BenchChem offers custom synthesis for rare earth carbides and specific isotopic labeling.

Email: [info@benchchem.com](mailto:info@benchchem.com) or [Request Quote Online](#).

## References

- 1. europeanpharmaceuticalreview.com [europeanpharmaceuticalreview.com]
- 2. scielo.br [scielo.br]
- 3. bioengineer.org [bioengineer.org]
- 4. scribd.com [scribd.com]
- 5. researchgate.net [researchgate.net]
- 6. Real-time Monitoring of Reactions Performed Using Continuous-flow Processing: The Preparation of 3-Acetylcoumarin as an Example - PMC [pmc.ncbi.nlm.nih.gov]
- 7. Sustainable Synthesis of the Active Pharmaceutical Ingredient Atenolol in Deep Eutectic Solvents - PMC [pmc.ncbi.nlm.nih.gov]
- To cite this document: BenchChem. [Technical Support Center: Continuous-Flow Synthesis of Beta-Blockers]. BenchChem, [2025]. [Online PDF]. Available at: [https://www.benchchem.com/product/b1266661#continuous-flow-synthesis-of-beta-blockers-to-improve-conversion]

---

**Disclaimer & Data Validity:**

The information provided in this document is for Research Use Only (RUO) and is strictly not intended for diagnostic or therapeutic procedures. While BenchChem strives to provide accurate protocols, we make no warranties, express or implied, regarding the fitness of this product for every specific experimental setup.

**Technical Support:** The protocols provided are for reference purposes. Unsure if this reagent suits your experiment? [[Contact our Ph.D. Support Team for a compatibility check](#)]

**Need Industrial/Bulk Grade?** [Request Custom Synthesis Quote](#)

# BenchChem

Our mission is to be the trusted global source of essential and advanced chemicals, empowering scientists and researchers to drive progress in science and industry.

## Contact

Address: 3281 E Guasti Rd

Ontario, CA 91761, United States

Phone: (601) 213-4426

Email: [info@benchchem.com](mailto:info@benchchem.com)