

Technical Support Center: Characterization of 2,5,8-Trimethylquinolin-4-ol

Author: BenchChem Technical Support Team. **Date:** May 2026

Compound of Interest

Compound Name: 2,5,8-Trimethylquinolin-4-ol

CAS No.: 54598-17-3

Cat. No.: B1266977

[Get Quote](#)

Executive Summary

Researchers characterizing **2,5,8-Trimethylquinolin-4-ol** frequently encounter data that contradicts predicted models. The three primary sources of error are:

- The Tautomerism Trap: Misidentification of the dominant 4-quinolone tautomer as an impurity or degradation product due to the absence of "expected" hydroxyl signals.
- The Knorr-Conrad-Limpach Divergence: Inadvertent synthesis of the constitutional isomer (4,5,8-trimethylquinolin-2-ol) due to thermal control failures during the condensation step.
- Solubility-Induced Artifacts: Poor spectral resolution caused by aggregation in non-polar solvents.

Module 1: The Isomer Divergence (Synthesis Troubleshooting)

Problem: "My product has the correct mass (m/z 187) but the NMR fingerprint does not match the reference standard."

Root Cause: You may have synthesized the Knorr product (2-quinolone) instead of the Conrad-Limpach product (4-quinolone). Both pathways use the same starting materials (2,5-dimethylaniline and ethyl acetoacetate) but diverge based on the initial condensation temperature. The kinetic pathway (Conrad-Limpach) requires low-temperature imine formation followed by high-temperature cyclization. The thermodynamic pathway (Knorr) proceeds via an amide intermediate.

Diagnostic Workflow

Use this comparative analysis to determine which isomer you have isolated.

Feature	Target: 2,5,8-Trimethylquinolin-4-ol	Impurity: 4,5,8-Trimethylquinolin-2-ol
Synthesis Path	Conrad-Limpach (Imine Intermediate)	Knorr (Anilide Intermediate)
Key Mechanism	Cyclization of beta-aminoacrylate	Cyclization of beta-ketoanilide
Sterics	Minor Peri-Interaction: C4=O vs C5-Me	Severe Peri-Interaction: C4-Me vs C5-Me
¹ H NMR (C3-H)	Singlet, typically ~6.0 ppm	Singlet, typically ~6.5 ppm
¹ H NMR (Methyls)	C2-Me (Singlet)	C4-Me (Singlet)
NOE Signal	Strong NOE: C2-Me ↔ NHNo NOE: C2-Me ↔ C5-Me	Strong NOE: C4-Me ↔ C5-Me (Diagnostic!)
¹³ C NMR (C=O)	C4 Carbonyl: ~177 ppm	C2 Carbonyl: ~162 ppm

Visualization: Reaction Pathway Divergence

The following diagram illustrates the critical bifurcation point in the synthesis.

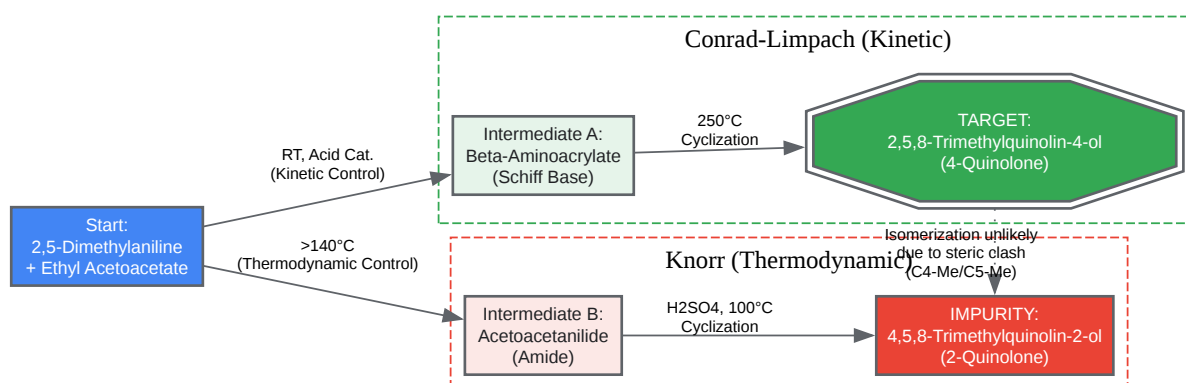

[Click to download full resolution via product page](#)

Caption: Bifurcation of quinoline synthesis. Low-temperature condensation favors the Target (Green); high-temperature condensation favors the Impurity (Red).

Module 2: The Tautomerism Trap (Spectral Interpretation)

Problem: "The IR spectrum shows a strong Carbonyl peak (1630 cm^{-1}), and NMR shows no O-H peak. Did I synthesize the ketone derivative instead?"

Technical Explanation: You have synthesized the correct compound, but the name "Quinolin-4-ol" is misleading. In the solid state and polar solvents (DMSO, MeOH), the equilibrium lies almost exclusively towards the 4-Quinolone (oxo) tautomer, not the 4-Hydroxy (enol) form.

- Aromaticity vs. Stability: While the enol form restores pyridine ring aromaticity, the oxo form benefits from a high resonance stabilization energy of the vinylogous amide system.
- The "Missing" Proton: The proton resides on the Nitrogen (N-H), not the Oxygen. In ¹H NMR (DMSO-d₆), look for a broad singlet downfield (11.0–12.0 ppm), which is the N-H.

Comparison of Spectral Features

Spectral Method	Observation (Quinolone Form)	Interpretation
IR Spectroscopy	Strong band at 1620–1640 cm^{-1}	C=O Stretching (Vinylogous Amide). Not an impurity.
^1H NMR	Broad singlet >11 ppm	N-H Proton (Exchangeable with D_2O).
^1H NMR	Absence of sharp singlet at ~ 9 - 10 ppm	Absence of Phenolic O-H.
UV-Vis	Bathochromic shift in polar solvents	Stabilization of the dipolar zwitterionic resonance form.

Module 3: Solubility & Sample Preparation

Problem: "The sample precipitates in CDCl_3 or gives broad, unreadable peaks."

Solution: **2,5,8-Trimethylquinolin-4-ol** exhibits strong intermolecular hydrogen bonding (Head-to-Tail dimerization) in the solid state, leading to high lattice energy and poor solubility in non-polar solvents.

Recommended Protocol:

- Primary Solvent: DMSO- d_6 . This disrupts the intermolecular H-bonds, yielding sharp peaks.
- Alternative: TFA- d (Trifluoroacetic acid- d). If DMSO fails, TFA will protonate the carbonyl/nitrogen, solubilizing the compound completely. Note: This will shift peaks downfield significantly.
- Avoid: CDCl_3 , Acetone- d_6 , or Benzene- d_6 . These promote aggregation/stacking, resulting in line broadening and loss of splitting information.

Solubility Troubleshooting Matrix

Solvent	Solubility Rating	NMR Quality	Use Case
Chloroform (CDCl ₃)	Poor	Broad/Missing	Do Not Use. Aggregation artifacts.
Methanol (MeOD)	Moderate	Good	Routine purity checks (beware of H/D exchange).
DMSO-d ₆	Excellent	High Resolution	Standard Characterization.
TFA-d	Excellent	Sharp (Shifted)	For highly crystalline/stubborn samples.

References

- Conrad, M., & Limpach, L. (1887).[1] Über das Synthesen von Chinolinderivaten. Berichte der deutschen chemischen Gesellschaft.
- Riegel, B., et al. (1946). The Synthesis of some 4-Quinolinols and 4-Chloroquinolines by the Conrad-Limpach Method. Journal of the American Chemical Society.
- Gould, S. J., & Jacobs, W. A. (1939). The Synthesis of Certain Substituted Quinolines and 5,6-Benzoquinolines. Journal of the American Chemical Society.
- Reuman, M., & Meyers, A. I. (1985). The Synthetic Utility of 4-Quinolones. Tetrahedron.
- PubChem Compound Summary. (2023). **2,5,8-trimethylquinolin-4-ol**.[2] National Center for Biotechnology Information.

Need Custom Synthesis?

BenchChem offers custom synthesis for rare earth carbides and specific isotopic labeling.

Email: info@benchchem.com or [Request Quote Online](#).

Sources

- [1. scribd.com \[scribd.com\]](https://www.scribd.com)
- [2. PubChemLite - 2,5,8-trimethylquinolin-4-ol \(C12H13NO\) \[pubchemlite.lcsb.uni.lu\]](https://pubchemlite.lcsb.uni.lu)
- To cite this document: BenchChem. [Technical Support Center: Characterization of 2,5,8-Trimethylquinolin-4-ol]. BenchChem, [2026]. [Online PDF]. Available at: [\[https://www.benchchem.com/product/b1266977/docs#technical-support-center-characterization-of-2-5-8-trimethylquinolin-4-ol\]](https://www.benchchem.com/product/b1266977/docs#technical-support-center-characterization-of-2-5-8-trimethylquinolin-4-ol)

Disclaimer & Data Validity:

The information provided in this document is for Research Use Only (RUO) and is strictly not intended for diagnostic or therapeutic procedures. While BenchChem strives to provide accurate protocols, we make no warranties, express or implied, regarding the fitness of this product for every specific experimental setup.

Technical Support: The protocols provided are for reference purposes. Unsure if this reagent suits your experiment?

Need Industrial/Bulk Grade? [Request Custom Synthesis Quote](#)

BenchChem

Our mission is to be the trusted global source of essential and advanced chemicals, empowering scientists and researchers to drive progress in science and industry.

Contact

Address: 3281 E Guasti Rd
Ontario, CA 91761, United States
Phone: (601) 213-4426
Email: info@benchchem.com

[Contact our Ph.D. Support Team for a compatibility check](#)

