

# Introduction: The Enduring Significance of Thiophene in Organic Electronics

**Author:** BenchChem Technical Support Team. **Date:** May 2026

## Compound of Interest

Compound Name:	3-bromo-2,5-dithiophen-2-ylthiophene
CAS No.:	105125-00-6
Cat. No.:	B1266009

[Get Quote](#)

Thiophene and its derivatives represent a cornerstone in the field of organic electronics, particularly for Organic Field-Effect Transistors (OFETs). Their enduring appeal stems from a unique combination of electronic properties, chemical versatility, and processability.[1][2] The sulfur heteroatom in the thiophene ring contributes to strong intermolecular interactions, which are crucial for efficient charge transport, while the  $\pi$ -conjugated backbone provides the pathway for charge carrier movement.[2] The ability to chemically modify the thiophene backbone—by extending conjugation length, introducing functional side chains, or fusing rings—allows for precise tuning of the material's electronic and physical properties.[3][4] This guide provides a comparative analysis of OFETs based on different classes of thiophene derivatives, grounded in experimental data, to elucidate the critical structure-property relationships that govern device performance.

## The Critical Role of Molecular Structure in Device Performance

The performance of a thiophene-based OFET is not determined by a single parameter but is a result of a complex interplay between the intrinsic electronic properties of the molecule and the

collective organization of these molecules in a thin film. The molecular structure is the primary determinant of both.

## From Oligomers to Polymers: The Impact of Conjugation Length

The length of the  $\pi$ -conjugated system is a fundamental parameter.

- **Oligothiophenes:** These are short, well-defined chains of thiophene units (typically 2-6 rings). [5] Their precise structure allows for the formation of highly crystalline films, which serve as excellent models for studying charge transport. [4] However, their performance can be limited by grain boundaries in polycrystalline films. Increasing the number of thiophene units generally increases charge carrier mobility but can reduce solubility. [3]
- **Polythiophenes:** Polymers like the benchmark material Poly(3-hexylthiophene) (P3HT) offer excellent solution processability and the ability to form large-area films. [6][7] Performance is highly dependent on the polymer's regioregularity—the consistency of side-chain attachment—which dictates the planarity of the backbone and the efficiency of intermolecular  $\pi$ - $\pi$  stacking. [8] While offering good performance, the polydispersity of polymers can lead to a higher degree of energetic disorder compared to oligomers.

## Side-Chain Engineering: The Key to Processability and Stability

Side chains, typically alkyl groups, are appended to the thiophene backbone primarily to impart solubility in common organic solvents, enabling solution-based fabrication techniques. [8]

However, their role is far more nuanced:

- **Alkyl Chains:** The length and branching of alkyl chains influence molecular packing. Linear chains can promote ordered, edge-on packing beneficial for charge transport, whereas branched chains might disrupt this order but improve solubility. [9]
- **Functional Groups:** Incorporating specific functional groups can alter electronic properties and stability. Ester-functionalized polythiophenes, for example, have shown enhanced air stability due to lower HOMO levels. [10] Conversely, hydrophilic side chains like oligoethylene

glycol (OEG) can lead to charge trapping and device degradation due to their interaction with ambient moisture.[11]

## Fused Thiophenes: Enforcing Planarity for High Mobility

To overcome the rotational freedom of single bonds between thiophene units, researchers have developed fused-ring systems like dithieno[3,2-b:2',3'-d]thiophene (DTT).[12][13] Fusing the rings creates a rigid, planar backbone. This enforced planarity enhances  $\pi$ -orbital overlap and promotes strong intermolecular packing, leading to some of the highest reported mobilities for thiophene-based materials.[14][15]

Below is a diagram illustrating the structural differences between these key classes of thiophene derivatives.

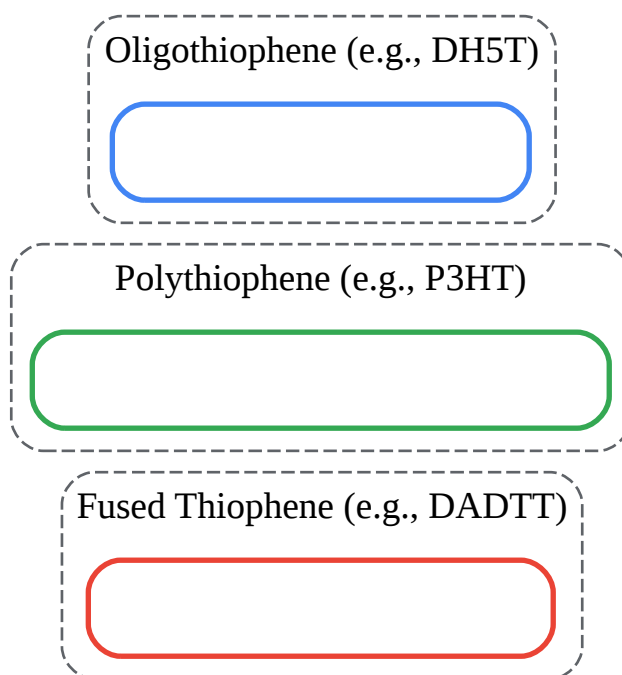

[Click to download full resolution via product page](#)

Caption: Key classes of thiophene-based semiconductors for OFETs.

## Comparative Performance Analysis

The performance of an OFET is quantified by several key metrics: charge carrier mobility ( $\mu$ ), the on/off current ratio ( $I_{on}/I_{off}$ ), and threshold voltage ( $V_{th}$ ). The table below summarizes experimental data for representative thiophene derivatives, highlighting the impact of molecular structure and fabrication method.

Semiconductor Material	Class	Fabrication Method	Mobility ( $\mu$ ) [cm <sup>2</sup> /Vs]	On/Off Ratio (Ion/Ioff)	Key Findings & Reference
P3HT (regioregular)	Polythiophene	Solution-Processed	~0.1	10 <sup>4</sup>	A benchmark polymer; performance is highly sensitive to processing conditions.[6]
Ester-functionalized Polythiophene	Polythiophene	Solution-Processed	3.3 x 10 <sup>-3</sup>	> 10 <sup>3</sup>	Exhibits significantly improved air stability compared to P3HT.[10]
DHFTTF (Oligofluorene-thiophene)	Oligomer	Vacuum-Evaporated	0.12	10 <sup>5</sup>	Combines high mobility with remarkable stability in air. [16]
Thieno[2,3-b]thiophene derivative	Fused Thiophene	Solution-Sheared	0.42	> 10 <sup>8</sup>	Linear alkyl chains enhance molecular packing and performance. [9]
2,6-DADTT (Dithieno[3,2-b:2',3'-d]thiophene derivative)	Fused Thiophene	Single Crystal	1.26	10 <sup>6</sup> - 10 <sup>8</sup>	Excellent performance attributed to dense herringbone packing in a

						single crystal. [12][17]
BPy2T (Pyrene end- capped oligothiophen e)	Oligomer	Single Crystal	3.3	-		Rigid pyrene core promotes strong $\pi$ - $\pi$ stacking.[17]
TT-BT Copolymer	Copolymer	Solution- Processed	0.1	$3.5 \times 10^3$		A donor- acceptor copolymer that operates at low voltage ( $< -3$ V).[18]

## Fabrication and Characterization: From Molecule to Device

The transition from a promising molecule to a high-performing device is critically dependent on the fabrication process, which dictates the morphology of the semiconductor thin film.

### Device Architecture

The most common device structure is the bottom-gate, top-contact (BGTC) architecture. In this configuration, the gate electrode and dielectric layer are prepared first, followed by the deposition of the organic semiconductor, and finally the source and drain electrodes. This structure generally provides a good semiconductor/dielectric interface and reliable performance.[2]

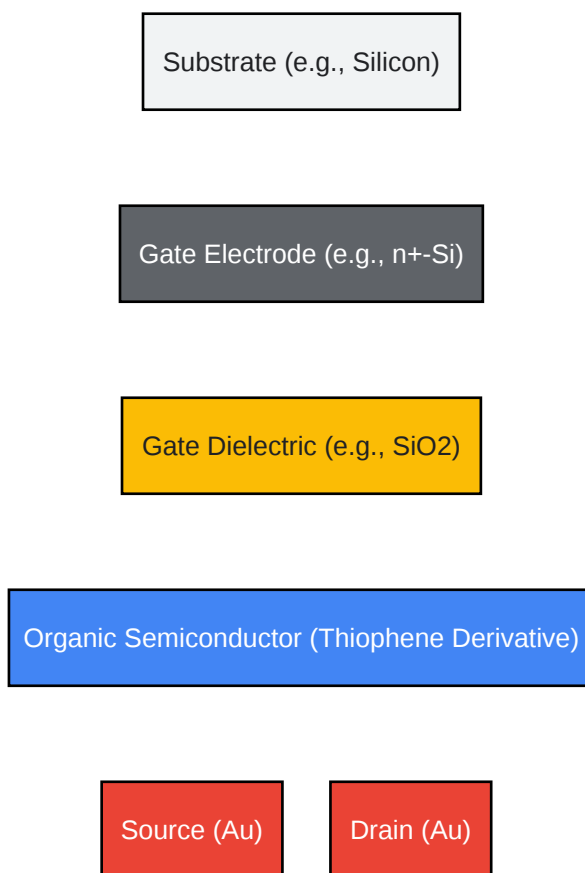

[Click to download full resolution via product page](#)

Caption: Schematic of a bottom-gate, top-contact (BGTC) OFET.

## Solution Processing vs. Vacuum Deposition

- **Solution Processing:** Techniques like spin-coating, drop-casting, and solution-shearing are attractive for large-area, low-cost manufacturing.[19][20] They are particularly suitable for soluble polymers and functionalized oligomers. The final film morphology depends on the choice of solvent, deposition speed, and substrate temperature.[19]
- **Vacuum Thermal Evaporation:** This technique is primarily used for small molecules and oligomers that can be sublimed without decomposition. It allows for precise control over film thickness and can produce highly ordered crystalline films, though it is generally a more complex and expensive process.[2][16]

## Experimental Protocols

Reproducibility is paramount in scientific research. The following section provides a representative protocol for the fabrication and characterization of a solution-processed P3HT-based OFET.

## Protocol 1: Fabrication of a P3HT-Based OFET (BGTC)

This protocol outlines a standard procedure for creating a bottom-gate, top-contact OFET on a silicon wafer.

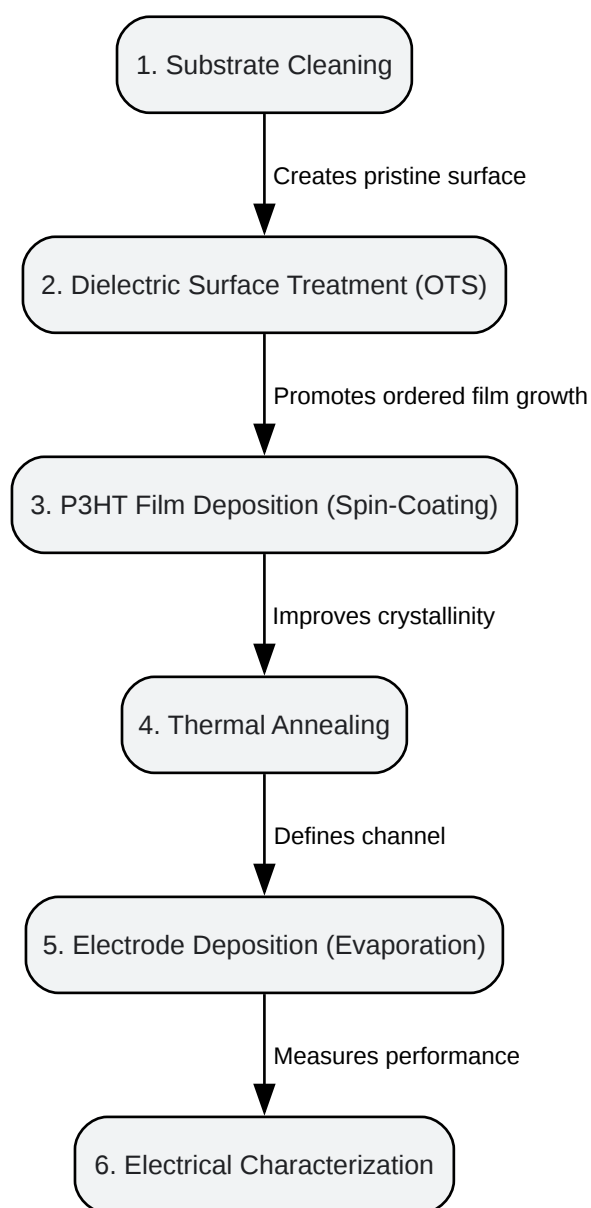

[Click to download full resolution via product page](#)

Caption: Workflow for fabricating and testing a P3HT OFET.

#### Step-by-Step Methodology:

- Substrate Preparation:
  - Begin with a heavily n-doped silicon wafer with a 300 nm thermally grown silicon dioxide (SiO<sub>2</sub>) layer. The doped silicon acts as the gate electrode, and the SiO<sub>2</sub> serves as the gate dielectric.
  - Clean the substrate by sonicating sequentially in acetone, and isopropyl alcohol for 15 minutes each.
  - Dry the substrate under a stream of nitrogen gas and bake at 120°C for 10 minutes to remove residual moisture.
  - Causality: This rigorous cleaning is essential to remove organic and particulate contaminants, ensuring a pristine dielectric surface for subsequent layers.
- Dielectric Surface Modification:
  - Treat the SiO<sub>2</sub> surface with an octadecyltrichlorosilane (OTS) self-assembled monolayer (SAM). Place the cleaned substrates in a vacuum desiccator along with a small vial containing a few drops of OTS.
  - Hold the desiccator under vacuum for 12 hours.
  - Causality: The OTS treatment transforms the hydrophilic SiO<sub>2</sub> surface into a hydrophobic one. This reduces charge trapping at the dielectric-semiconductor interface and promotes the favorable edge-on packing of P3HT molecules, which is crucial for efficient in-plane charge transport.[\[21\]](#)
- Semiconductor Deposition:
  - Prepare a solution of regioregular P3HT in a high-boiling-point solvent like chlorobenzene or TCB at a concentration of 5 mg/mL.
  - Spin-coat the P3HT solution onto the OTS-treated substrate at 2000 rpm for 60 seconds.

- Causality: Spin-coating allows for the formation of a uniform thin film. The choice of solvent and spin speed controls the film thickness and drying rate, which influences the degree of polymer chain ordering.
- Thermal Annealing:
  - Anneal the P3HT film on a hotplate at 120°C for 20 minutes in a nitrogen-filled glovebox.
  - Causality: Annealing above the glass transition temperature of P3HT provides the polymer chains with sufficient thermal energy to rearrange into more ordered, crystalline domains, thereby reducing structural defects and improving charge carrier mobility.
- Electrode Deposition:
  - Deposit 50 nm thick gold source and drain electrodes onto the P3HT film using thermal evaporation through a shadow mask. The shadow mask defines the channel length (L) and width (W) of the transistor.
  - Causality: Gold is used due to its high work function, which facilitates efficient hole injection into the HOMO level of P3HT, and its inertness. The top-contact configuration avoids potential damage to the organic layer that can occur in bottom-contact fabrication. [\[2\]](#)
- Electrical Characterization:
  - Perform all electrical measurements in an inert atmosphere (e.g., a glovebox) using a semiconductor parameter analyzer.
  - Measure the output characteristics (IDS vs. VDS at various VGS) and transfer characteristics (IDS vs. VGS at a fixed VDS).
  - Extract the field-effect mobility and on/off ratio from the transfer characteristics in the saturation regime.
  - Causality: Characterization in an inert environment is critical to prevent degradation of the semiconductor by oxygen and moisture, which can act as charge traps and dopants, leading to inaccurate performance metrics.[\[22\]](#)

## Conclusion and Future Outlook

The performance of OFETs based on thiophene derivatives has seen remarkable progress, with mobilities now exceeding those of amorphous silicon. This advancement is a direct result of rational molecular design, where control over conjugation, planarity, and intermolecular packing has been achieved through sophisticated synthetic chemistry. Fused thiophene systems currently demonstrate the highest performance in single-crystal devices, while advances in polymer chemistry continue to improve the stability and processability of polythiophene-based transistors.

Key challenges remain, including improving the operational and environmental stability of devices, developing high-performance n-type thiophene semiconductors to enable complementary logic circuits, and scaling up low-cost, solution-based manufacturing processes without compromising performance. The continued synergy between synthetic chemistry, materials science, and device engineering will undoubtedly unlock the full potential of thiophene-based materials for the next generation of flexible and printed electronics.

## References

- Polythiophene-based field-effect transistors with enhanced air stability. *Organic Electronics*.
- Stable operating windows for polythiophene organic electrochemical transistors.
- A new dithieno[3,2-b:2',3'-d]thiophene derivative for high performance single crystal organic field-effect transistors and UV-sensitive phototransistors. *RSC Advances*.
- Oligofluorene–Thiophene Derivatives as High-Performance Semiconductors for Organic Thin Film Transistors.
- Polythiophene-based field-effect transistors with enhanced air stability.
- Impact of hydrophilic side chains on the thin film transistor performance of a benzothieno–benzothiophene derivative.
- OTFT performance of air-stable ester-functionalized polythiophenes.
- Performance Showdown: 3-Acetylthiophene Deriv
- Relationship Between Molecular Structure and Electrical Performance of Oligothiophene Organic Thin Film Transistors.
- Pyrroloindacenodithiophene polymers: the effect of molecular structure on OFET performance. *Polymer Chemistry*.
- Stability of Polythiophene-Based Transistors upon Bending for Gas Sensing Applic
- Performance of 2,5-Bis(5-hydroxymethyl-2-thienyl)furan in OFETs vs.
- High-Performance Organic Field-Effect Transistors: Molecular Design, Device Fabrication, and Physical Properties.

- Assembly, Structure, and Performance of an Ultra-Thin Film Organic Field-Effect Transistor (OFET) Based on Substituted Oligothiophenes.
- Ethylene Glycol Based Side Chain Length Engineering in Polythiophenes and its Impact on Organic Electrochemical Transistor Performance. The University of Liverpool Repository.
- Performance Showdown: Pyreno(1,2-b)thiophene in OFETs versus Leading Organic Semiconductors. Benchchem.
- In-operando characterizations of oligothiophene OFETs: controlling the structure-property relationships
- High-performance, low-voltage organic field-effect transistors using thieno[3,2-b]thiophene and benzothiadiazole co-polymers.
- Oligothiophene Semiconductors: Synthesis, Characterization, and Applications for Organic Devices.
- Examples of p-type fused thiophenes-based organic semiconductors and their OFET performances.
- High performance solution-processable tetrathienoacene (TTAR) based small molecules for organic field effect transistors (OFETs).
- Performance enhancement of air-stable thieno[2,3-b]thiophene organic field-effect transistors via alkyl chain engineering.
- Easily Processable Phenylene–Thiophene-Based Organic Field-Effect Transistors and Solution-Fabricated Nonvolatile Transistor Memory Elements. Journal of the American Chemical Society.
- Experimental Techniques for the Fabrication and Characterization of Organic Thin Films for Field-Effect Transistors. Chemical Reviews.
- A Highly  $\pi$ -Stacked Organic Semiconductor for Thin Film Transistors Based on Fused Thiophenes. Journal of the American Chemical Society.
- Easily Processed Phenylene-Thiophene-Based Organic Field- Effect Transistors and Solution-Fabricated Nonvolatile Transistor Memory Elements.
- Oligo- and polymeric FET devices: Thiophene-based active materials and their interaction with different gate dielectrics.
- High performance organic field-effect transistors based on single-crystal microribbons and microsheets of solution-processed dithieno[3,2-b:2',3'-d] thiophene derivatives.
- Schematic representation of the experimental OFET device configuration and chemical structures of polymer semiconductors and silylating agents.
- Thiophene-based monolayer OFETs prepared by Langmuir techniques.
- Polythiophene. Wikipedia.
- Controlled Synthesis of Poly[(3-alkylthio)thiophene]s and Their Application to Organic Field-Effect Transistors. PubMed.
- Field-Effect Mobility of Organic Polymer Thin-Film Transistors. Semantic Scholar.

### Need Custom Synthesis?

BenchChem offers custom synthesis for rare earth carbides and specific isotopic labeling.

Email: [info@benchchem.com](mailto:info@benchchem.com) or [Request Quote Online](#).

## Sources

- [1. pdf.benchchem.com \[pdf.benchchem.com\]](https://pdf.benchchem.com)
- [2. pubs.acs.org \[pubs.acs.org\]](https://pubs.acs.org)
- [3. researchgate.net \[researchgate.net\]](https://researchgate.net)
- [4. pubs.acs.org \[pubs.acs.org\]](https://pubs.acs.org)
- [5. In-operando characterizations of oligothiophene OFETs: controlling the structure-property relationships at the nanoscale - PMC \[pmc.ncbi.nlm.nih.gov\]](#)
- [6. pdf.benchchem.com \[pdf.benchchem.com\]](https://pdf.benchchem.com)
- [7. Polythiophene - Wikipedia \[en.wikipedia.org\]](https://en.wikipedia.org)
- [8. Controlled Synthesis of Poly\[\(3-alkylthio\)thiophene\]s and Their Application to Organic Field-Effect Transistors - PubMed \[pubmed.ncbi.nlm.nih.gov\]](#)
- [9. Performance enhancement of air-stable thieno\[2,3-b\]thiophene organic field-effect transistors via alkyl chain engineering - Journal of Materials Chemistry C \(RSC Publishing\) \[pubs.rsc.org\]](#)
- [10. OTFT performance of air-stable ester-functionalized polythiophenes - Journal of Materials Chemistry \(RSC Publishing\) \[pubs.rsc.org\]](#)
- [11. Impact of hydrophilic side chains on the thin film transistor performance of a benzothieno–benzothiophene derivative - Materials Advances \(RSC Publishing\) DOI:10.1039/D4MA00594E \[pubs.rsc.org\]](#)
- [12. A new dithieno\[3,2-b:2',3'-d\]thiophene derivative for high performance single crystal organic field-effect transistors and UV-sensitive phototransistors - PMC \[pmc.ncbi.nlm.nih.gov\]](#)
- [13. researchgate.net \[researchgate.net\]](https://researchgate.net)
- [14. researchgate.net \[researchgate.net\]](https://researchgate.net)
- [15. pubs.acs.org \[pubs.acs.org\]](https://pubs.acs.org)
- [16. pubs.acs.org \[pubs.acs.org\]](https://pubs.acs.org)

- [17. pdf.benchchem.com \[pdf.benchchem.com\]](https://pdf.benchchem.com)
- [18. High-performance, low-voltage organic field-effect transistors using thieno\[3,2-b\]thiophene and benzothiadiazole co-polymers - Journal of Materials Chemistry C \(RSC Publishing\) \[pubs.rsc.org\]](#)
- [19. pubs.acs.org \[pubs.acs.org\]](https://pubs.acs.org)
- [20. researchgate.net \[researchgate.net\]](https://researchgate.net)
- [21. researchgate.net \[researchgate.net\]](https://researchgate.net)
- [22. collaborate.princeton.edu \[collaborate.princeton.edu\]](https://collaborate.princeton.edu)
- To cite this document: BenchChem. [Introduction: The Enduring Significance of Thiophene in Organic Electronics]. BenchChem, [2026]. [Online PDF]. Available at: [\[https://www.benchchem.com/product/b1266009/docs#introduction-the-enduring-significance-of-thiophene-in-organic-electronics\]](https://www.benchchem.com/product/b1266009/docs#introduction-the-enduring-significance-of-thiophene-in-organic-electronics)

---

#### Disclaimer & Data Validity:

The information provided in this document is for Research Use Only (RUO) and is strictly not intended for diagnostic or therapeutic procedures. While BenchChem strives to provide accurate protocols, we make no warranties, express or implied, regarding the fitness of this product for every specific experimental setup.

**Technical Support:** The protocols provided are for reference purposes. Unsure if this reagent suits your experiment?

**Need Industrial/Bulk Grade?** [Request Custom Synthesis Quote](#)

## BenchChem

Our mission is to be the trusted global source of essential and advanced chemicals, empowering scientists and researchers to drive progress in science and industry.

#### Contact

Address: 3281 E Guasti Rd  
Ontario, CA 91761, United States  
Phone: (601) 213-4426  
Email: [info@benchchem.com](mailto:info@benchchem.com)

Contact our Ph.D. Support Team for a compatibility check