

Application Notes: The Role of TPD in Enhancing Charge Injection in Organic Electronics

Author: BenchChem Technical Support Team. **Date:** May 2026

Compound of Interest

Compound Name:	<i>N,N'</i> -Bis(3-methylphenyl)- <i>N,N'</i> -bis(phenyl)benzidine
CAS No.:	65181-78-4
Cat. No.:	B1266666

[Get Quote](#)

AN-TPD-001

Introduction

In the field of organic electronics, the performance of devices such as Organic Light-Emitting Diodes (OLEDs) and organic photovoltaics (OPVs) is critically dependent on the efficiency of charge injection and transport between layers. One of the most significant challenges is overcoming the energy barrier between the anode (typically Indium Tin Oxide, ITO) and the organic emissive or active layer. *N,N'*-bis(3-methylphenyl)-*N,N'*-diphenylbenzidine, commonly known as TPD, is a benchmark small molecule organic semiconductor widely employed as a Hole Transport Material (HTM) to address this issue. Its primary function is to facilitate the efficient injection and transport of holes from the anode to the emissive layer, thereby lowering the device's operating voltage and improving its overall efficiency and brightness.[1][2]

Mechanism of Action

The effectiveness of TPD as a hole transport layer stems from two key properties: its suitable energy level alignment and its high hole mobility.

- **Energy Level Alignment:** The work function of a standard ITO anode is approximately 4.7 eV. [2] Many organic emissive materials have a Highest Occupied Molecular Orbital (HOMO) energy level that is significantly deeper (e.g., >5.5 eV). This large energy difference creates a substantial barrier for holes to be injected from the anode into the emissive layer. TPD possesses a HOMO level of around 5.5 eV, which is positioned intermediately between the ITO work function and the HOMO level of many common emissive materials.[1] By inserting a thin layer of TPD, the large single energy barrier is replaced by two smaller, more manageable steps, significantly reducing the injection barrier and facilitating a more efficient flow of holes.
- **Charge Carrier Mobility:** Once injected, holes must travel efficiently through the organic layer to reach the emissive layer for recombination with electrons. TPD is characterized by high hole mobility (on the order of 10^{-3} cm²/V·s), which ensures rapid and efficient transport of positive charge carriers with minimal resistance.[3] This property is crucial for achieving high current densities at low operating voltages.[1] The combination of reduced injection barrier and enhanced hole transport leads to a more balanced charge carrier population in the emissive layer, which in turn increases the probability of radiative recombination and enhances device efficiency.

Quantitative Data on TPD-Enhanced Device Performance

The inclusion of a TPD hole transport layer in a standard OLED device leads to significant improvements in key performance metrics. The following table summarizes the typical performance enhancement observed in a simple bilayer OLED structure comparing a device with and without a TPD layer.

Device Structure	Metric	Value	Reference
Without TPD (ITO / Alq ₃ / Al)	Turn-on Voltage	> 8 V	[2]
Max. Luminance	~ 500 cd/m ²	[4]	
Current Efficiency	~ 1.0 cd/A	[5]	
With TPD (ITO / TPD / Alq ₃ / Al)	Turn-on Voltage	< 5 V	[4]
Max. Luminance	> 10,000 cd/m ²	[4]	
Current Efficiency	> 3.0 cd/A	[5]	

Note: The values presented are representative and can vary based on specific material thicknesses, deposition conditions, and device architecture.

Visualizations

Energy Level Diagram for Hole Injection

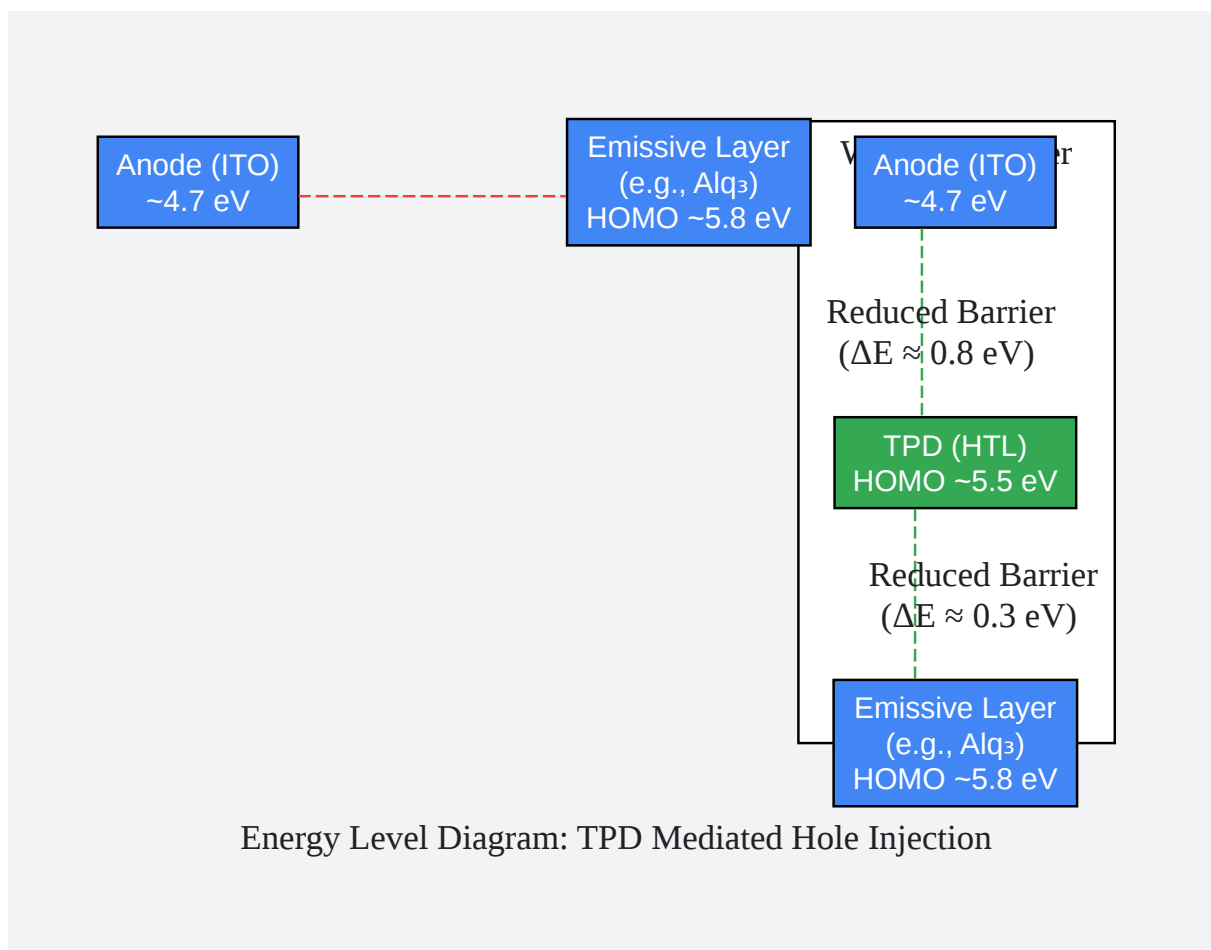

[Click to download full resolution via product page](#)

Caption: Energy levels showing TPD reducing the hole injection barrier.

Logical Flow of TPD's Role

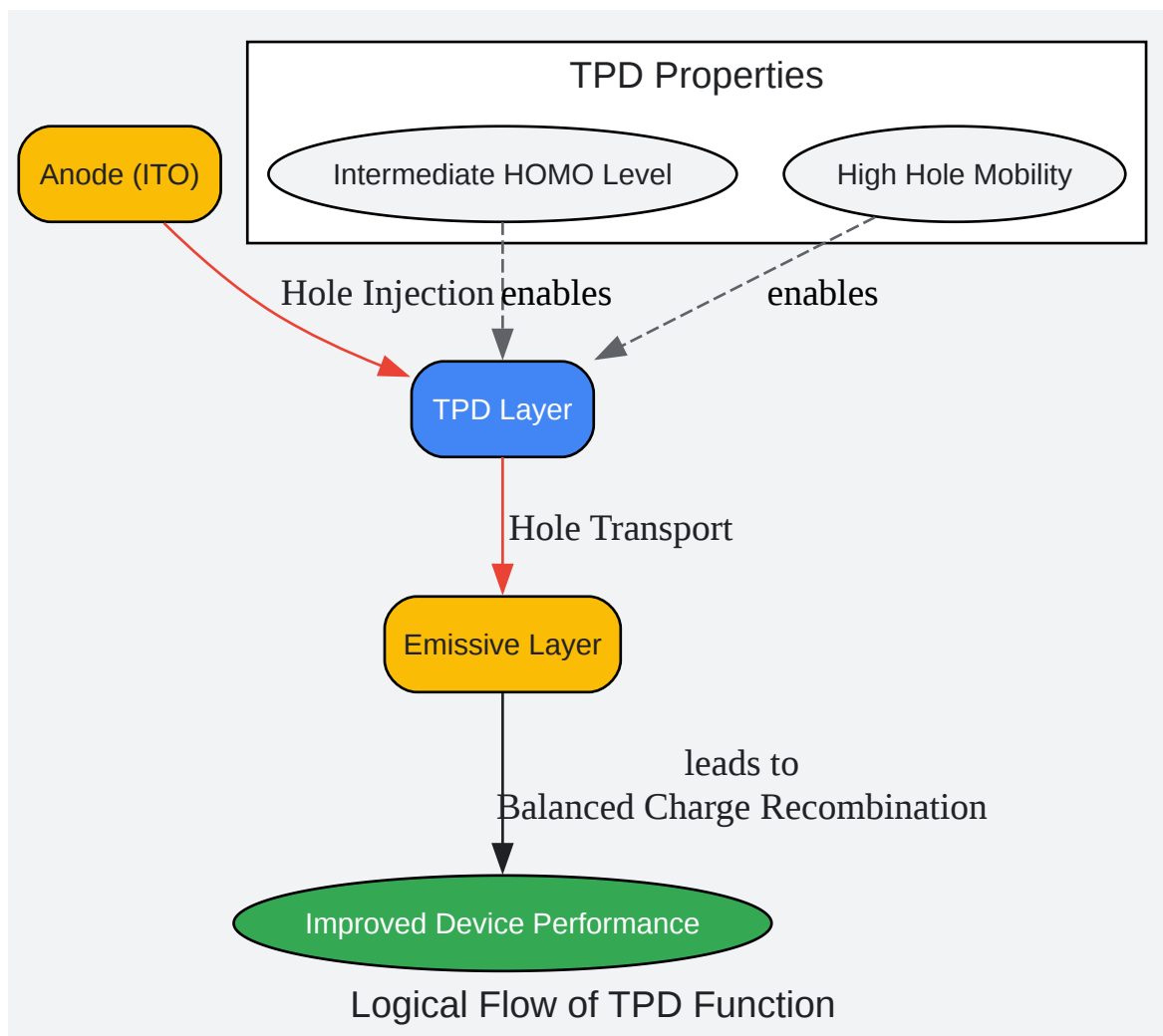

[Click to download full resolution via product page](#)

Caption: TPD's properties facilitate efficient hole injection and transport.

Experimental Protocols

This section provides a standard protocol for fabricating a simple OLED device incorporating a TPD hole transport layer using vacuum thermal evaporation.

1. Substrate Preparation and Cleaning

Objective: To prepare a clean and pristine Indium Tin Oxide (ITO) coated glass substrate to ensure good film adhesion and device performance.

- Initial Cleaning: Place ITO-coated glass substrates in a substrate holder.

- Sonication: Sequentially sonicate the substrates in the following solvents for 15 minutes each:
 - Detergent solution (e.g., Decon 90 or Alconox)
 - Deionized (DI) water (rinse thoroughly)
 - Acetone
 - Isopropanol (IPA)
- Drying: After the final sonication step, dry the substrates using a stream of high-purity nitrogen gas.
- Surface Treatment: Immediately before loading into the vacuum chamber, treat the ITO surface with UV-Ozone or Oxygen Plasma for 5-10 minutes. This step removes organic residues and increases the ITO work function, which further improves hole injection.[4]

2. Device Fabrication via Vacuum Thermal Evaporation (VTE)

Objective: To deposit the multilayer organic device stack in a high-vacuum environment to prevent contamination and ensure high-quality thin films.

- System Preparation: Load the cleaned substrates into a high-vacuum thermal evaporation chamber. The base pressure of the chamber should be below 5×10^{-6} Torr before starting deposition.[6]
- Material Sources: TPD, Alq₃ (tris(8-hydroxyquinolino)aluminum), LiF, and Al are placed in separate resistive heating boats (e.g., molybdenum, tantalum, or tungsten) or crucibles.

Deposition Sequence:

- Hole Transport Layer (TPD):
 - Heat the TPD source slowly until it begins to evaporate.
 - Deposit a 40 nm thick layer of TPD onto the ITO substrate.

- Maintain a stable deposition rate of 1-2 Å/s, monitored using a quartz crystal microbalance (QCM).
- Emissive Layer (Alq_3):
 - Without breaking vacuum, deposit a 60 nm thick layer of Alq_3 .
 - Maintain a stable deposition rate of 1-2 Å/s.
- Electron Injection Layer (LiF):
 - Deposit a thin 0.8 - 1.0 nm layer of Lithium Fluoride (LiF).
 - Use a slower deposition rate of 0.1-0.2 Å/s for better thickness control.
- Cathode (Al):
 - Deposit a 100-150 nm thick layer of Aluminum (Al) to serve as the cathode.^[2]
 - A higher deposition rate of 5-10 Å/s can be used.

3. Encapsulation and Characterization

- Encapsulation: After deposition, the device should be encapsulated immediately in an inert atmosphere (e.g., a nitrogen-filled glovebox) to prevent degradation from moisture and oxygen. A glass lid is typically sealed over the device using a UV-curable epoxy resin.
- Characterization:
 - The current density-voltage-luminance (J-V-L) characteristics are measured using a source meter unit connected to a calibrated photodiode or spectrometer.
 - From this data, key performance parameters like turn-on voltage, external quantum efficiency (EQE), and power efficiency can be calculated.

Experimental Workflow Diagram

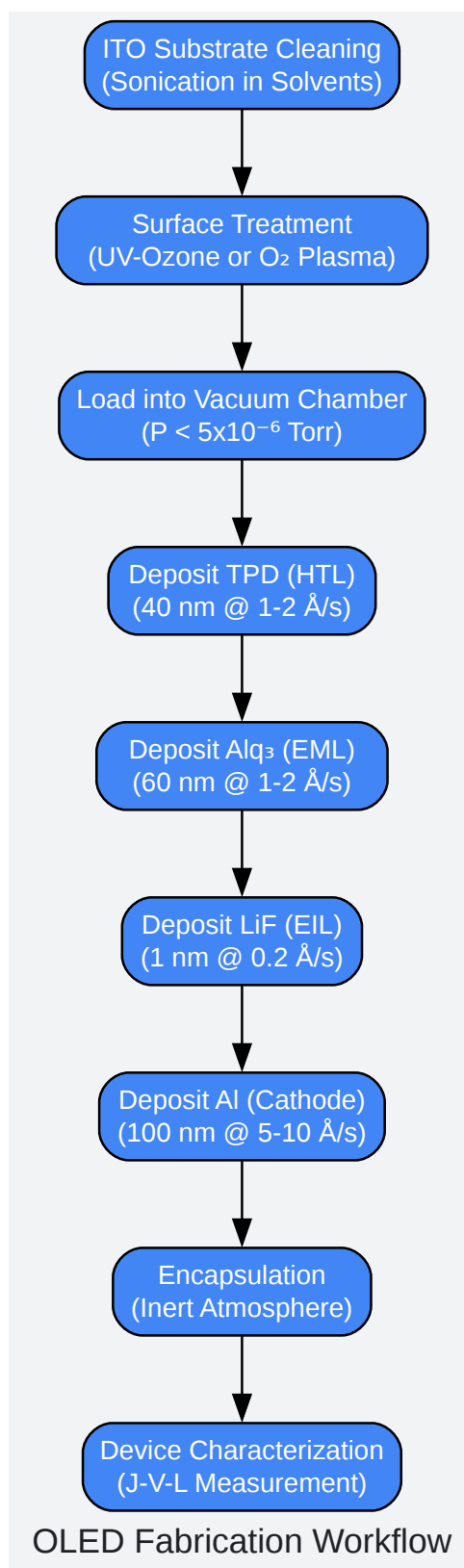

[Click to download full resolution via product page](#)

Caption: Step-by-step workflow for fabricating a TPD-based OLED.

Need Custom Synthesis?

BenchChem offers custom synthesis for rare earth carbides and specific isotopic labeling.

Email: info@benchchem.com or [Request Quote Online](#).

References

- [1. nbinno.com](http://nbinno.com) [nbinno.com]
- [2. researchgate.net](http://researchgate.net) [researchgate.net]
- [3. OPG](http://opg.optica.org) [opg.optica.org]
- [4. pubs.aip.org](http://pubs.aip.org) [pubs.aip.org]
- [5. Lifetime Comparisons of Organic Light-Emitting Diodes Fabricated by Solution and Evaporation Processes - PMC](#) [pmc.ncbi.nlm.nih.gov]
- [6. researchgate.net](http://researchgate.net) [researchgate.net]
- To cite this document: BenchChem. [Application Notes: The Role of TPD in Enhancing Charge Injection in Organic Electronics]. BenchChem, [2026]. [Online PDF]. Available at: [<https://www.benchchem.com/product/b1266666/docs#application-notes-the-role-of-tpd-in-enhancing-charge-injection-in-organic-electronics>]

Disclaimer & Data Validity:

The information provided in this document is for Research Use Only (RUO) and is strictly not intended for diagnostic or therapeutic procedures. While BenchChem strives to provide accurate protocols, we make no warranties, express or implied, regarding the fitness of this product for every specific experimental setup.

Technical Support: The protocols provided are for reference purposes. Unsure if this reagent suits your experiment?

Need Industrial/Bulk Grade? [Request Custom Synthesis Quote](#)

BenchChem

Our mission is to be the trusted global source of essential and advanced chemicals, empowering scientists and researchers to drive progress in science and industry.

Contact

Address: 3281 E Guasti Rd

Ontario, CA 91761, United States

Phone: (601) 213-4426

Email: info@benchchem.com

[Contact our Ph.D. Support Team for a compatibility check](#)