

A Guide to Fourier-Transform Infrared Spectroscopy of Long-Chain Alcohols

Author: BenchChem Technical Support Team. **Date:** May 2026

Compound of Interest

Compound Name: 9-Heptadecanol

CAS No.: 624-08-8

Cat. No.: B1266218

[Get Quote](#)

An In-depth Technical Guide for Researchers, Scientists, and Drug Development Professionals

Introduction

Fourier-transform infrared (FTIR) spectroscopy is a powerful analytical technique for the qualitative and quantitative analysis of long-chain alcohols. These compounds, characterized by a hydroxyl group attached to a long alkyl chain, are fundamental components in various fields, including pharmaceuticals, cosmetics, and industrial lubricants. FTIR spectroscopy provides valuable information about the molecular structure, functional groups, and purity of long-chain alcohols, and can be used for quantitative determination in various matrices. This guide provides a comprehensive overview of the principles, experimental protocols, and data interpretation for the FTIR analysis of long-chain alcohols.

Core Principles of FTIR Spectroscopy of Alcohols

FTIR spectroscopy measures the absorption of infrared radiation by a sample as a function of wavenumber. When a molecule absorbs infrared radiation, it undergoes a transition to a higher vibrational state. The specific wavenumbers at which a molecule absorbs radiation are characteristic of its molecular structure and the types of chemical bonds present.

For long-chain alcohols, the most prominent and characteristic absorption bands are associated with the hydroxyl (-OH) and alkyl (C-H) functional groups.

Key Vibrational Modes:

- **O-H Stretching:** The stretching vibration of the hydroxyl group is highly sensitive to hydrogen bonding. In concentrated samples or in the presence of hydrogen bond acceptors, this appears as a broad and intense absorption band in the region of 3200-3600 cm^{-1} . In dilute solutions with non-polar solvents, a sharper "free" O-H stretching band may be observed around 3600-3700 cm^{-1} .
- **C-H Stretching:** The stretching vibrations of the alkyl chain's C-H bonds typically appear as strong, sharp bands in the region of 2850-3000 cm^{-1} .
- **C-O Stretching:** The stretching vibration of the carbon-oxygen single bond results in a strong absorption band in the fingerprint region, typically between 1000 and 1260 cm^{-1} . The exact position of this band can provide information about whether the alcohol is primary, secondary, or tertiary.^{[1][2][3][4][5]}
- **O-H Bending:** The in-plane bending of the O-H group appears in the region of 1350-1450 cm^{-1} .
- **CH₂ and CH₃ Bending:** The bending (scissoring, wagging, and twisting) vibrations of the methylene (CH₂) and methyl (CH₃) groups of the alkyl chain give rise to a series of bands in the fingerprint region, typically between 1350 and 1470 cm^{-1} .

Quantitative Analysis

FTIR spectroscopy can be a powerful tool for the quantitative analysis of long-chain alcohols. The Beer-Lambert law states that the absorbance of a specific vibrational band is directly proportional to the concentration of the analyte. By preparing a series of standards with known concentrations and measuring their absorbance at a characteristic wavenumber, a calibration curve can be constructed. The concentration of an unknown sample can then be determined by measuring its absorbance and interpolating from the calibration curve.

For complex mixtures, multivariate calibration techniques such as Partial Least Squares (PLS) regression may be employed. These methods use a larger portion of the spectral data to build

a more robust calibration model that can account for overlapping peaks and matrix effects.[\[6\]](#)[\[7\]](#)
[\[8\]](#)[\[9\]](#)[\[10\]](#)

Quantitative Data for Long-Chain Alcohols

Analyte(s)	Matrix	Wavenumber(s) Used (cm ⁻¹)	Calibration Model	Correlation Coefficient (R ²)	Notes
Dodecanol, Tetradecanol, Octadecanol	Machinery Oils	Not specified	Not specified	Not specified	Successful quantitative determination reported.
Fusel Alcohols (higher-chain alcohols)	Grape-Derived Spirits	Full spectrum	PLS	0.941 - 0.974	RPD values from 4.1 to 6.2 indicate good model performance.

RPD: Ratio of Performance to Deviation

Experimental Protocols

The choice of experimental protocol for FTIR analysis of long-chain alcohols depends on the physical state of the sample (solid, liquid, or solution) and the desired information (qualitative or quantitative).

Sample Preparation

For Solid, Waxy Long-Chain Alcohols:

- **Attenuated Total Reflectance (ATR):** This is often the simplest method for solid samples. A small amount of the solid is placed directly onto the ATR crystal (e.g., diamond or zinc selenide) and pressure is applied to ensure good contact. The applied pressure can affect the spectrum, so it should be consistent across samples for quantitative analysis. For waxy samples, gentle warming of the ATR crystal may improve contact.[\[11\]](#)[\[12\]](#)[\[13\]](#)[\[14\]](#)

- **Potassium Bromide (KBr) Pellets:** A small amount of the finely ground solid alcohol (typically 1-2 mg) is intimately mixed with dry KBr powder (around 200 mg). The mixture is then pressed under high pressure in a die to form a transparent pellet. This method requires care to avoid moisture contamination, as water has strong IR absorption bands. For waxy samples, grinding at cryogenic temperatures (after freezing with liquid nitrogen) can improve powder fineness.
- **Mulls:** A mull is prepared by grinding the solid sample with a mulling agent (e.g., Nujol or Fluorolube) to form a paste. This paste is then spread between two IR-transparent windows (e.g., NaCl or KBr). The mulling agent has its own characteristic IR absorption bands, which must be taken into account.

For Liquid Long-Chain Alcohols or Solutions:

- **Liquid Cells:** The liquid sample is placed in a cell with IR-transparent windows (e.g., NaCl, KBr, CaF₂). The path length of the cell is fixed and known, which is crucial for quantitative analysis.
- **ATR:** A drop of the liquid is placed directly on the ATR crystal. This is a quick and easy method for qualitative analysis and can also be used for quantitative analysis if the sample volume and contact are carefully controlled.

Instrument Parameters

Typical instrument parameters for the FTIR analysis of long-chain alcohols are:

- **Spectral Range:** 4000 - 400 cm⁻¹
- **Resolution:** 4 cm⁻¹
- **Number of Scans:** 16 to 64 scans are typically co-added to improve the signal-to-noise ratio.
- **Apodization:** A mathematical function applied to the interferogram to reduce spectral artifacts. Common functions include Happ-Genzel and Blackman-Harris.

Data Interpretation and Spectral Features

The FTIR spectrum of a long-chain alcohol is dominated by the features of the hydroxyl and alkyl groups. The following table summarizes the characteristic absorption bands and their assignments for some common long-chain alcohols.

Vibrational Mode	1-Dodecanol (cm ⁻¹)	1-Tetradecanol (cm ⁻¹)	1-Octadecanol (cm ⁻¹)	General Range for Long-Chain Alcohols (cm ⁻¹)
O-H Stretch (H-bonded)	~3320 (broad, strong)[15]	Not specified	Not specified	3200 - 3600 (broad, strong)[1][3]
C-H Asymmetric Stretch (CH ₃)	Not specified	~2955	~2955	~2950 - 2970
C-H Asymmetric Stretch (CH ₂)	~2921 (strong) [15]	~2916	~2916	~2915 - 2935
C-H Symmetric Stretch (CH ₂)	~2852 (strong) [15]	~2849	~2849	~2845 - 2865
C-H Bend (CH ₂)	~1462[15]	~1472	~1468	~1450 - 1475
C-O Stretch	~1063	~1057	~1061	1000 - 1260 (strong)[1][2][3][4][5]
O-H Out-of-Plane Bend	Not specified	~950	~950	~650 - 800 (broad)

Visualization of Experimental Workflows

General FTIR Analysis Workflow

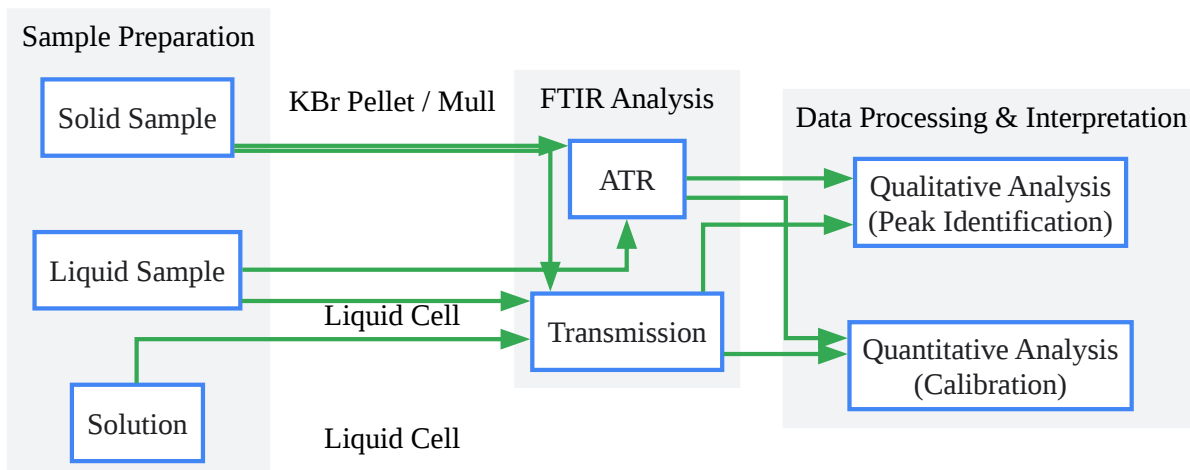

[Click to download full resolution via product page](#)

Caption: General workflow for FTIR analysis of long-chain alcohols.

Quantitative Analysis Workflow using Calibration Curve

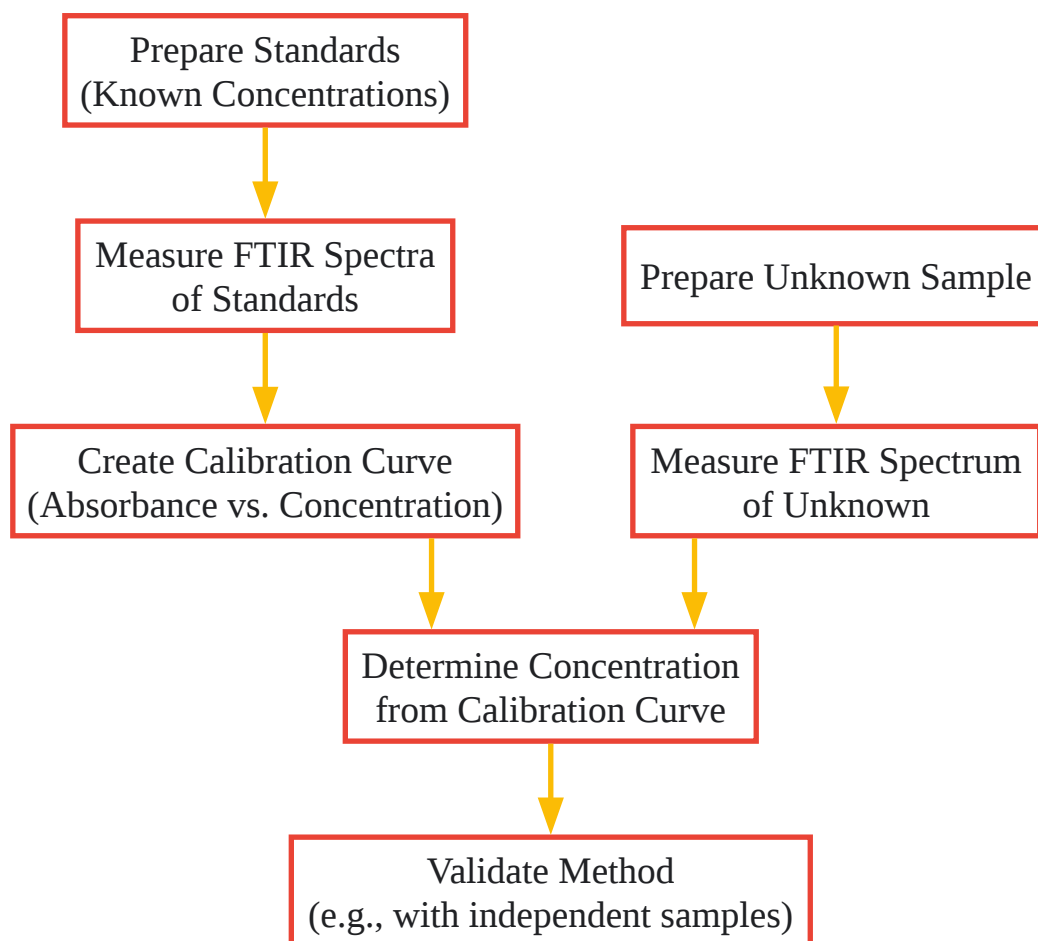

[Click to download full resolution via product page](#)

Caption: Workflow for quantitative analysis using a calibration curve.

Conclusion

FTIR spectroscopy is a versatile and valuable technique for the analysis of long-chain alcohols. Its ability to provide detailed information about molecular structure and to be used for quantitative analysis makes it an indispensable tool for researchers, scientists, and drug development professionals. By following the appropriate experimental protocols and understanding the principles of data interpretation, FTIR can be effectively applied to a wide range of applications involving long-chain alcohols.

Need Custom Synthesis?

BenchChem offers custom synthesis for rare earth carbides and specific isotopic labeling.

Email: info@benchchem.com or [Request Quote Online](#).

References

- [1. orgchemboulder.com](https://orgchemboulder.com) [orgchemboulder.com]
- [2. spectroscopyonline.com](https://spectroscopyonline.com) [spectroscopyonline.com]
- [3. allsubjectjournal.com](https://allsubjectjournal.com) [allsubjectjournal.com]
- [4. chem.libretexts.org](https://chem.libretexts.org) [chem.libretexts.org]
- [5. chem.libretexts.org](https://chem.libretexts.org) [chem.libretexts.org]
- [6. ifrj.upm.edu.my](https://ifrj.upm.edu.my) [ifrj.upm.edu.my]
- [7. agilent.com](https://agilent.com) [agilent.com]
- [8. notulaebotanicae.ro](https://notulaebotanicae.ro) [notulaebotanicae.ro]
- [9. notulaebotanicae.ro](https://notulaebotanicae.ro) [notulaebotanicae.ro]
- [10. Simultaneous Determination of Ethanol and Methanol in Wines Using FTIR and PLS Regression - PMC](https://pubmed.ncbi.nlm.nih.gov/31111111/) [pmc.ncbi.nlm.nih.gov]
- [11. researchgate.net](https://www.researchgate.net/publication/31111111) [researchgate.net]
- [12. researchgate.net](https://www.researchgate.net/publication/31111111) [researchgate.net]
- [13. spectroscopyonline.com](https://spectroscopyonline.com) [spectroscopyonline.com]
- [14. d-nb.info](https://d-nb.info) [d-nb.info]
- [15. researchgate.net](https://www.researchgate.net/publication/31111111) [researchgate.net]
- To cite this document: BenchChem. [A Guide to Fourier-Transform Infrared Spectroscopy of Long-Chain Alcohols]. BenchChem, [2026]. [Online PDF]. Available at: [https://www.benchchem.com/product/b1266218/docs#a-guide-to-fourier-transform-infrared-spectroscopy-of-long-chain-alcohols]

Disclaimer & Data Validity:

The information provided in this document is for Research Use Only (RUO) and is strictly not intended for diagnostic or therapeutic procedures. While BenchChem strives to provide accurate protocols, we make no warranties, express or implied, regarding the fitness of this product for every specific experimental setup.

Technical Support: The protocols provided are for reference purposes. Unsure if this reagent suits your experiment?

Need Industrial/Bulk Grade? [Request Custom Synthesis Quote](#)

BenchChem

Our mission is to be the trusted global source of essential and advanced chemicals, empowering scientists and researchers to drive progress in science and industry.

Contact

Address: 3281 E Guasti Rd
Ontario, CA 91761, United States
Phone: (601) 213-4426
Email: info@benchchem.com

[Contact our Ph.D. Support Team for a compatibility check](#)