

# Vanadium Pentachloride as a Catalyst in Organic Synthesis: Application Notes and Protocols

**Author:** BenchChem Technical Support Team. **Date:** May 2026

## Compound of Interest

Compound Name: Vanadium pentachloride

CAS No.: 14986-47-1

Cat. No.: B12657192

[Get Quote](#)

For Researchers, Scientists, and Drug Development Professionals

## Introduction

**Vanadium pentachloride** ( $\text{VCl}_5$ ), while highly reactive and unstable, serves as a potent precursor for catalytically active vanadium species in various organic transformations. Due to its tendency to readily decompose to the more stable vanadium(IV) chloride ( $\text{VCl}_4$ ),  $\text{VCl}_5$  is often generated in situ or  $\text{VCl}_4$  is used directly as the catalyst precursor. Vanadium-based catalysts demonstrate significant utility in polymerization, oxidative coupling, and halogenation reactions, offering unique reactivity and selectivity. These application notes provide detailed protocols and quantitative data for key synthetic applications, focusing on methodologies where  $\text{VCl}_5$  acts as a precursor to the active catalytic species.

## Olefin Polymerization: Ziegler-Natta Catalysis

Vanadium chlorides, particularly  $\text{VCl}_4$ , are effective catalysts for the polymerization of olefins, such as ethylene, often as a component of Ziegler-Natta catalyst systems. These systems typically involve a vanadium compound and an organoaluminum co-catalyst. The use of a

magnesium chloride support can significantly enhance the activity and stability of the vanadium catalyst.

## Quantitative Data for Ethylene Polymerization

Catalyst System	Co-catalyst	Polymerization Time (min)	Activity (kg PE / (g V·h))	Molecular Weight (M <sub>n</sub> )
VCl <sub>4</sub> /MgCl <sub>2</sub> (THF) <sub>2</sub>	Et <sub>2</sub> AlCl	30	150	High
VCl <sub>4</sub> /MgCl <sub>2</sub> (THF) <sub>2</sub>	Et <sub>2</sub> AlCl	60	140	High
VCl <sub>4</sub> /MgCl <sub>2</sub> (THF) <sub>2</sub>	Et <sub>2</sub> AlCl	120	125	High

## Experimental Protocol: Ethylene Polymerization

Materials:

- Vanadium tetrachloride (VCl<sub>4</sub>)
- Magnesium chloride bis(tetrahydrofuran) complex (MgCl<sub>2</sub>(THF)<sub>2</sub>)
- Diethylaluminum chloride (Et<sub>2</sub>AlCl)
- Hexane (anhydrous, oxygen-free)
- Ethylene (polymerization grade)
- Methanol
- Hydrochloric acid (5% in methanol)
- Argon (high purity)

Equipment:

- 1 L stainless steel reactor equipped with a mechanical stirrer

- Schlenk line and standard glassware for air-sensitive manipulations
- Ball mill
- Filtration apparatus

#### Catalyst Preparation ( $\text{VCl}_4/\text{MgCl}_2(\text{THF})_2$ ):[1]

- Under an inert argon atmosphere, place  $\text{MgCl}_2(\text{THF})_2$  into a ball mill.
- Add  $\text{VCl}_4$  to the ball mill.
- Mill the mixture in hexane at room temperature for 24 hours to ensure homogeneous distribution of the vanadium species on the support.[1]
- The resulting solid is the supported vanadium catalyst precursor.

#### Polymerization Procedure:[2]

- Ensure the 1 L reactor is thoroughly dried and purged with argon.
- Introduce 0.7 L of anhydrous, oxygen-free hexane into the reactor.[2]
- Add the desired amount of the  $\text{VCl}_4/\text{MgCl}_2(\text{THF})_2$  catalyst precursor to the reactor.
- Introduce the  $\text{Et}_2\text{AlCl}$  co-catalyst into the reactor.
- Pressurize the reactor with ethylene to the desired pressure (e.g., 0.5 MPa) while stirring vigorously.[2]
- Maintain a constant temperature (e.g., 25 °C) and ethylene pressure throughout the polymerization.[2]
- After the desired reaction time, terminate the polymerization by adding a 5% solution of hydrochloric acid in methanol.[2]
- Filter the resulting polyethylene, wash thoroughly with methanol, and dry under vacuum.[2]

#### Characterization:

- The molecular weight of the polyethylene can be determined by viscometry in decalin at 135 °C.[2]
- The melting point and degree of crystallinity can be measured using differential scanning calorimetry (DSC).[2]

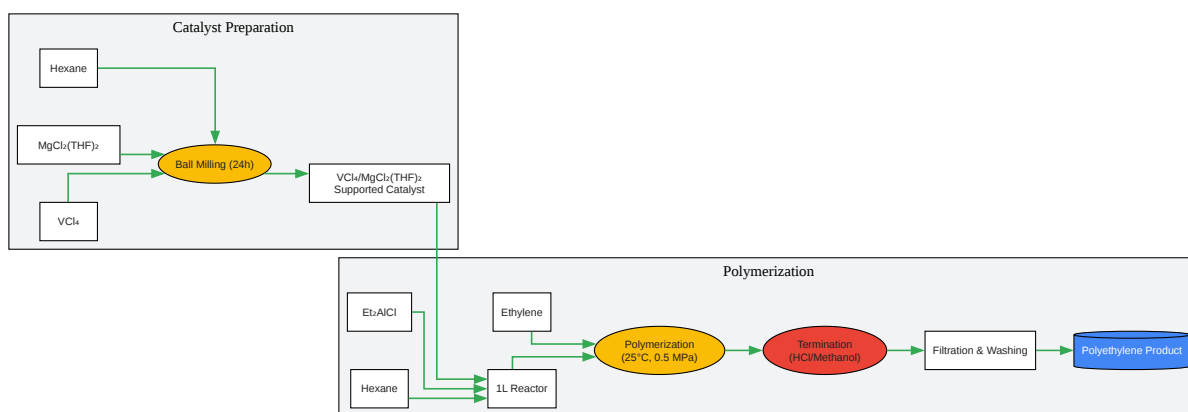

[Click to download full resolution via product page](#)

### Ethylene Polymerization Workflow

## Oxidative Coupling of Phenols

Vanadium tetrachloride is a known reagent for the oxidative coupling of phenols, leading to the formation of biphenols. This reaction proceeds via a one-electron oxidation mechanism.[3] The product distribution can vary depending on the substitution pattern of the phenol.

## Quantitative Data for Oxidative Coupling of Phenol

Reagent	Product	Isomer Distribution	Yield (%)
VCl <sub>4</sub>	4,4'-Biphenol	para-para	44
VCl <sub>4</sub>	2,4'-Biphenol	ortho-para	18
VCl <sub>4</sub>	2,2'-Biphenol	ortho-ortho	Not Observed

## Experimental Protocol: Oxidative Coupling of Phenol

Materials:

- Vanadium tetrachloride (VCl<sub>4</sub>)
- Phenol
- Anhydrous diethyl ether
- Hydrochloric acid (aqueous)
- Sodium bicarbonate (saturated aqueous solution)
- Brine
- Anhydrous magnesium sulfate
- Silica gel for column chromatography

Equipment:

- Round-bottom flask with a magnetic stirrer
- Dropping funnel
- Inert atmosphere setup (e.g., Schlenk line or glovebox)
- Standard laboratory glassware for extraction and chromatography

## Procedure:

- Under an inert atmosphere, dissolve phenol in anhydrous diethyl ether in a round-bottom flask and cool the solution to  $-78\text{ }^{\circ}\text{C}$ .
- Slowly add a solution of vanadium tetrachloride in anhydrous diethyl ether to the cooled phenol solution via a dropping funnel. Hydrogen chloride evolution may be observed.
- After the addition is complete, allow the reaction mixture to warm to room temperature and stir for several hours.
- Quench the reaction by carefully adding water.
- Transfer the mixture to a separatory funnel and extract with diethyl ether.
- Wash the combined organic layers sequentially with water, saturated sodium bicarbonate solution, and brine.
- Dry the organic layer over anhydrous magnesium sulfate, filter, and concentrate under reduced pressure.
- Purify the crude product by silica gel column chromatography to separate the isomeric biphenols.

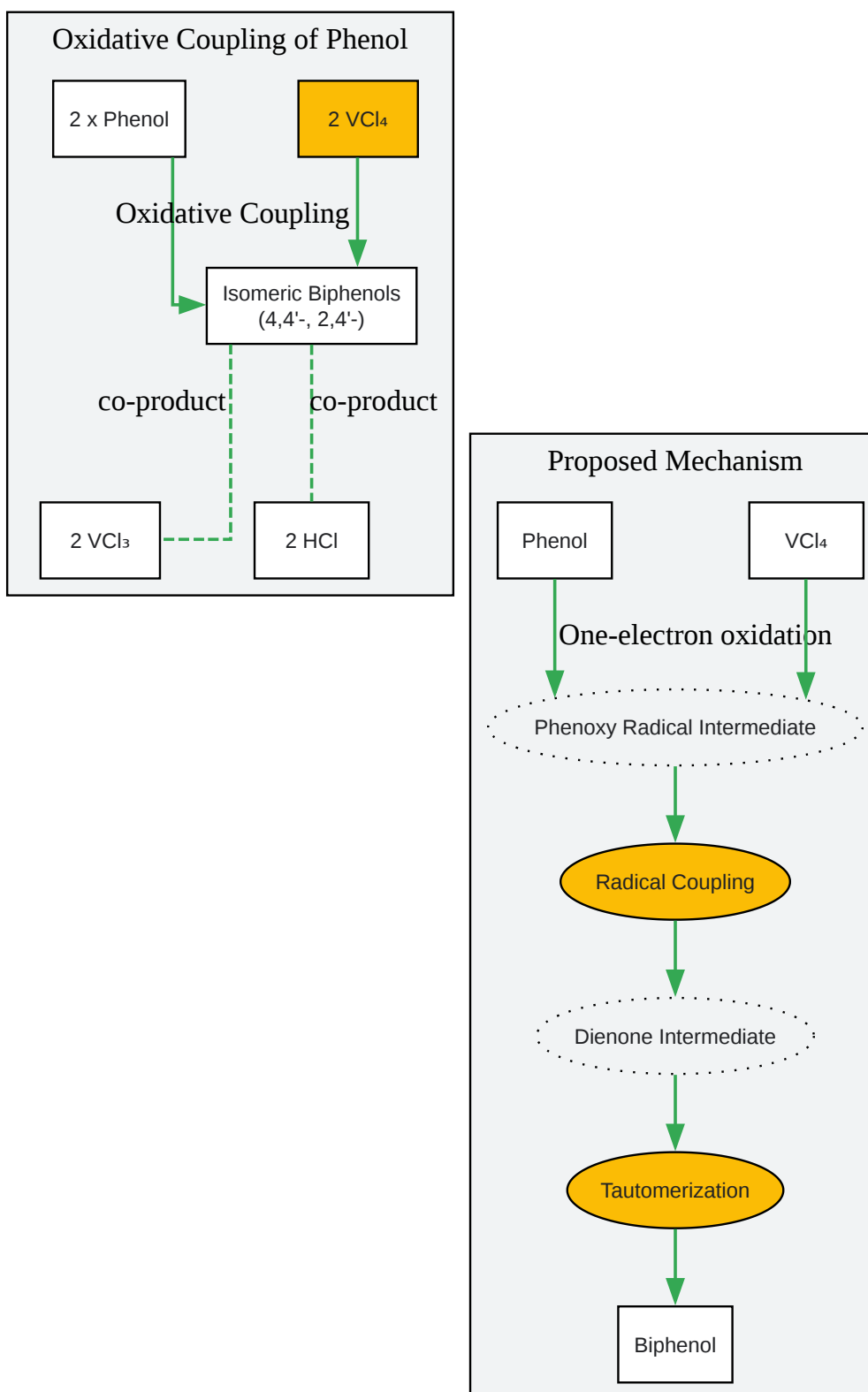

[Click to download full resolution via product page](#)

### Oxidative Coupling of Phenols

## Halogenation Reactions

Vanadium compounds can catalyze oxidative halogenation reactions, providing an environmentally benign alternative to the use of elemental halogens. These systems typically use a halide salt as the halogen source and an oxidant, such as molecular oxygen or hydrogen peroxide. While specific protocols using  $VCl_5$  or  $VCl_4$  are not widely detailed, the general principle involves the in-situ generation of an active halogenating species by the vanadium catalyst. Vanadium-dependent haloperoxidases, for instance, are known to catalyze the chlorination of various organic substrates.

### General Principles of Vanadium-Catalyzed Chlorination

A vanadium catalyst, in a higher oxidation state, can oxidize chloride ions (from a salt like NaCl or KCl) in the presence of an oxidant (e.g.,  $H_2O_2$ ). This generates a reactive electrophilic chlorine species, which then chlorinates the organic substrate. The reduced vanadium catalyst is subsequently re-oxidized by the terminal oxidant to complete the catalytic cycle.

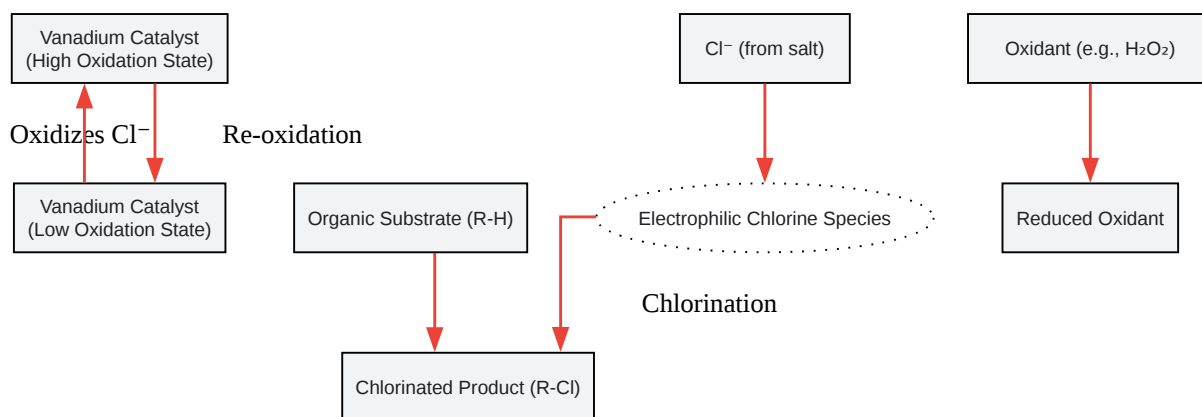

[Click to download full resolution via product page](#)

#### Vanadium-Catalyzed Halogenation Cycle

## Conclusion

While **vanadium pentachloride** itself is challenging to handle due to its instability, it serves as a valuable precursor for the generation of catalytically active vanadium species, primarily

vanadium tetrachloride. These catalysts exhibit significant potential in organic synthesis, particularly in olefin polymerization and the oxidative coupling of phenols. The provided protocols offer a foundation for researchers to explore the utility of vanadium-catalyzed transformations in their own work. Further research into stabilizing vanadium(V) species and developing robust protocols for other transformations, such as halogenation, will continue to expand the synthetic utility of this versatile transition metal.

#### Need Custom Synthesis?

BenchChem offers custom synthesis for rare earth carbides and specific isotopic labeling.

Email: [info@benchchem.com](mailto:info@benchchem.com) or [Request Quote Online](#).

## References

- [1. researchgate.net \[researchgate.net\]](https://www.researchgate.net)
- [2. archiwum.ichp.vot.pl \[archiwum.ichp.vot.pl\]](https://www.archiwum.ichp.vot.pl)
- [3. Oxidative coupling of phenols - Wikipedia \[en.wikipedia.org\]](https://en.wikipedia.org)
- To cite this document: BenchChem. [Vanadium Pentachloride as a Catalyst in Organic Synthesis: Application Notes and Protocols]. BenchChem, [2026]. [Online PDF]. Available at: [\[https://www.benchchem.com/product/b12657192/docs#vanadium-pentachloride-as-a-catalyst-in-organic-synthesis-application-notes-and-protocols\]](https://www.benchchem.com/product/b12657192/docs#vanadium-pentachloride-as-a-catalyst-in-organic-synthesis-application-notes-and-protocols)

#### Disclaimer & Data Validity:

The information provided in this document is for Research Use Only (RUO) and is strictly not intended for diagnostic or therapeutic procedures. While BenchChem strives to provide accurate protocols, we make no warranties, express or implied, regarding the fitness of this product for every specific experimental setup.

**Technical Support:** The protocols provided are for reference purposes. Unsure if this reagent suits your experiment?

**Need Industrial/Bulk Grade?** [Request Custom Synthesis Quote](#)

# BenchChem

Our mission is to be the trusted global source of essential and advanced chemicals, empowering scientists and researchers to drive progress in science and industry.

## Contact

Address: 3281 E Guasti Rd

Ontario, CA 91761, United States

Phone: (601) 213-4426

Email: [info@benchchem.com](mailto:info@benchchem.com)

[Contact our Ph.D. Support Team for a compatibility check](#)