

# Comparative Guide: Uranyl Oxalate Actinometry in High-Precision Photochemistry

**Author:** BenchChem Technical Support Team. **Date:** May 2026

## Compound of Interest

Compound Name: (Oxalato(2-)-O,O')dioxouranium

CAS No.: 2031-89-2

Cat. No.: B12653824

[Get Quote](#)

## Executive Summary

Status: Historical Reference Standard (UV Region) Verdict: While Potassium Ferrioxalate has largely superseded Uranyl Oxalate for general actinometry due to higher sensitivity and safety, Uranyl Oxalate (

) remains the superior choice for high-intensity UV applications (208–300 nm) where ferrioxalate degrades too rapidly or saturates.

This guide provides an objective inter-laboratory comparison of quantum yield (

) measurements, analyzing the discrepancies between historical baselines and modern IUPAC standards. It serves as a technical manual for researchers requiring absolute photon flux quantification in stability testing and photolysis studies.

## Technical Foundation: The Mechanism

The Uranyl Oxalate actinometer operates on the principle of photosensitized decomposition.[1] Unlike direct photolysis, the uranyl ion (

) acts as a photocatalyst.

## Reaction Pathway

- Excitation:
- Energy Transfer: The excited uranyl ion transfers energy to the oxalate ion ( ).
- Decomposition: The oxalate decomposes into carbon dioxide, carbon monoxide, and water, while the uranyl ion returns to its ground state (mostly conserved, though slight reduction can occur).

Key Characteristic: The quantum yield (

) is roughly 0.5–0.6 across the UV spectrum.<sup>[1]</sup> It is temperature-dependent but relatively insensitive to intensity variations, making it robust for high-flux lasers.

## Comparative Data Analysis

The following data synthesizes inter-laboratory measurements from the classic Leighton & Forbes studies through to modern IUPAC harmonized values (Kuhn et al., 2004).

### Table 1: Quantum Yield ( ) Comparison

Note: Uranyl Oxalate values are for 0.01 M Uranyl Sulfate / 0.05 M Oxalic Acid.

Wavelength ( )	Uranyl Oxalate (Standard)	Potassium Ferrioxalate (Alternative)	Relative Sensitivity
254 nm	0.60 ± 0.03	1.25 ± 0.02	Ferrioxalate is ~2.1x more sensitive
313 nm	0.56 ± 0.02	1.24 ± 0.02	Ferrioxalate is ~2.2x more sensitive
365 nm	0.49 ± 0.02	1.21 ± 0.02	Ferrioxalate is ~2.5x more sensitive
405 nm	0.30 ± 0.03	1.14 ± 0.02	Ferrioxalate is ~3.8x more sensitive
436 nm	0.58 (Inconsistent)*	1.01 ± 0.02	Uranyl reliability drops significantly

\*Note: At >400nm, Uranyl Oxalate absorption drops, leading to higher inter-lab variability due to inner filter effects and low optical density.

## Table 2: Operational Constraints & Error Sources

Parameter	Uranyl Oxalate	Potassium Ferrioxalate
Primary Error Source	Titration Accuracy: Relies on differential titration of oxalate (small difference between two large numbers).	Handling: Extremely sensitive to ambient visible light (requires darkroom).
Safety Profile	High Risk: Uranium is radioactive and chemically toxic (nephrotoxic).	Moderate Risk: Light sensitive, but chemically less hazardous.
Solution Stability	Excellent: Stable in dark for months.	Poor: Must be prepared fresh; thermal instability.[2]
Analysis Method	Titrimetry (Permanganate/Cerium) or HPLC.	Spectrophotometry (Complexation with phenanthroline).

## Inter-Laboratory Variability Analysis

Historically, discrepancies in Uranyl Oxalate

values (ranging from 0.50 to 0.62 at similar wavelengths) have been traced to three critical variables. Understanding these allows you to minimize error.

- Purity of Uranyl Salts: Early 20th-century studies often used commercial Uranyl Sulfate with varying hydration states. Modern Protocol: Recrystallization of reagents is mandatory. Impurities act as inner filters, absorbing photons without initiating the oxalate decomposition, artificially lowering
  - The Differential Titration Problem: The actinometer measures the loss of oxalate.
    - Scenario: You start with 0.05 M oxalate.[3] After irradiation, you have 0.045 M.
    - The Issue: You are measuring a small difference (0.005 M) by subtracting two large numbers. A 1% error in titration volume results in a ~10% error in the calculated photon flux.

- Correction: Use weight burettes or modern HPLC methods to quantify oxalate loss with high precision.
- pH and Temperature Dependence: Unlike Ferrioxalate, Uranyl Oxalate has a non-negligible temperature coefficient. Inter-lab comparisons show that labs failing to thermostatically control the cell at 25°C report deviations of  $\pm 2-3\%$  per 10°C shift.

## Visualization: Decision & Workflow

### Diagram 1: Selection Logic (Actinometer Choice)

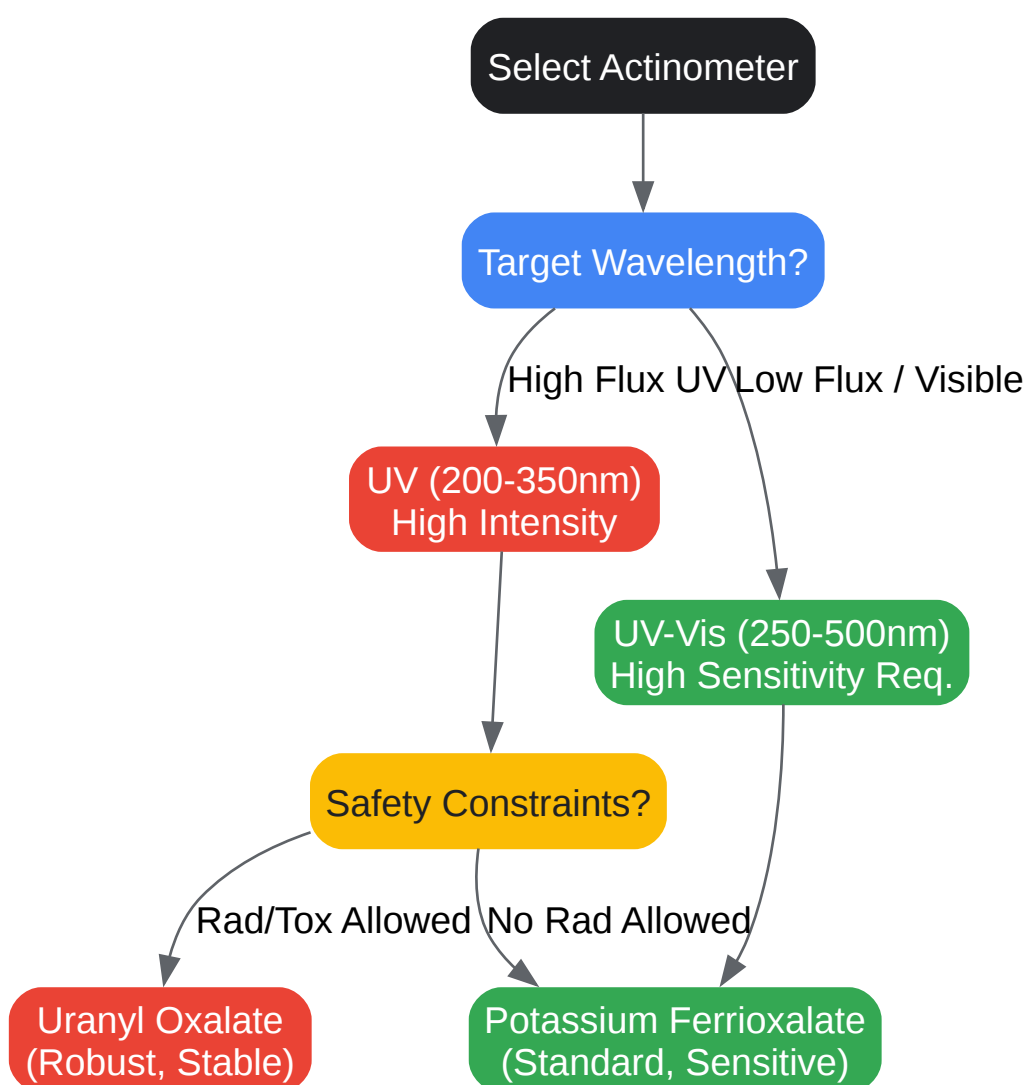

[Click to download full resolution via product page](#)

Caption: Logical decision matrix for selecting between Uranyl Oxalate and Ferrioxalate based on wavelength and safety constraints.

## Diagram 2: The Self-Validating Protocol (Uranyl Oxalate)

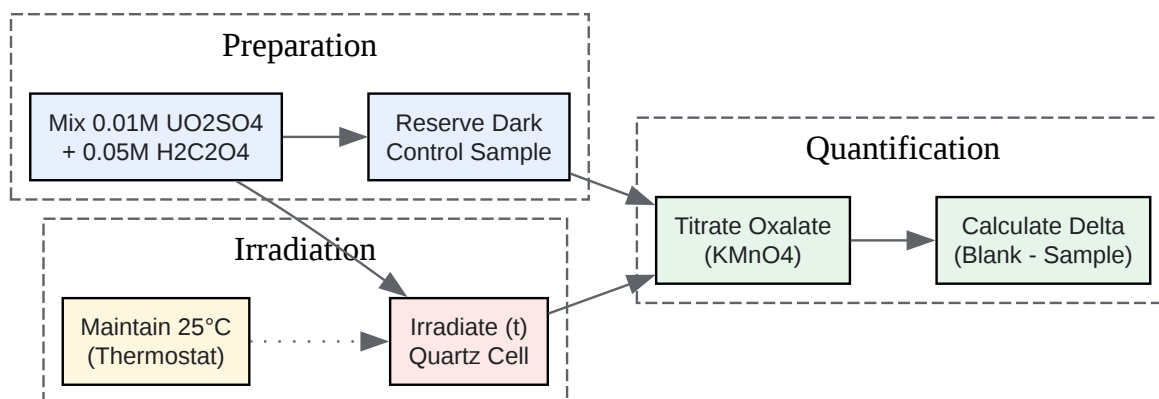

[Click to download full resolution via product page](#)

Caption: Step-by-step experimental workflow ensuring subtraction of dark control for accurate differential analysis.

## Standardized Experimental Protocol

Objective: Determine photon flux (

) using the Uranyl Oxalate system. Reference: IUPAC Technical Report (Kuhn et al., 2004).[4]  
[5][6][7]

### Reagents

- Uranyl Sulfate ( ): Must be recrystallized.
- Oxalic Acid ( ): Analytical grade.
- Potassium Permanganate (

): 0.02 M standardized solution.

## Step-by-Step Methodology

- Preparation (Darkroom not required, but avoid direct sunlight):
  - Prepare 1 L of solution containing 3.76 g Uranyl Sulfate (0.01 M) and 6.3 g Oxalic Acid (0.05 M).
  - Self-Validation Step: Titrate three 10 mL aliquots immediately to establish the initial oxalate concentration ( ). Precision must be within  $\pm 0.5\%$ .
- Irradiation:
  - Place exactly (e.g., 10 mL) of the actinometer solution into a quartz cuvette.
  - Irradiate for time (seconds).[1][2]
  - Critical: Ensure stirring during irradiation to prevent local depletion of oxalate at the cuvette window.[8]
- Analysis (Permanganate Titration):
  - Transfer the irradiated solution to a flask.
  - Add 20 mL of dilute sulfuric acid (2 M) and heat to 60°C.
  - Titrate with standardized to a faint pink endpoint.
  - Repeat with the non-irradiated "Dark Control" ( ).

- Calculation: Calculate the incident photon flux ( ) using the formula:
  - : Moles of oxalate consumed.
  - : Quantum yield at specific wavelength (Use 0.57 for broadband UV approx, or specific values from Table 1).
  - : Fraction of light absorbed (Usually for Uranyl Oxalate in UV).

## References

- Kuhn, H. J., Braslavsky, S. E., & Schmidt, R. (2004).<sup>[4][6][7]</sup> Chemical Actinometry (IUPAC Technical Report). Pure and Applied Chemistry, 76(12), 2105–2146.<sup>[7][9]</sup> [\[Link\]](#)<sup>[5][7]</sup>
- Hatchard, C. G., & Parker, C. A. (1956). A New Sensitive Chemical Actinometer. II. Potassium Ferrioxalate as a Standard Chemical Actinometer.<sup>[2][10][11]</sup> Proceedings of the Royal Society of London. Series A, 235(1203), 518–536. [\[Link\]](#)
- Leighton, P. A., & Forbes, G. S. (1930). Precision Actinometry with Uranyl Oxalate. Journal of the American Chemical Society, 52(8), 3139–3152. [\[Link\]](#)
- Montalti, M., Credi, A., Prodi, L., & Gandolfi, M. T. (2006). Handbook of Photochemistry (3rd ed.). CRC Press. (Chapter: Chemical Actinometry). [\[Link\]](#)

### Need Custom Synthesis?

BenchChem offers custom synthesis for rare earth carbides and specific isotopic labeling.

Email: [info@benchchem.com](mailto:info@benchchem.com) or [Request Quote Online](#).

## Sources

- [1. pdf.benchchem.com \[pdf.benchchem.com\]](#)
- [2. pdf.benchchem.com \[pdf.benchchem.com\]](#)

- [3. m.youtube.com \[m.youtube.com\]](https://m.youtube.com)
- [4. semanticscholar.org \[semanticscholar.org\]](https://semanticscholar.org)
- [5. kgroupp.du.edu \[kgroupp.du.edu\]](https://kgroup.du.edu)
- [6. old.iupac.org \[old.iupac.org\]](https://old.iupac.org)
- [7. publications.iupac.org \[publications.iupac.org\]](https://publications.iupac.org)
- [8. datapdf.com \[datapdf.com\]](https://datapdf.com)
- [9. researchgate.net \[researchgate.net\]](https://researchgate.net)
- [10. researchgate.net \[researchgate.net\]](https://researchgate.net)
- [11. researchgate.net \[researchgate.net\]](https://researchgate.net)
- To cite this document: BenchChem. [Comparative Guide: Uranyl Oxalate Actinometry in High-Precision Photochemistry]. BenchChem, [2026]. [Online PDF]. Available at: [\[https://www.benchchem.com/product/b12653824/docs#comparative-guide-uranyl-oxalate-actinometry-in-high-precision-photochemistry\]](https://www.benchchem.com/product/b12653824/docs#comparative-guide-uranyl-oxalate-actinometry-in-high-precision-photochemistry)

---

### Disclaimer & Data Validity:

The information provided in this document is for Research Use Only (RUO) and is strictly not intended for diagnostic or therapeutic procedures. While BenchChem strives to provide accurate protocols, we make no warranties, express or implied, regarding the fitness of this product for every specific experimental setup.

**Technical Support:** The protocols provided are for reference purposes. Unsure if this reagent suits your experiment?

**Need Industrial/Bulk Grade?** [Request Custom Synthesis Quote](#)

## BenchChem

Our mission is to be the trusted global source of essential and advanced chemicals, empowering scientists and researchers to drive progress in science and industry.

### Contact

Address: 3281 E Guasti Rd  
Ontario, CA 91761, United States  
Phone: (601) 213-4426  
Email: [info@benchchem.com](mailto:info@benchchem.com)

Contact our Ph.D. Support Team for a compatibility check