

improving the yield of sulfonamide synthesis with unreactive anilines

Author: BenchChem Technical Support Team. **Date:** December 2025

Compound of Interest

Compound Name: 1-Butanesulfonyl chloride

Cat. No.: B1265866

[Get Quote](#)

Welcome to the Technical Support Center for Sulfonamide Synthesis. This guide is designed for researchers, scientists, and drug development professionals to troubleshoot and optimize the synthesis of sulfonamides, particularly when working with challenging, unreactive anilines.

Frequently Asked Questions (FAQs) & Troubleshooting Guides

Q1: Why is my sulfonamide synthesis yield consistently low when using an electron-deficient aniline?

A1: The primary cause of low yields is the reduced nucleophilicity of the aniline.^[1] Electron-withdrawing groups (EWGs) such as -NO₂, -CN, or -CF₃ on the aromatic ring decrease the electron density on the nitrogen atom.^[1] This makes the aniline's lone pair of electrons less available to attack the electrophilic sulfur atom of the sulfonyl chloride, resulting in a sluggish or incomplete reaction.^{[1][2]}

Troubleshooting Steps:

- **Increase Reaction Temperature:** Carefully increasing the reaction temperature can provide the necessary activation energy for the reaction to proceed. However, monitor for potential decomposition of starting materials or products.^[2]
- **Use a More Forcing Solvent:** Switching to a higher-boiling point solvent can facilitate the reaction at elevated temperatures.

- **Employ a Catalyst:** The addition of a nucleophilic catalyst like 4-dimethylaminopyridine (DMAP) can significantly accelerate the reaction rate.[2] DMAP works by forming a more reactive sulfonyl-DMAP intermediate.[2]
- **Consider Alternative Reagents:** If the aniline is particularly unreactive, standard sulfonyl chlorides may not be suitable. Modern, more reactive reagents or alternative synthetic strategies may be required.[3]

Q2: I'm observing significant unreacted starting materials. What are the common causes?

A2: Unreacted starting materials are often the main "impurities" and point to several potential issues in the reaction setup and execution.[2]

Potential Causes & Solutions:

- **Hydrolysis of Sulfonyl Chloride:** Sulfonyl chlorides are highly susceptible to moisture, hydrolyzing to the corresponding unreactive sulfonic acid.[2][4]
 - **Solution:** Ensure all glassware is oven-dried or flame-dried before use. Use anhydrous solvents and conduct the reaction under an inert atmosphere (e.g., Nitrogen or Argon).[2][5]
- **Insufficient Base:** The reaction generates hydrochloric acid (HCl), which protonates the aniline, rendering it non-nucleophilic and stopping the reaction.[5]
 - **Solution:** Ensure at least one stoichiometric equivalent of a suitable base is used to neutralize the HCl produced.[5] For unreactive anilines, a stronger, non-nucleophilic base may be beneficial.[1]
- **Poor Reagent Quality:** Old or improperly stored sulfonyl chloride may have already hydrolyzed.[4]
 - **Solution:** Use a fresh bottle of the sulfonylating agent or purify the existing reagent. Store sulfonyl chlorides in a desiccator under an inert atmosphere.[4]
- **Reaction Has Stalled:** The activation energy may be too high under the current conditions.

- Solution: Monitor the reaction by Thin Layer Chromatography (TLC) or Liquid Chromatography-Mass Spectrometry (LC-MS). If it has stalled, consider extending the reaction time or cautiously increasing the temperature.[5]

Q3: What are the best strategies and alternative reagents for coupling with poorly nucleophilic anilines?

A3: For challenging electron-deficient or sterically hindered anilines, more advanced or alternative methods are often necessary.[6] Standard conditions with sulfonyl chlorides may fail or give very low yields.[7]

Modern Strategies & Reagents:

- Use of Sulfonyl Fluorides: Sulfonyl fluorides are often more stable than sulfonyl chlorides and can provide better yields, especially with anilines bearing other functional groups.[2] Their reaction can be promoted by Lewis acids like $\text{Ca}(\text{NTf}_2)_2$. [8][9]
- SO_2 Surrogates (e.g., DABSO): 1,4-Diazabicyclo[2.2.2]octane bis(sulfur dioxide) (DABSO) is a stable, solid alternative to gaseous SO_2 . [10] It can be used in multi-component, copper-catalyzed reactions with aryl boronic acids and amines to form sulfonamides under mild conditions. [3][10]
- Catalytic Oxidation Methods: These methods involve the oxidative coupling of a sulfur source (like thiols or sodium arylsulfonates) with the aniline. [3] This avoids the need to pre-form a sulfonyl chloride.
- Photoredox and Copper Co-catalysis: Recent methods leverage photoredox and copper catalysis for the synthesis of sulfonamides from various aryl radical precursors, amines, and a sulfur dioxide source. This one-step process is effective for both electron-rich and electron-deficient amines. [10]

Data Presentation: Comparison of Methods & Reagents

Table 1: Comparison of Common Bases for Sulfonylation

| Base | Type | Common Use | Advantages | Disadvantages |
|---------------------|-------------------------------|---|--|---|
| Pyridine | Nucleophilic Base/Catalyst | Often used as both base and solvent.[4] | Acts as a nucleophilic catalyst.[4] | Excess or high temperatures can lead to byproducts.[4] |
| Triethylamine (TEA) | Non-nucleophilic Base | Standard HCl scavenger.[4] | Readily available, effective HCl scavenger. | Can be insufficient for deprotonating weakly acidic anilines. |
| DIPEA | Non-nucleophilic Base | Used for sterically hindered substrates. | More hindered than TEA, reducing side reactions. | More expensive than TEA. |
| DMAP (catalytic) | Nucleophilic Catalyst | Used in catalytic amounts with a stoichiometric base (e.g., TEA). [4] | Significantly accelerates reactions, especially with unreactive substrates.[2] | Can be difficult to remove during purification. |
| NaOtBu / KOtBu | Strong, Non-nucleophilic Base | Essential for challenging couplings like Buchwald-Hartwig amination.[1] | Strong enough to deprotonate weakly acidic N-H bonds.[1] | Highly basic, may not be compatible with sensitive functional groups. |

Table 2: Alternative Sulfonylating Agents and SO₂ Surrogates

| Reagent Type | Examples | Starting Materials | Key Advantages | Considerations |
|----------------------------|---------------------------------|---|---|---|
| Sulfonyl Fluorides | Ar-SO ₂ F | Amines | Good reactivity, more stable than sulfonyl chlorides.[2] | Availability may be limited; often requires activation with a Lewis acid.[3][8] |
| SO ₂ Surrogates | DABSO | Aryl Boronic Acids, Amines | Stable, safe, and versatile solid source of SO ₂ . [3] Enables multi-component reactions.[10] | Reaction requires a catalyst (e.g., Copper) and optimization.[3][10] |
| Sulfinic Acids/Salts | Sodium Arylsulfinates | Amines | Stable and easy-to-handle sulfur source.[3] | Often requires an oxidant for the coupling reaction.[3] |
| Thiols | Aryl Thiols | Amines | Direct conversion under mild, often metal-free conditions.[3][10] | Thiols can be malodorous; reaction requires an oxidant.[3] |
| Organometallic Reagents | Grignard/Organolithium Reagents | N-Sulfinyl-O-(tert-butyl)hydroxylamine (t-BuONSO) | Direct, one-step synthesis of primary sulfonamides with high functional group tolerance.[11] | Requires inert atmosphere and anhydrous conditions.[3] |

Visualizations: Workflows and Mechanisms

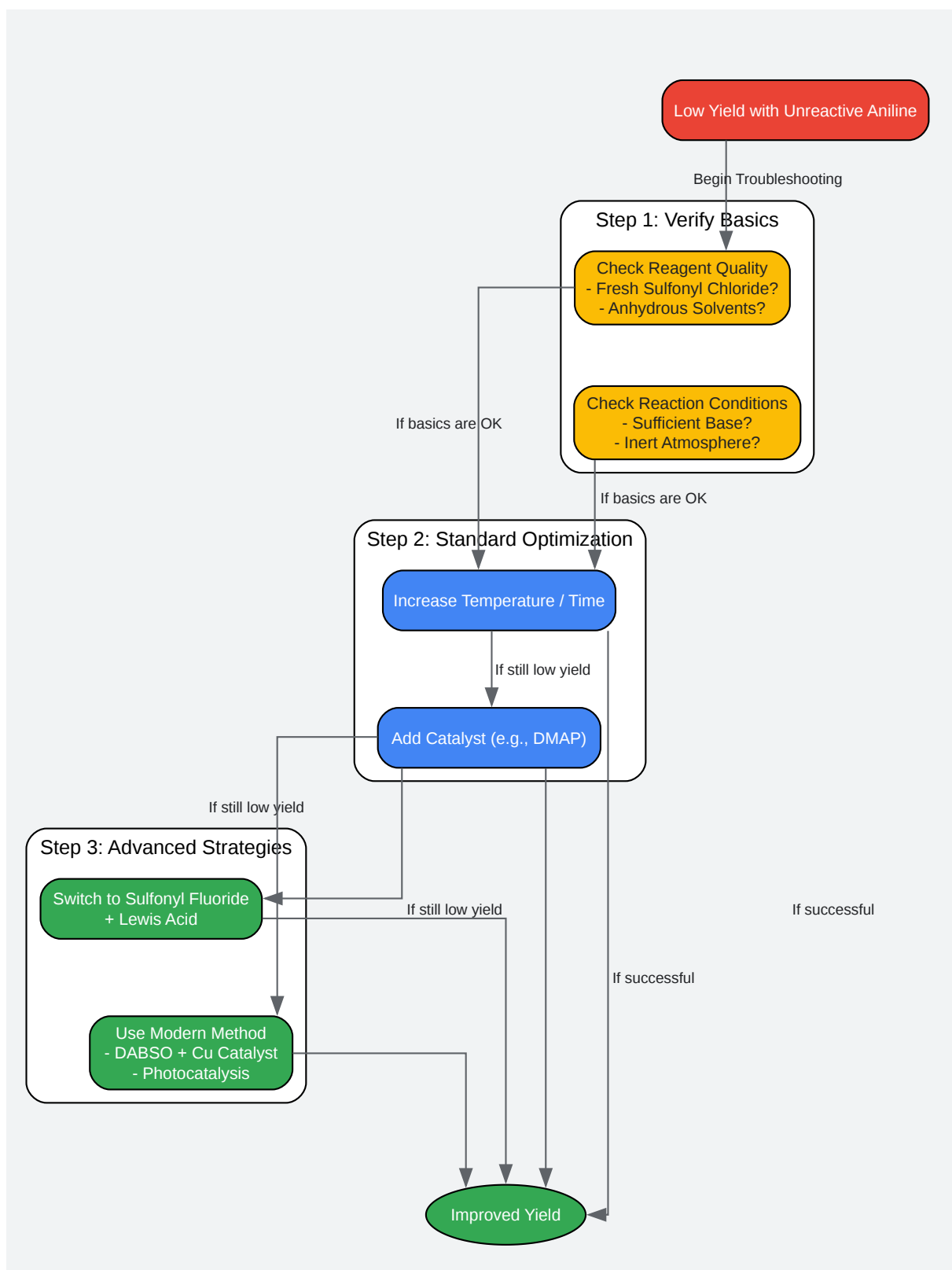

[Click to download full resolution via product page](#)

Caption: Troubleshooting workflow for low-yield sulfonamide synthesis.

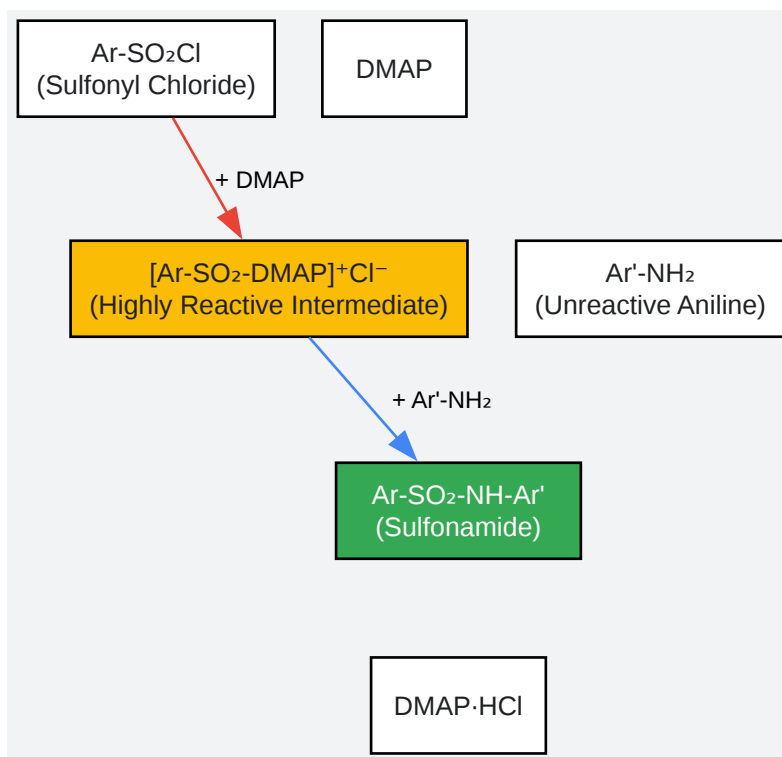

[Click to download full resolution via product page](#)

Caption: Catalytic mechanism of DMAP in sulfonamide synthesis.

Experimental Protocols

Protocol 1: General Procedure for Sulfonylation using Triethylamine

This protocol is a standard method for the synthesis of sulfonamides from anilines and sulfonyl chlorides.^[4]

- Preparation: In a flame-dried, round-bottom flask under an inert atmosphere (N₂ or Ar), dissolve the aniline (1.0 equiv.) in anhydrous dichloromethane (DCM) to a concentration of 0.1-0.5 M.
- Cooling: Place the flask in an ice bath (0 °C).
- Base Addition: Add triethylamine (Et₃N, 1.5 equiv.) to the solution and stir.

- **Sulfonyl Chloride Addition:** In a separate flask, dissolve the sulfonyl chloride (1.1 equiv.) in a minimal amount of anhydrous DCM. Add this solution dropwise to the stirred aniline solution over 10-15 minutes.
- **Reaction:** Allow the reaction to warm to room temperature and stir for 2-16 hours. Monitor the reaction progress by TLC or LC-MS.
- **Workup:** Upon completion, dilute the reaction mixture with DCM. Wash the organic layer sequentially with 1M HCl (to remove excess amine and base), saturated aqueous NaHCO₃, and brine.
- **Purification:** Dry the organic layer over anhydrous Na₂SO₄, filter, and concentrate under reduced pressure. Purify the crude product by flash column chromatography or recrystallization.[4]

Protocol 2: Copper-Catalyzed Sulfonamide Synthesis using DABSO

This protocol is an alternative for unreactive anilines, utilizing a boronic acid and a stable SO₂ surrogate.[3]

- **Preparation:** To a reaction vessel, add the arylboronic acid (1.0 mmol), the aniline (1.2 mmol), DABSO (0.6 mmol), and a copper catalyst (e.g., Cu(OAc)₂, 10 mol%).
- **Solvent Addition:** Add a suitable solvent (e.g., DMSO, 2 mL).
- **Reaction:** Stir the reaction mixture at a specified temperature (e.g., 80 °C) for a designated time (e.g., 12 hours) under an air atmosphere.
- **Workup:** Upon completion (monitored by TLC or LC-MS), quench the reaction with water.
- **Extraction & Purification:** Extract the product with an organic solvent (e.g., ethyl acetate). Combine the organic layers, dry over anhydrous Na₂SO₄, filter, and concentrate. Purify the crude product by flash column chromatography.[3]

Need Custom Synthesis?

BenchChem offers custom synthesis for rare earth carbides and specific isotopic labeling.

Email: info@benchchem.com or [Request Quote Online](#).

References

- 1. benchchem.com [benchchem.com]
- 2. benchchem.com [benchchem.com]
- 3. benchchem.com [benchchem.com]
- 4. benchchem.com [benchchem.com]
- 5. benchchem.com [benchchem.com]
- 6. benchchem.com [benchchem.com]
- 7. researchgate.net [researchgate.net]
- 8. pubs.acs.org [pubs.acs.org]
- 9. Sulfonamide synthesis by S-N coupling [organic-chemistry.org]
- 10. thieme-connect.com [thieme-connect.com]
- 11. pubs.acs.org [pubs.acs.org]
- To cite this document: BenchChem. [improving the yield of sulfonamide synthesis with unreactive anilines]. BenchChem, [2025]. [Online PDF]. Available at: [https://www.benchchem.com/product/b1265866#improving-the-yield-of-sulfonamide-synthesis-with-unreactive-anilines]

Disclaimer & Data Validity:

The information provided in this document is for Research Use Only (RUO) and is strictly not intended for diagnostic or therapeutic procedures. While BenchChem strives to provide accurate protocols, we make no warranties, express or implied, regarding the fitness of this product for every specific experimental setup.

Technical Support: The protocols provided are for reference purposes. Unsure if this reagent suits your experiment? [[Contact our Ph.D. Support Team for a compatibility check](#)]

Need Industrial/Bulk Grade? [Request Custom Synthesis Quote](#)

BenchChem

Our mission is to be the trusted global source of essential and advanced chemicals, empowering scientists and researchers to drive progress in science and industry.

Contact

Address: 3281 E Guasti Rd
Ontario, CA 91761, United States
Phone: (601) 213-4426
Email: info@benchchem.com