

Technical Support Center: sEH Assay Optimization

Author: BenchChem Technical Support Team. **Date:** April 2026

Compound of Interest

Compound Name: *1-Propylimidazolidine-2,4,5-trione*

CAS No.: 40408-38-6

Cat. No.: B1265992

[Get Quote](#)

Status: Operational Subject: Troubleshooting Hydrophobic Compound Precipitation in sEH Inhibition Screens

Introduction: The "Grease" Problem in sEH Screening

Soluble Epoxide Hydrolase (sEH) is a primary target for treating inflammation, hypertension, and pain. However, the most potent sEH inhibitors (sEHI)—typically 1,3-disubstituted ureas like AUDA, TPPU, and t-AUCB—are notoriously lipophilic. They possess high melting points and low aqueous solubility, often behaving more like "grease" than soluble drugs in aqueous buffers.

In high-throughput screening (HTS), this leads to a common failure mode: Compound Precipitation. This results in light scattering (false signals), "flat" dose-response curves, or complete loss of potency, leading researchers to discard potentially valuable hits.

This guide provides the protocols and mechanistic adjustments required to keep these lipophilic compounds in solution without compromising enzymatic kinetics.

Module 1: Diagnosis – Is it Inhibition or Precipitation?

Before altering your buffer, you must confirm that the assay failure is due to solubility limits.

Q: How do I distinguish between a non-binder and a precipitated compound? A: A non-binder yields a flat line at 100% activity. A precipitated compound often yields erratic data or a "false floor."

Diagnostic Indicators:

Symptom	Probable Cause	Verification Step
Steep Hill Slope	Aggregation/Precipitation	If Hill Slope > 2.0 or < -2.0, the compound is likely micellizing or crashing out.
High Background (RFU)	Light Scattering	Measure absorbance at 650 nm (nephelometry). If OD > 0.05, particles are scattering light.
"Flat" Top/Bottom	Solubility Limit Reached	The curve plateaus before reaching 0% or 100% activity because the compound cannot dissolve at higher concentrations.

| Time-Dependent Loss | Crystal Growth | Potency decreases over 30 mins as micro-crystals grow and sediment. |

Module 2: The Solvent System & Additives

Q: Can I just increase DMSO to keep the compound soluble? A: Only up to a point. While sEH is relatively robust, excessive DMSO alters the enzyme's kinetic parameters (

and

).

- The Limit: Keep final DMSO concentration $\leq 1\%$ (v/v).
- The Risk: Above 1%, DMSO can competitively inhibit sEH or alter the fluorophore's quantum yield (if using PHOME or CMNPC substrates).

Q: What is the "Gold Standard" additive strategy? A: You must use a carrier protein or a non-ionic detergent. The Hammock Lab (UC Davis) and Cayman Chemical protocols recommend Bovine Serum Albumin (BSA).

Comparative Additive Strategy

Additive	Concentration	Mechanism	Trade-off
BSA (Standard)	0.1 mg/mL	Acts as a "sponge," binding lipophilic drugs to keep them in the aqueous phase.	Right-Shifted IC50: BSA binds the inhibitor, reducing free drug concentration. You measure "Apparent IC50."
Pluronic F-127	0.01% - 0.05%	Non-ionic surfactant. [1][2] Coats hydrophobic molecules to prevent aggregation.	Can form micelles at high concentrations (>0.1%), trapping the drug entirely.
Tween-20	0.01%	Reduces surface tension.	Less effective than Pluronic for urea-based sEH inhibitors; high risk of bubbles in HTS.



Critical Recommendation: If using BSA, you must report values as "IC50 in the presence of 0.1 mg/mL BSA." For pure potency (Ki), you may need to mathematically correct for protein binding or validate with a detergent-only (BSA-free) assay.

Module 3: The "Step-Down" Dilution Protocol

The Error: Pipetting 100% DMSO stock directly into the aqueous assay buffer. The Consequence: The "Solvent Shock." The compound encounters water instantly, supersaturates locally, and crashes out before it can disperse.

The Solution: Use an Intermediate Dilution Plate to smooth the transition from organic to aqueous phase.

Protocol: 3-Step Serial Dilution

- Step 1: Master Stock (100% DMSO)
 - Prepare your compounds at 100x the final assay concentration in pure DMSO.
 - Example: For a 10 μ M final assay, prepare 1 mM stock.
- Step 2: Intermediate Plate (10% DMSO)
 - Prepare a "Transition Buffer": Assay Buffer + 0.1 mg/mL BSA.
 - Dilute the Master Stock 1:10 into the Transition Buffer.
 - Crucial: Vortex immediately upon addition.
 - Result: Compound is now at 10x concentration in 10% DMSO. The BSA begins to sequester the lipophilic molecules.
- Step 3: Assay Plate (1% DMSO)

- Add 10 μL of the Intermediate solution to 90 μL of the final reaction mix (Enzyme + Substrate).
- Final Conditions: 1x Compound, 1% DMSO, 0.1 mg/mL BSA.

Module 4: Visualization of Workflows

Figure 1: The Solubility Pathway vs. The Crash-Out Trap

This diagram illustrates why direct addition fails and how the intermediate step protects the compound.

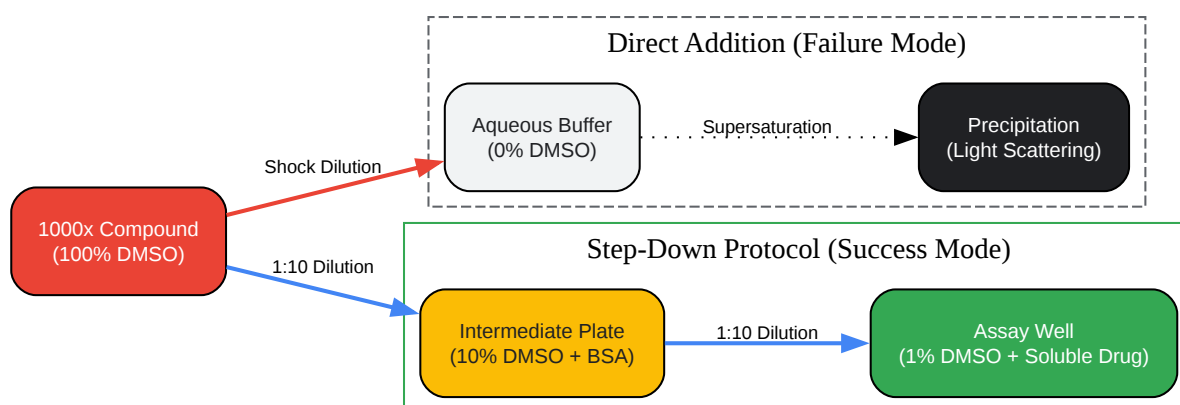

[Click to download full resolution via product page](#)

Caption: Figure 1. Comparison of direct addition (red path) leading to precipitation versus the intermediate step-down protocol (green path) which utilizes BSA and stepped DMSO gradients to maintain solubility.

Figure 2: Troubleshooting Decision Tree

Use this logic flow to determine the next step when data looks suspicious.

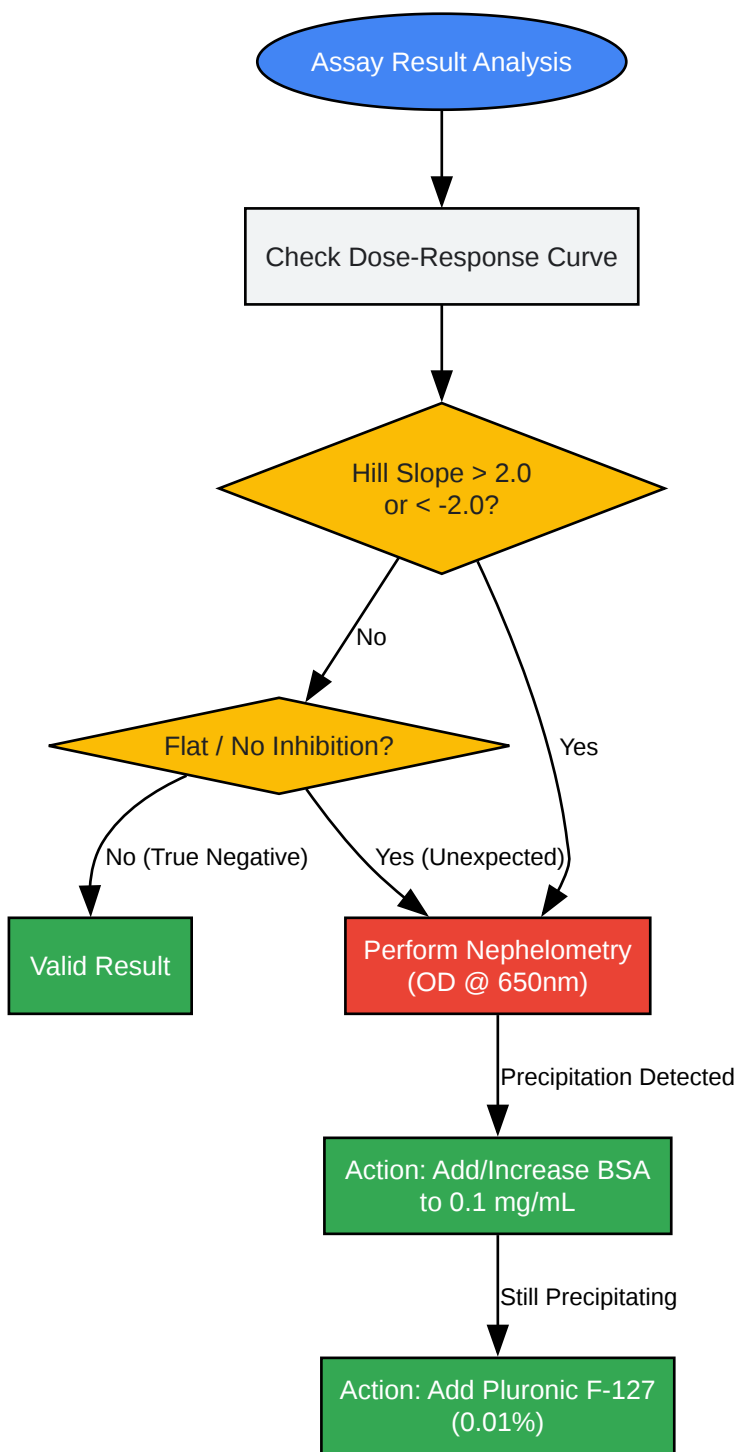

[Click to download full resolution via product page](#)

Caption: Figure 2. Decision logic for diagnosing solubility issues based on Hill Slope and optical density checks.

FAQ: Quick Solutions

Q: I am using the PHOME substrate (fluorescent). Does precipitation affect the reading? A: Yes. Precipitates scatter excitation light (330 nm), reducing the effective light reaching the fluorophore. This often looks like inhibition (lower signal), leading to false positives. Always verify "hits" with a secondary method (e.g., mass spectrometry) or by checking absorbance at 650 nm in the same well.

Q: Can I use mass spectrometry (LC-MS/MS) instead of fluorescence to avoid this? A: LC-MS/MS is the gold standard for sEH activity because it directly measures the conversion of substrate (e.g., 14,15-EET) to product (14,15-DHET). However, if the inhibitor precipitates, it still won't inhibit the enzyme. The advantage of MS is that it is less susceptible to optical interference, but it does not solve the solubility physics.

Q: My IC₅₀ shifted from 2 nM to 20 nM after adding BSA. Which is correct? A: Both are "correct" for their conditions. The 2 nM value (BSA-free) is likely closer to the intrinsic

, but the 20 nM value is more physiologically relevant because sEH operates in vivo in the presence of high protein concentrations.

References

- Cayman Chemical. Soluble Epoxide Hydrolase Inhibitor Screening Assay Kit Protocol. (Standardizes the use of Bis-Tris buffer and BSA additives).
- Morisseau, C., & Hammock, B. D. (2007).^[3] Measurement of soluble epoxide hydrolase (sEH) activity.^{[3][4][5][6][7][8]} Current Protocols in Toxicology.^{[3][9]} (The authoritative guide on sEH kinetics and solvent tolerance).
- Wolf, N. M., et al. (2006). Development of a high-throughput screen for soluble epoxide hydrolase inhibition. Analytical Biochemistry.^[5] (Details the optimization of DMSO limits and BSA concentrations for HTS).
- Lee, K. S. S., et al. (2014). Optimized Inhibitors of Soluble Epoxide Hydrolase Improve in Vitro Target Residence Time and in Vivo Efficacy. Journal of Medicinal Chemistry. (Discusses the physical properties and solubility challenges of urea-based inhibitors).

Need Custom Synthesis?

BenchChem offers custom synthesis for rare earth carbides and specific isotopic labeling.

Email: info@benchchem.com or [Request Quote Online](#).

Sources

- [1. documents.thermofisher.com](https://documents.thermofisher.com) [documents.thermofisher.com]
- [2. cdn.caymanchem.com](https://cdn.caymanchem.com) [cdn.caymanchem.com]
- [3. Measurement of soluble epoxide hydrolase \(sEH\) activity - PubMed](#) [pubmed.ncbi.nlm.nih.gov]
- [4. lcms.cz](https://lcms.cz) [lcms.cz]
- [5. cdn.caymanchem.com](https://cdn.caymanchem.com) [cdn.caymanchem.com]
- [6. Development of a high-throughput screen for soluble epoxide hydrolase inhibition - PMC](#) [pmc.ncbi.nlm.nih.gov]
- [7. cdn.caymanchem.com](https://cdn.caymanchem.com) [cdn.caymanchem.com]
- [8. pubs.acs.org](https://pubs.acs.org) [pubs.acs.org]
- [9. researchgate.net](https://researchgate.net) [researchgate.net]
- To cite this document: BenchChem. [Technical Support Center: sEH Assay Optimization]. BenchChem, [2026]. [Online PDF]. Available at: [<https://www.benchchem.com/product/b1265992/docs#technical-support-center-seh-assay-optimization>]

Disclaimer & Data Validity:

The information provided in this document is for Research Use Only (RUO) and is strictly not intended for diagnostic or therapeutic procedures. While BenchChem strives to provide accurate protocols, we make no warranties, express or implied, regarding the fitness of this product for every specific experimental setup.

Technical Support: The protocols provided are for reference purposes. Unsure if this reagent suits your experiment?

Need Industrial/Bulk Grade? [Request Custom Synthesis Quote](#)

BenchChem

Our mission is to be the trusted global source of essential and advanced chemicals, empowering scientists and researchers to drive progress in science and industry.

Contact

Address: 3281 E Guasti Rd
Ontario, CA 91761, United States
Phone: (601) 213-4426
Email: info@benchchem.com

[Contact our Ph.D. Support Team for a compatibility check](#)