

Technical Support Center: Optimizing the In Vivo Adjuvant Effect of 7DW8-5

Author: BenchChem Technical Support Team. **Date:** April 2026

Compound of Interest

Compound Name: 7DW8-5
Cat. No.: B1265247

[Get Quote](#)

Welcome to the technical support center for **7DW8-5**. This resource provides researchers, scientists, and drug development professionals with comprehensive troubleshooting guides and frequently asked questions (FAQs) to optimize the in vivo adjuvant effects of **7DW8-5**.

Frequently Asked Questions (FAQs)

Q1: What is **7DW8-5** and how does it exert its adjuvant effect?

A1: **7DW8-5** is a synthetic glycolipid analog of α -galactosylceramide (α -GalCer).[1][2] It functions as a potent vaccine adjuvant by activating invariant Natural Killer T (iNKT) cells.[1][2] This activation is not mediated through the STING pathway, but rather through the presentation of the glycolipid by the CD1d molecule on antigen-presenting cells (APCs) to the T-cell receptor of iNKT cells.[1][2][3] Activated iNKT cells then rapidly release a cascade of cytokines, such as IFN- γ , which promotes the maturation of dendritic cells and enhances both cellular (CD8+ T cell) and humoral (antibody) immune responses to co-administered antigens.[2][4][5][6]

Q2: What are the main advantages of **7DW8-5** over its parent compound, α -GalCer?

A2: **7DW8-5** has demonstrated significantly higher potency compared to α -GalCer. It can be up to 100- to 140-fold more active in stimulating both human and mouse iNKT cells.[1][2] This

increased potency allows for a dose-sparing effect, achieving a superior adjuvant effect at lower concentrations.[2][3]

Q3: What types of immune responses are enhanced by **7DW8-5**?

A3: **7DW8-5** is known to promote a robust Th1-biased immune response, characterized by the production of IFN- γ . [1][4] This leads to a significant enhancement of antigen-specific CD8+ T cell responses, which are crucial for clearing virally infected cells and cancer cells. [2][6][7] It also enhances humoral immunity, leading to increased production of antigen-specific antibodies. [2][8]

Q4: Is the adjuvant effect of **7DW8-5** dependent on the route of administration?

A4: Yes, the route of administration is critical for the adjuvant effect of **7DW8-5**. Studies have shown that intravenous (IV) and intradermal (ID) administration can induce potent systemic and localized immune responses, respectively. [4][9] In contrast, intramuscular (IM) administration may not produce a systemic cytokine spike but can still enhance local immune responses, particularly when co-localized with the antigen. [3][9] The choice of administration route should be tailored to the specific application and desired immune outcome.

Troubleshooting Guide

Issue	Possible Cause(s)	Recommended Solution(s)
<p>Low or no enhancement of antigen-specific T-cell response.</p>	<p>Suboptimal dose of 7DW8-5: The dose of 7DW8-5 may be too low to elicit a strong iNKT cell activation.</p>	<p>Dose Titration: Perform a dose-response study to determine the optimal concentration of 7DW8-5 for your specific model and antigen. Doses in mice have ranged from 10 µg/kg to 100 µg/kg.[1]</p>
<p>Inappropriate route of administration: The chosen route may not be optimal for inducing the desired T-cell response.</p>	<p>Optimize Administration Route: Compare different administration routes (e.g., intravenous, intradermal, intramuscular). Co-administration of 7DW8-5 and the antigen at the same site is often crucial for intramuscular injections.[9]</p>	
<p>Poor co-localization of 7DW8-5 and antigen: If administered separately, the adjuvant and antigen may not reach the same APCs in the draining lymph nodes.</p>	<p>Ensure Co-formulation/Co-administration: Whenever possible, formulate 7DW8-5 and the antigen together. If administered separately, inject them at the same site.[3][9]</p>	
<p>Sex-specific differences in immune response: Male mice have been shown to exhibit a significantly lower IFN-γ and IL-4 response to 7DW8-5 compared to female mice.[5]</p>	<p>Consider Sex of Animals: Be aware of potential sex-specific differences and consider including both male and female animals in your studies. Report data segregated by sex.[5]</p>	
<p>High variability in immune responses between animals.</p>	<p>Improper formulation or solubility of 7DW8-5: 7DW8-5 is a glycolipid and may require specific formulation to ensure</p>	<p>Optimize Formulation: A common method for solubilizing 7DW8-5 is to first dissolve it in a solution</p>

	proper solubilization and bioavailability.	containing a surfactant like Tween-80 before diluting in a physiologically compatible buffer like PBS.[10]
Inconsistent administration technique: Variations in injection volume or depth can lead to inconsistent delivery and uptake.	Standardize Administration Protocol: For intradermal injections, using an ultra-low volume (e.g., 2.5 µL) has been shown to be effective and dose-sparing.[4][11] Ensure all personnel are trained on a standardized injection technique.	
Unexpected systemic toxicity or adverse effects.	High dose of 7DW8-5: While generally well-tolerated, high doses may lead to transient systemic cytokine release.	Dose Reduction: If adverse effects are observed, reduce the dose of 7DW8-5. The high potency of 7DW8-5 often allows for effective adjuvanticity at lower, well-tolerated doses.[2]
Route of administration: Intravenous administration is more likely to cause a systemic cytokine spike compared to intramuscular or intradermal routes.[4][9]	Change Administration Route: Consider switching from IV to ID or IM administration to minimize systemic exposure. [4][9]	

Quantitative Data Summary

Table 1: In Vivo Dose-Response of **7DW8-5** in a Mouse Colitis Model

7DW8-5 Dose (µg/kg)	Change in Body Weight	Disease Activity Index (DAI) Score	Histologic Score
10	Improvement	Improvement	Improvement
50	Greater Improvement	Greater Improvement	Greater Improvement
100	Significant Improvement	Significant Improvement	Significant Improvement

Data summarized from a study on DSS-induced acute colitis in mice, demonstrating a dose-dependent protective effect of 7DW8-5.[1]

Table 2: Comparison of Adjuvant Effects of **7DW8-5** and α -GalCer on an Adenovirus-Vectored HIV Vaccine in Mice

Adjuvant (1 µg)	p24-specific CD8+ T-cell Response (IFN- γ ELISPOT)	Anti-p24 Antibody Titer (ELISA)
α -GalCer	~150 spots/10 ⁶ splenocytes	~1:1000
7DW8-5	>300 spots/10 ⁶ splenocytes	~1:2000

This table shows that 7DW8-5 induced a more than two-fold increase in the p24-specific CD8+ T-cell response compared to α -GalCer.[2]

Experimental Protocols

Protocol 1: In Vivo Evaluation of **7DW8-5** Adjuvant Effect with a Recombinant Adenovirus Vaccine

- Animal Model: BALB/c mice are a commonly used strain.[2]
- Vaccine and Adjuvant Preparation:
 - Dilute the recombinant adenovirus vaccine expressing the antigen of interest (e.g., Ad-p24) to a suboptimal dose in sterile PBS.
 - Prepare a stock solution of **7DW8-5**. For example, dissolve **7DW8-5** powder in PBS containing 10% Tween-80 to a concentration of 10 mg/mL.[10] Further dilute in PBS to the final desired concentration (e.g., 1 µg per dose).
 - For co-administration, mix the vaccine and **7DW8-5** solution immediately before injection.
- Immunization:
 - Administer the vaccine-adjuvant mixture via the desired route (e.g., intramuscularly into the tibialis anterior muscle).[9]
 - Include control groups receiving the vaccine alone, **7DW8-5** alone, and vehicle control.
- Immune Response Assessment:
 - At a specified time point post-immunization (e.g., 2 weeks), harvest spleens for cellular immunity analysis and collect serum for humoral immunity analysis.[2]
 - Cellular Immunity: Perform an IFN-γ ELISPOT assay to quantify the number of antigen-specific CD8+ T cells.[2] Stimulate 5×10^5 splenocytes with a specific peptide epitope of the antigen (e.g., 1 µg/mL) for 18 hours at 37°C.[4]
 - Humoral Immunity: Use an ELISA to determine the antigen-specific antibody titers in the serum.[2][8]

Visualizations

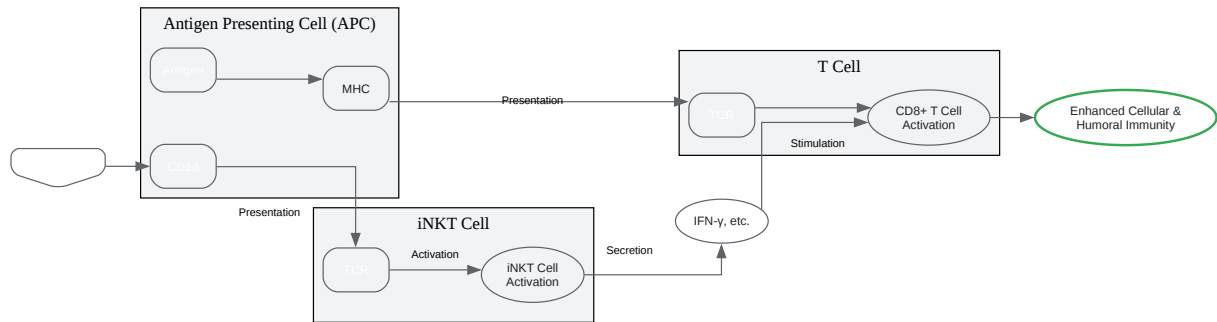

[Click to download full resolution via product page](#)

Caption: Mechanism of **7DW8-5** Adjuvant Action.

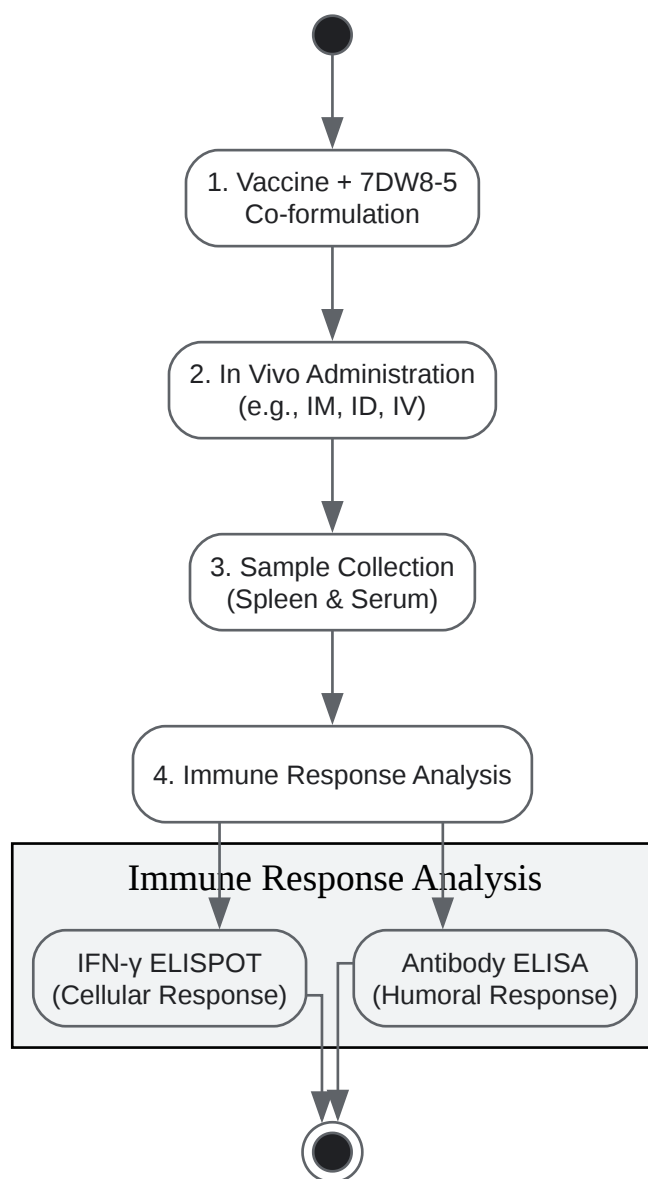

[Click to download full resolution via product page](#)

Caption: In Vivo Adjuvant Effect Evaluation Workflow.

Need Custom Synthesis?

BenchChem offers custom synthesis for rare earth carbides and specific isotopic labeling.

Email: info@benchchem.com or [Request Quote Online](#).

References

- 1. A glycolipid adjuvant, 7DW8-5, provides a protective effect against colonic inflammation in mice by the recruitment of CD1d-restricted natural killer T cells - PMC [[pmc.ncbi.nlm.nih.gov](https://pubmed.ncbi.nlm.nih.gov/)]
- 2. [pnas.org](https://pubmed.ncbi.nlm.nih.gov/) [[pnas.org](https://pubmed.ncbi.nlm.nih.gov/)]
- 3. Development of a novel mechanism-based glycolipid adjuvant for vaccination - PMC [[pmc.ncbi.nlm.nih.gov](https://pubmed.ncbi.nlm.nih.gov/)]
- 4. Ultra-low volume intradermal administration of radiation-attenuated sporozoites with the glycolipid adjuvant 7DW8-5 completely protects mice against malaria - PMC [[pmc.ncbi.nlm.nih.gov](https://pubmed.ncbi.nlm.nih.gov/)]
- 5. Sex-Specific Differences in Cytokine Induction by the Glycolipid Adjuvant 7DW8-5 in Mice - PMC [[pmc.ncbi.nlm.nih.gov](https://pubmed.ncbi.nlm.nih.gov/)]
- 6. A Glycolipid Adjuvant, 7DW8-5, Enhances CD8+ T Cell Responses Induced by an Adenovirus-Vectored Malaria Vaccine in Non-Human Primates - PMC [[pmc.ncbi.nlm.nih.gov](https://pubmed.ncbi.nlm.nih.gov/)]
- 7. A glycolipid adjuvant, 7DW8-5, enhances CD8+ T cell responses induced by an adenovirus-vectored malaria vaccine in non-human primates - PubMed [pubmed.ncbi.nlm.nih.gov]
- 8. Frontiers | A Glycolipid Adjuvant, 7DW8-5, Enhances the Protective Immune Response to the Current Split Influenza Vaccine in Mice [frontiersin.org]
- 9. researchgate.net [researchgate.net]
- 10. A Glycolipid α -GalCer Derivative, 7DW8-5 as a Novel Mucosal Adjuvant for the Split Inactivated Influenza Vaccine - PMC [[pmc.ncbi.nlm.nih.gov](https://pubmed.ncbi.nlm.nih.gov/)]
- 11. Ultra-low volume intradermal administration of radiation-attenuated sporozoites with the glycolipid adjuvant 7DW8-5 completely protects mice against malaria - PubMed [pubmed.ncbi.nlm.nih.gov]
- To cite this document: BenchChem. [Technical Support Center: Optimizing the In Vivo Adjuvant Effect of 7DW8-5]. BenchChem, [2026]. [Online PDF]. Available at: [<https://www.benchchem.com/product/b1265247/docs#technical-support-center-optimizing-the-in-vivo-adjuvant-effect-of-7dw8-5>]

Disclaimer & Data Validity:

The information provided in this document is for Research Use Only (RUO) and is strictly not intended for diagnostic or therapeutic procedures. While BenchChem strives to provide accurate protocols, we make no warranties, express or implied, regarding the fitness of this product for every specific experimental setup.

Technical Support: The protocols provided are for reference purposes. Unsure if this reagent suits your experiment?

Need Industrial/Bulk Grade? [Request Custom Synthesis Quote](#)

BenchChem

Our mission is to be the trusted global source of essential and advanced chemicals, empowering scientists and researchers to drive progress in science and industry.

Contact

Address: 3281 E Guasti Rd
Ontario, CA 91761, United States
Phone: (601) 213-4426
Email: info@benchchem.com

[Contact our Ph.D. Support Team for a compatibility check](#)