

Application Notes and Protocols for Testing the Efficacy of 7DW8-5

Author: BenchChem Technical Support Team. **Date:** April 2026

Compound of Interest

Compound Name: 7DW8-5
Cat. No.: B1265247

[Get Quote](#)

Introduction

7DW8-5 is a synthetic glycolipid analog of α -galactosylceramide (α -GalCer) that functions as a potent immune adjuvant.^{[1][2][3]} Its mechanism of action is centered on its high-affinity binding to the CD1d molecule on antigen-presenting cells (APCs), leading to the activation of invariant Natural Killer T (iNKT) cells.^{[1][4][5]} This interaction triggers a cascade of downstream immune responses, including the maturation of dendritic cells (DCs), activation of natural killer (NK) cells, and the promotion of a robust T-helper 1 (Th1)-biased cellular and humoral immune response, characterized by the production of interferon-gamma (IFN- γ) and enhanced CD8+ T cell activity.^{[1][2][6]} Preclinical studies have demonstrated its potential as an adjuvant for vaccines against infectious diseases such as malaria, HIV, and influenza, and as a therapeutic agent for inflammatory conditions like colitis.^{[4][7][8][9]}

These application notes provide a comprehensive experimental framework for researchers to evaluate the efficacy of **7DW8-5** in a preclinical setting. The protocols detailed below are designed to be adaptable to various disease models and research questions.

Key Experimental Objectives

- **In Vitro Characterization of 7DW8-5 Activity:** To confirm the bioactivity of **7DW8-5** by assessing its ability to activate iNKT cells and mature dendritic cells in vitro.
- **In Vivo Assessment of Immune Activation:** To determine the in vivo immunological effects of **7DW8-5**, including cytokine profiling and activation of key immune cell populations.
- **Evaluation of Adjuvant Efficacy in a Vaccination Model:** To test the ability of **7DW8-5** to enhance antigen-specific immune responses and protective efficacy in a relevant disease model (e.g., influenza vaccination).
- **Assessment of Therapeutic Efficacy in an Inflammatory Disease Model:** To investigate the potential of **7DW8-5** to ameliorate disease in a model of inflammatory bowel disease.

Data Presentation

All quantitative data from the following experiments should be summarized in clearly structured tables for easy comparison between experimental groups.

Table 1: In Vitro iNKT Cell Activation

Treatment Group	Concentration (ng/mL)	% CD69+ iNKT Cells (Mean ± SD)	IFN-γ Secretion (pg/mL) (Mean ± SD)	IL-4 Secretion (pg/mL) (Mean ± SD)
Vehicle Control	-			
7DW8-5	1			
7DW8-5	10			
7DW8-5	100			
α-GalCer (Positive Control)	100			

Table 2: In Vitro Dendritic Cell Maturation

Treatment Group	Concentration (ng/mL)	% CD80+ CD86+ DCs (Mean ± SD)	IL-12p70 Secretion (pg/mL) (Mean ± SD)
Vehicle Control	-		
7DW8-5	100		
LPS (Positive Control)	100		

Table 3: In Vivo Serum Cytokine Profile

Treatment Group	Time Point (hours)	IFN-γ (pg/mL) (Mean ± SD)	IL-4 (pg/mL) (Mean ± SD)	IL-12p70 (pg/mL) (Mean ± SD)
Vehicle Control	6			
7DW8-5	6			
Vehicle Control	24			
7DW8-5	24			

Table 4: Adjuvant Efficacy - Antigen-Specific T Cell and Antibody Responses

Treatment Group	Antigen-Specific CD8+ T Cells (% of total CD8+) (Mean ± SD)	Antigen-Specific IgG Titer (Mean ± SD)
Naive		
Antigen Only		
Antigen + Alum		
Antigen + 7DW8-5		

Table 5: Therapeutic Efficacy in DSS-Induced Colitis

Treatment Group	Disease Activity Index (DAI) (Mean \pm SD)	Colon Length (cm) (Mean \pm SD)	Histological Score (Mean \pm SD)
Healthy Control			
DSS + Vehicle			
DSS + 7DW8-5 (1 μ g)			
DSS + 7DW8-5 (10 μ g)			

Experimental Protocols

Protocol 1: In Vitro iNKT Cell Activation Assay

Objective: To determine the ability of **7DW8-5** to activate iNKT cells.

Methodology:

- Isolate splenocytes from wild-type mice.
- Plate splenocytes at a density of 2×10^5 cells/well in a 96-well plate.
- Treat cells with varying concentrations of **7DW8-5** (e.g., 1, 10, 100 ng/mL), α -GalCer (100 ng/mL) as a positive control, or vehicle control.
- Incubate for 48 hours at 37°C, 5% CO₂.
- After 24 hours, collect supernatant for cytokine analysis by ELISA (IFN- γ , IL-4).
- After 48 hours, harvest cells and stain for flow cytometry using antibodies against TCR β , PBS-57 loaded CD1d tetramer (to identify iNKT cells), and CD69 (an early activation marker).
- Acquire data on a flow cytometer and analyze the percentage of CD69+ iNKT cells.

Protocol 2: In Vitro Dendritic Cell Maturation Assay

Objective: To assess the effect of **7DW8-5** on dendritic cell maturation.

Methodology:

- Generate bone marrow-derived dendritic cells (BMDCs) from wild-type mice.
- Plate immature BMDCs at 1×10^6 cells/well in a 24-well plate.
- Treat cells with **7DW8-5** (100 ng/mL), LPS (100 ng/mL) as a positive control, or vehicle control.
- Incubate for 24 hours.
- Collect supernatant for IL-12p70 measurement by ELISA.
- Harvest cells and stain for flow cytometry using antibodies against CD11c, MHC Class II, CD80, and CD86.
- Analyze the expression of maturation markers (CD80, CD86) on the CD11c+ MHC Class II+ DC population.

Protocol 3: In Vivo Immune Activation and Cytokine Profiling

Objective: To measure the systemic cytokine response and immune cell activation following **7DW8-5** administration.

Methodology:

- Administer **7DW8-5** (e.g., 1 μ g) or vehicle control intravenously to a cohort of wild-type mice.
- At various time points (e.g., 2, 6, 12, 24 hours) post-injection, collect blood via retro-orbital or cardiac puncture.
- Isolate serum and measure cytokine levels (IFN- γ , IL-4, IL-12p70) using a multiplex cytokine assay or ELISA.

- At 24 hours post-injection, isolate splenocytes and stain for flow cytometry to analyze the activation status of NK cells (CD3- NK1.1+ CD69+) and dendritic cells (CD11c+ CD86+).

Protocol 4: Adjuvant Efficacy in an Influenza Vaccination Model

Objective: To evaluate the adjuvant effect of **7DW8-5** on a split influenza vaccine.[\[7\]](#)[\[8\]](#)

Methodology:

- On day 0, immunize mice intramuscularly with:
 - PBS (Naive)
 - Influenza vaccine (e.g., 0.1 µg HA) alone
 - Influenza vaccine + Alum (positive control adjuvant)
 - Influenza vaccine + **7DW8-5** (e.g., 1 µg)
- On day 14, administer a booster immunization with the same formulations.
- On day 28, collect blood to measure vaccine-specific IgG titers by ELISA.
- On day 28, isolate splenocytes and perform an IFN-γ ELISpot assay using a vaccine-specific peptide to enumerate antigen-specific CD8+ T cells.
- (Optional) On day 35, challenge mice with a lethal dose of influenza virus and monitor survival and weight loss for 14 days.

Protocol 5: Therapeutic Efficacy in a DSS-Induced Colitis Model

Objective: To assess the therapeutic potential of **7DW8-5** in a model of inflammatory bowel disease.[\[4\]](#)[\[10\]](#)

Methodology:

- Induce acute colitis in mice by administering 2.5% (w/v) dextran sulfate sodium (DSS) in the drinking water for 7 days.
- On day 2, 4, and 6, administer **7DW8-5** (e.g., 1 µg and 10 µg) or vehicle control intraperitoneally.
- Monitor mice daily for body weight, stool consistency, and presence of blood to calculate the Disease Activity Index (DAI).
- On day 8, euthanize the mice and collect the colon.
- Measure the colon length.
- Fix a portion of the distal colon in 10% buffered formalin for histological analysis (H&E staining) to assess inflammation and tissue damage.

Mandatory Visualizations

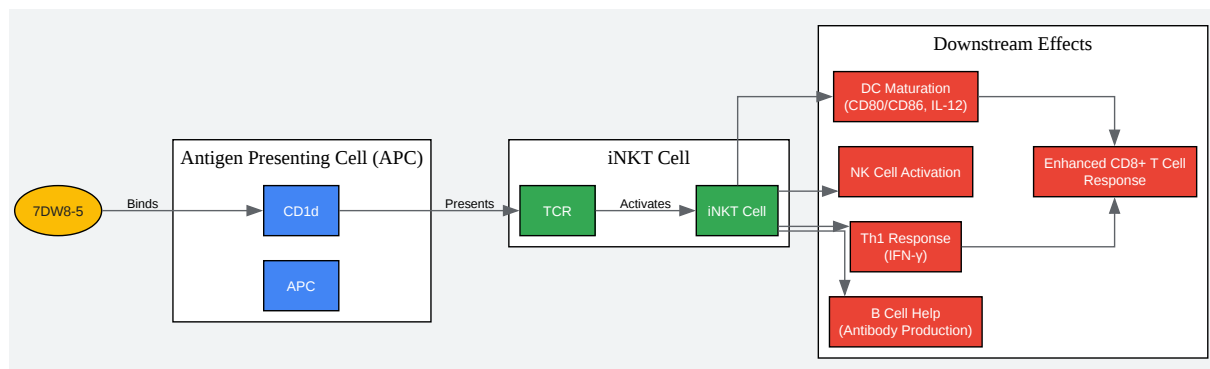

[Click to download full resolution via product page](#)

Caption: **7DW8-5** Signaling Pathway.

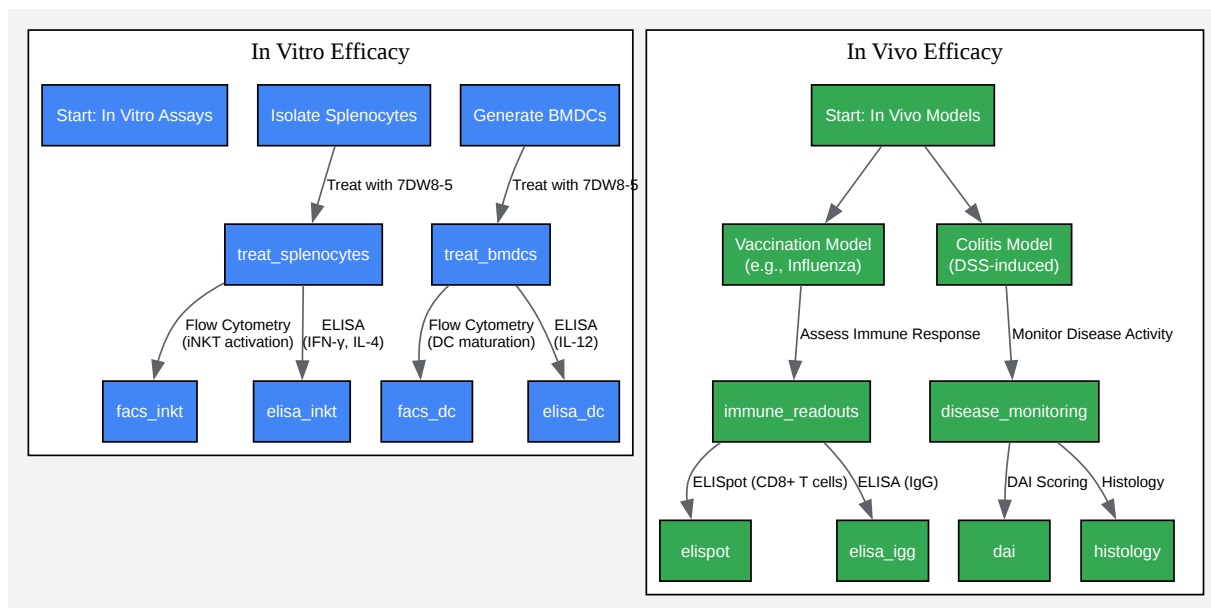

[Click to download full resolution via product page](#)

Caption: Experimental Workflow for **7DW8-5** Efficacy Testing.

Need Custom Synthesis?

BenchChem offers custom synthesis for rare earth carbides and specific isotopic labeling.

Email: info@benchchem.com or [Request Quote Online](#).

References

- 1. [researchgate.net](https://www.researchgate.net) [researchgate.net]
- 2. Sex-Specific Differences in Cytokine Induction by the Glycolipid Adjuvant 7DW8-5 in Mice - PMC [pmc.ncbi.nlm.nih.gov]

- [3. Development of a novel mechanism-based glycolipid... | F1000Research \[f1000research.com\]](#)
- [4. A glycolipid adjuvant, 7DW8-5, provides a protective effect against colonic inflammation in mice by the recruitment of CD1d-restricted natural killer T cells - PMC \[pmc.ncbi.nlm.nih.gov\]](#)
- [5. Development of a novel mechanism-based glycolipid adjuvant for vaccination - PMC \[pmc.ncbi.nlm.nih.gov\]](#)
- [6. A Glycolipid Adjuvant, 7DW8-5, Enhances CD8+ T Cell Responses Induced by an Adenovirus-Vectored Malaria Vaccine in Non-Human Primates - PMC \[pmc.ncbi.nlm.nih.gov\]](#)
- [7. researchgate.net \[researchgate.net\]](#)
- [8. mdpi.com \[mdpi.com\]](#)
- [9. pnas.org \[pnas.org\]](#)
- [10. A glycolipid adjuvant, 7DW8-5, provides a protective effect against colonic inflammation in mice by the recruitment of CD1d-restricted natural killer T cells - PubMed \[pubmed.ncbi.nlm.nih.gov\]](#)
- To cite this document: BenchChem. [Application Notes and Protocols for Testing the Efficacy of 7DW8-5]. BenchChem, [2026]. [Online PDF]. Available at: [\[https://www.benchchem.com/product/b1265247/docs#application-notes-and-protocols-for-testing-the-efficacy-of-7dw8-5\]](https://www.benchchem.com/product/b1265247/docs#application-notes-and-protocols-for-testing-the-efficacy-of-7dw8-5)

Disclaimer & Data Validity:

The information provided in this document is for Research Use Only (RUO) and is strictly not intended for diagnostic or therapeutic procedures. While BenchChem strives to provide accurate protocols, we make no warranties, express or implied, regarding the fitness of this product for every specific experimental setup.

Technical Support: The protocols provided are for reference purposes. Unsure if this reagent suits your experiment?

Need Industrial/Bulk Grade? [Request Custom Synthesis Quote](#)

BenchChem

Our mission is to be the trusted global source of essential and advanced chemicals, empowering scientists and researchers to drive progress in science and industry.

Contact

Address: 3281 E Guasti Rd

Ontario, CA 91761, United States

Phone: (601) 213-4426

Email: info@benchchem.com

[Contact our Ph.D. Support Team for a compatibility check](#)