

2-Bromo-2',5'-dimethoxyacetophenone molecular structure

Author: BenchChem Technical Support Team. **Date:** May 2026

Compound of Interest

Compound Name:	2-Bromo-2',5'- dimethoxyacetophenone
CAS No.:	1204-21-3
Cat. No.:	B1265504

[Get Quote](#)

An In-Depth Technical Guide to the Molecular Structure, Synthesis, and Application of **2-Bromo-2',5'-dimethoxyacetophenone**

Abstract

2-Bromo-2',5'-dimethoxyacetophenone is a versatile α -bromo ketone that serves as a pivotal intermediate in the fields of pharmaceutical development, medicinal chemistry, and materials science. Its unique molecular architecture, featuring a reactive brominated α -carbon and an electron-rich dimethoxy-substituted phenyl ring, endows it with a valuable chemical profile for constructing complex molecular scaffolds. This guide provides a comprehensive technical overview of its structural features, validated spectroscopic characterization methods, detailed synthesis protocols from common starting materials, and a discussion of its significant applications. By elucidating the causality behind experimental choices and mechanistic pathways, this document serves as a resource for researchers and drug development professionals aiming to leverage this compound in their synthetic endeavors.

Molecular Structure & Physicochemical Properties

Structural Elucidation

2-Bromo-2',5'-dimethoxyacetophenone, with the CAS Number 1204-21-3, is an acetophenone derivative.[1] Its structure is defined by a central ethanone core. One carbon of the ethyl group (the α -carbon) is substituted with a bromine atom, while the carbonyl group is attached to a 2,5-dimethoxyphenyl ring.

The key functional groups are:

- **α -Bromo Ketone:** This moiety is the center of the molecule's reactivity. The presence of the electron-withdrawing bromine atom and the adjacent carbonyl group makes the α -carbon highly electrophilic and susceptible to nucleophilic attack. The bromide ion is an excellent leaving group, facilitating various substitution reactions.[2]
- **Dimethoxy Phenyl Ring:** The two methoxy groups at the 2' and 5' positions are electron-donating, activating the aromatic ring towards certain electrophilic substitutions, although the primary reactivity of the molecule is dominated by the α -bromo ketone functionality.

Caption: Molecular structure of **2-Bromo-2',5'-dimethoxyacetophenone**.

Physicochemical & Spectroscopic Data

The identity and purity of **2-Bromo-2',5'-dimethoxyacetophenone** are confirmed through a combination of physical property measurements and spectroscopic analysis. It typically appears as a pale yellow or beige crystalline solid.[1][3]

Table 1: Physicochemical Properties

Property	Value	Reference(s)
CAS Number	1204-21-3	[1] [4]
Molecular Formula	C ₁₀ H ₁₁ BrO ₃	[1] [4] [5]
Molecular Weight	259.10 g/mol	[4] [5]
Appearance	Pale yellow / Beige solid	[1] [3] [6]
Melting Point	82 - 85 °C	[1] [6]
Purity	≥97% (HPLC)	[1] [5]
SMILES	<chem>COc1ccc(OC)c(c1)C(=O)CBr</chem>	

| InChIKey | RGQNFYVSEWDUEI-UHFFFAOYSA-N ||

Table 2: Spectroscopic Data Interpretation

Technique	Feature	Expected Chemical Shift / Frequency	Rationale
¹ H NMR	-CH ₂ Br	~4.6 ppm (s, 2H)	Protons on the α-carbon are significantly deshielded by the adjacent electron-withdrawing carbonyl group and the bromine atom. Appears as a singlet as there are no adjacent protons.[7]
	Ar-OCH ₃	~3.8-3.9 ppm (s, 6H)	Protons of the two methoxy groups are in a typical range for aryl methyl ethers.[7][8]
	Ar-H	~6.9-7.4 ppm (m, 3H)	Aromatic protons exhibit complex splitting patterns due to their positions on the substituted ring.[7]
¹³ C NMR	C=O (Ketone)	~185-195 ppm	The carbonyl carbon is highly deshielded, appearing far downfield.
	-CH ₂ Br	~30-40 ppm	The α-carbon is shifted downfield due to the attached bromine atom.
	Ar-C-O	~150-160 ppm	Aromatic carbons directly attached to

Technique	Feature	Expected Chemical Shift / Frequency	Rationale
			the electron-donating methoxy groups.
	Ar-C	~110-130 ppm	Other aromatic carbons.
IR Spectroscopy	C=O Stretch	~1675 cm^{-1}	Strong absorption characteristic of a conjugated aryl ketone.[9]

| | C-O Stretch (Aryl Ether) | ~1250 cm^{-1} and ~1020 cm^{-1} | Two distinct bands are typical for aryl alkyl ethers.[9] |

Synthesis and Mechanism

The synthesis of **2-Bromo-2',5'-dimethoxyacetophenone** is a two-step process starting from the commercially available 1,4-dimethoxybenzene. The strategy involves an initial Friedel-Crafts acylation to form the ketone precursor, followed by a selective α -bromination.

Retrosynthetic Analysis

A logical retrosynthetic pathway disconnects the C-Br bond and subsequently the aryl-acyl C-C bond, tracing the target molecule back to simple precursors.

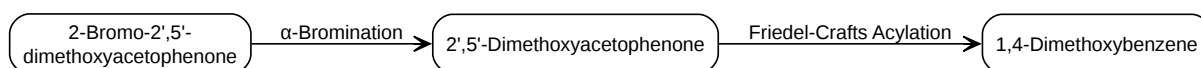

[Click to download full resolution via product page](#)

Caption: Retrosynthetic pathway for **2-Bromo-2',5'-dimethoxyacetophenone**.

Step 1: Synthesis of 2',5'-Dimethoxyacetophenone via Friedel-Crafts Acylation

The introduction of the acetyl group onto the 1,4-dimethoxybenzene ring is achieved via a classic Friedel-Crafts acylation.^{[10][11]} This reaction uses an acylating agent, such as acetyl chloride or acetic anhydride, and a strong Lewis acid catalyst like aluminum chloride (AlCl_3).

Causality of Experimental Design: The Lewis acid catalyst is crucial as it coordinates with the acylating agent to form a highly electrophilic acylium ion. This potent electrophile is then attacked by the electron-rich 1,4-dimethoxybenzene ring. The reaction is typically run at a low temperature (0 °C to room temperature) to control the reaction rate and minimize potential side reactions.^[10] Anhydrous conditions are essential as the Lewis acid reacts violently with water.

Detailed Experimental Protocol:

- **Setup:** A dry, three-necked round-bottom flask is equipped with a magnetic stirrer, a dropping funnel, and a nitrogen inlet connected to a gas bubbler.
- **Reagents:** The flask is charged with anhydrous aluminum chloride (1.1-1.3 molar equivalents) and a dry solvent such as dichloromethane (CH_2Cl_2).^[10] The suspension is cooled to 0 °C in an ice bath.
- **Addition:** A solution of 1,4-dimethoxybenzene (1.0 molar equivalent) and acetyl chloride (1.0-1.2 molar equivalents) in dichloromethane is added dropwise from the dropping funnel over 30-60 minutes, maintaining the internal temperature below 5 °C.^[10]
- **Reaction:** After the addition is complete, the reaction mixture is stirred at 0 °C for one hour and then allowed to warm to room temperature, stirring for an additional 1-3 hours.^[10] Reaction progress can be monitored by Thin Layer Chromatography (TLC).
- **Work-up:** The reaction is carefully quenched by slowly pouring the mixture over crushed ice containing concentrated hydrochloric acid. This hydrolyzes the aluminum complexes and moves the product into the organic layer.
- **Purification:** The organic layer is separated, washed with water and brine, dried over anhydrous sodium sulfate, and concentrated under reduced pressure. The resulting crude product can be purified by vacuum distillation or recrystallization to yield 2',5'-dimethoxyacetophenone.^{[10][12]}

Step 2: α -Bromination of 2',5'-Dimethoxyacetophenone

This key transformation introduces the bromine atom at the α -position of the ketone. The reaction is an acid-catalyzed α -substitution that proceeds through an enol intermediate.^{[2][13]}

Mechanism of Acid-Catalyzed Bromination: The reaction mechanism is a cornerstone of its synthetic utility and proceeds in three main steps:

- **Protonation:** The carbonyl oxygen is rapidly and reversibly protonated by the acid catalyst (e.g., HBr generated in situ or acetic acid solvent).
- **Enol Formation (Rate-Determining Step):** A base (e.g., water or the solvent) removes a proton from the α -carbon, leading to the formation of an enol intermediate. This tautomerization is the slowest step and thus dictates the overall reaction rate.^{[2][13][14]} The rate is dependent on the concentration of the ketone and the acid, but independent of the bromine concentration.^{[2][13]}
- **Electrophilic Attack:** The electron-rich double bond of the enol attacks molecular bromine (Br_2), forming a new C-Br bond and a protonated carbonyl. A final deprotonation step regenerates the acid catalyst and yields the final α -bromo ketone product.

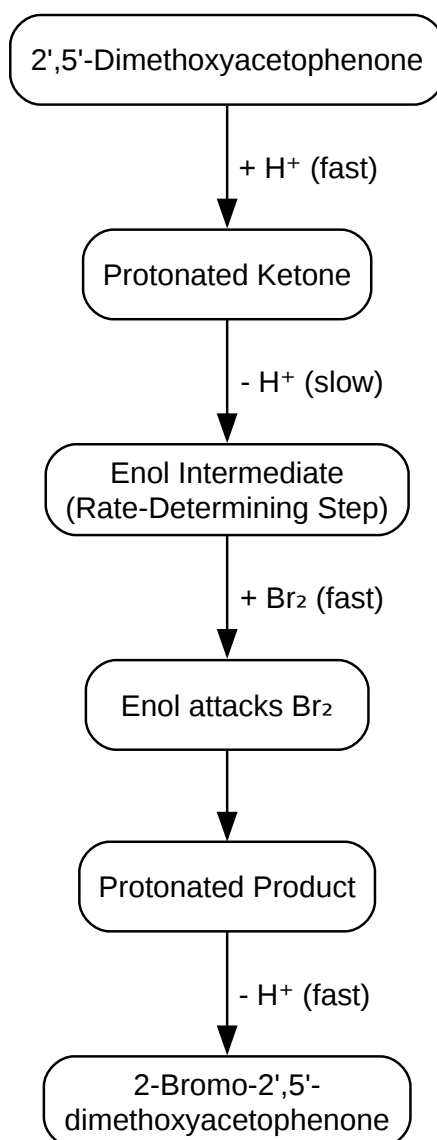

[Click to download full resolution via product page](#)

Caption: Mechanism of the acid-catalyzed α -bromination of acetophenone.

Detailed Experimental Protocol:

- Setup: A round-bottom flask is charged with 2',5'-dimethoxyacetophenone (1.0 molar equivalent) and a suitable solvent, such as acetic acid or chloroform.[6][13]
- Bromine Addition: The solution is stirred at room temperature. A solution of molecular bromine (1.0-1.1 molar equivalents) in the same solvent is added dropwise. Careful control

of the addition rate is critical to prevent a buildup of bromine and the formation of dibrominated byproducts.[2]

- **Alternative Brominating Agent:** Alternatively, a solid brominating agent like polymer-supported pyridinium bromide perbromide can be used for easier handling and work-up.[6] [15]
- **Reaction:** The reaction is stirred at room temperature until TLC analysis indicates the complete consumption of the starting material. The reaction is often accompanied by the disappearance of the bromine color and the evolution of HBr gas (which should be scrubbed).
- **Work-up:** The reaction mixture is diluted with water, and the product is extracted with an organic solvent like dichloromethane.
- **Purification:** The organic layer is washed with a dilute solution of sodium thiosulfate (to remove any excess bromine), followed by sodium bicarbonate solution and brine. After drying and solvent evaporation, the crude product, a pale yellow solid, is typically purified by recrystallization from a solvent like ethanol.

Applications in Research and Development

The utility of **2-Bromo-2',5'-dimethoxyacetophenone** stems from its identity as a bifunctional synthetic building block.

- **Pharmaceutical Synthesis:** It is a key starting material for the synthesis of the API Midodrine hydrochloride, a drug used to treat orthostatic hypotension.[16] Its structure serves as a precursor for a wide range of more complex molecules. Researchers leverage its reactivity to build scaffolds for compounds targeting neurological disorders and those with potential anti-inflammatory and anticancer properties.[1]
- **Materials Science:** The compound has found applications beyond pharmaceuticals. It is used in the development of organic photovoltaics, where it can be incorporated into materials designed to enhance light absorption and improve energy conversion efficiency.[1] Furthermore, its structural motifs are employed in the creation of novel fluorescent probes for use in biological imaging.[1]

Safety, Handling, and Storage

2-Bromo-2',5'-dimethoxyacetophenone is a hazardous chemical and must be handled with appropriate precautions.

Table 3: GHS Hazard Information

Pictogram(s)	Signal Word	Hazard Statements
--------------	-------------	-------------------

|
| Warning | H315: Causes skin irritation.[17][18] H319: Causes serious eye irritation.[17][18]
H335: May cause respiratory irritation.[17][18] H400: Very toxic to aquatic life.[17] |

- Handling: All manipulations should be performed in a well-ventilated fume hood. Personal protective equipment (PPE), including chemical-resistant gloves (e.g., nitrile), safety goggles, and a lab coat, is mandatory.[19] Avoid inhalation of dust and contact with skin and eyes.[19]
- Storage: The compound should be stored in a tightly sealed container in a cool, dry place. For long-term stability, storage at 0-8°C under an inert atmosphere is recommended.[1][3]
- Disposal: Waste must be disposed of as hazardous chemical waste in accordance with local and national regulations. Due to its high aquatic toxicity, it must not be released into the environment.[18]

Conclusion

2-Bromo-2',5'-dimethoxyacetophenone is a compound of significant synthetic value. Its well-defined molecular structure, characterized by a reactive α -bromo ketone, allows for predictable and versatile chemical transformations. The synthetic routes to this molecule are robust and based on fundamental organic reactions, making it an accessible intermediate for a broad range of applications. From its critical role in the synthesis of pharmaceuticals like Midodrine to its emerging use in advanced materials, **2-Bromo-2',5'-dimethoxyacetophenone** continues to be an important tool for chemists and researchers driving innovation in science and industry.

References

- PrepChem.com. (n.d.). Synthesis of 2,5-dimethoxyacetophenone. Retrieved from [[Link](#)]
- Quora. (2020). What is bromination acetophenone?. Retrieved from [[Link](#)]
- designer-drug.com. (n.d.). Synthesis of 2,5-Dimethoxyacetophenone. Retrieved from [[Link](#)]
- PubChem. (n.d.). **2-Bromo-2',5'-dimethoxyacetophenone**. Retrieved from [[Link](#)]
- Gao, et al. (2024). Application of α -bromination reaction on acetophenone derivatives in experimental teaching: a chemical innovation experiment engaging junior undergraduates. BMC Chemistry. Retrieved from [[Link](#)]
- Chemistry LibreTexts. (2024). 22.4: Alpha Halogenation of Aldehydes and Ketones. Retrieved from [[Link](#)]
- YouTube. (2014). Alpha Bromination of a Ketone 002. Retrieved from [[Link](#)]
- Organic Syntheses. (n.d.). 2,5-dihydroxyacetophenone. Retrieved from [[Link](#)]
- Vihita Drugs & Intermediates. (n.d.). 2-Bromo-2'5'-Dimethoxy Acetophenone. Retrieved from [[Link](#)]
- St. Paul's Cathedral Mission College. (n.d.). SPECTROSCOPIC ANALYSIS OF ORGANIC COMPOUNDS. Retrieved from [[Link](#)]
- OpenStax. (2023). 22.3 Alpha Halogenation of Aldehydes and Ketones. Retrieved from [[Link](#)]

Need Custom Synthesis?

BenchChem offers custom synthesis for rare earth carbides and specific isotopic labeling.

Email: info@benchchem.com or [Request Quote Online](#).

Sources

- 1. chemimpex.com [chemimpex.com]
- 2. pdf.benchchem.com [pdf.benchchem.com]

- [3. Page loading... \[guidechem.com\]](#)
- [4. scbt.com \[scbt.com\]](#)
- [5. chemscene.com \[chemscene.com\]](#)
- [6. 2-BROMO-2',5'-DIMETHOXYACETOPHENONE | 1204-21-3 \[chemicalbook.com\]](#)
- [7. 2-BROMO-2',5'-DIMETHOXYACETOPHENONE\(1204-21-3\) 13C NMR spectrum \[chemicalbook.com\]](#)
- [8. 2',5'-Dimethoxyacetophenone\(1201-38-3\) 1H NMR spectrum \[chemicalbook.com\]](#)
- [9. spcmc.ac.in \[spcmc.ac.in\]](#)
- [10. pdf.benchchem.com \[pdf.benchchem.com\]](#)
- [11. prepchem.com \[prepchem.com\]](#)
- [12. Article \[designer-drug.com\]](#)
- [13. chem.libretexts.org \[chem.libretexts.org\]](#)
- [14. chem.libretexts.org \[chem.libretexts.org\]](#)
- [15. researchgate.net \[researchgate.net\]](#)
- [16. 2-Bromo-2',5'-Dimethoxy Acetophenone | Vihita Drugs & Intermediates \[vihitadrugs.com\]](#)
- [17. 2-Bromo-2',5'-dimethoxyacetophenone | C10H11BrO3 | CID 70997 - PubChem \[pubchem.ncbi.nlm.nih.gov\]](#)
- [18. Page loading... \[guidechem.com\]](#)
- [19. fishersci.com \[fishersci.com\]](#)
- To cite this document: BenchChem. [2-Bromo-2',5'-dimethoxyacetophenone molecular structure]. BenchChem, [2026]. [Online PDF]. Available at: [\[https://www.benchchem.com/product/b1265504/docs#2-bromo-2-5-dimethoxyacetophenone-molecular-structure\]](https://www.benchchem.com/product/b1265504/docs#2-bromo-2-5-dimethoxyacetophenone-molecular-structure)

Disclaimer & Data Validity:

The information provided in this document is for Research Use Only (RUO) and is strictly not intended for diagnostic or therapeutic procedures. While BenchChem strives to provide accurate protocols, we make no warranties, express or implied, regarding the fitness of this product for every specific experimental setup.

Technical Support: The protocols provided are for reference purposes. Unsure if this reagent suits your experiment?

Need Industrial/Bulk Grade? [Request Custom Synthesis Quote](#)

BenchChem

Our mission is to be the trusted global source of essential and advanced chemicals, empowering scientists and researchers to drive progress in science and industry.

Contact

Address: 3281 E Guasti Rd
Ontario, CA 91761, United States
Phone: (601) 213-4426
Email: info@benchchem.com

[Contact our Ph.D. Support Team for a compatibility check](#)