

Mass Fragmentation Patterns: 3-((Ethylthio)methyl)heptane vs. Linear Thioethers

Author: BenchChem Technical Support Team. **Date:** April 2026

Compound of Interest

Compound Name: 3-((Ethylthio)methyl)heptane

CAS No.: 71607-39-1

Cat. No.: B12644965

[Get Quote](#)

Executive Summary

In Electron Ionization (EI) mass spectrometry, **3-((Ethylthio)methyl)heptane** (CAS 71607-39-1) exhibits a distinct fragmentation signature driven by its specific branching at the

-carbon relative to the sulfur atom. While linear thioethers (e.g., decyl ethyl sulfide) typically show a discernible molecular ion (

) and a base peak derived from

-cleavage, the branched structure of **3-((Ethylthio)methyl)heptane** significantly destabilizes the molecular ion, resulting in a lower relative abundance of

(m/z 174) and a dominant base peak at m/z 75.

This guide details the mechanistic pathways—specifically the Sulfur-Assisted

-Cleavage—that differentiate this compound from its linear analogs.

Structural Analysis & Theoretical Basis

To understand the fragmentation, we must first dissect the connectivity which dictates bond lability.

- Compound: **3-((Ethylthio)methyl)heptane**
- Molecular Formula:
- Molecular Weight: 174.35 Da
- Structural Key: The molecule consists of a heptane chain substituted at position 3 with an (ethylthio)methyl group ().

Critical Structural Feature: The sulfur atom is flanked by an ethyl group on one side and a methylene bridge attached to a secondary carbon (C3 of heptane) on the other. This branching creates a stable leaving group (the 3-heptyl radical) upon

-cleavage.

Primary Fragmentation Mechanisms

The fragmentation of thioethers is governed by the high polarizability of sulfur and its ability to stabilize a positive charge.

Mechanism A: -Cleavage (Dominant Pathway)

The most abundant ion arises from the cleavage of the C-C bond adjacent to the C-S bond.

- Ionization: Removal of a non-bonding electron from sulfur yields the radical cation .
- Rearrangement: The radical on sulfur induces formation of a double bond with the adjacent methylene bridge ().
- Cleavage: To satisfy valency, the bond between the methylene bridge and the heptane backbone breaks.

- Result: Formation of the stable ethylthio-methylene cation (m/z 75) and a neutral 3-heptyl radical.

Why this dominates: The neutral 3-heptyl radical is a secondary radical, which is energetically more stable than the primary alkyl radicals lost during the fragmentation of linear thioethers. This thermodynamic stability accelerates the reaction, making m/z 75 the absolute base peak.

Mechanism B: C-S Bond Scission

A secondary pathway involves the heterolytic cleavage of the C-S bond, yielding the ethylsulfanylium ion (m/z 61). This is less favorable than

α -cleavage but serves as a diagnostic marker for the ethyl-sulfur moiety.

Mechanism C: McLafferty-Like Rearrangement

While less prominent due to the dominance of

α -cleavage, the heptyl chain allows for hydrogen migration to the sulfur atom, potentially yielding ions at m/z 62 (

) or m/z 47 (

) via secondary decomposition.

Visualization of Fragmentation Pathways

The following diagram illustrates the competitive pathways, highlighting the dominance of the

α -cleavage route.

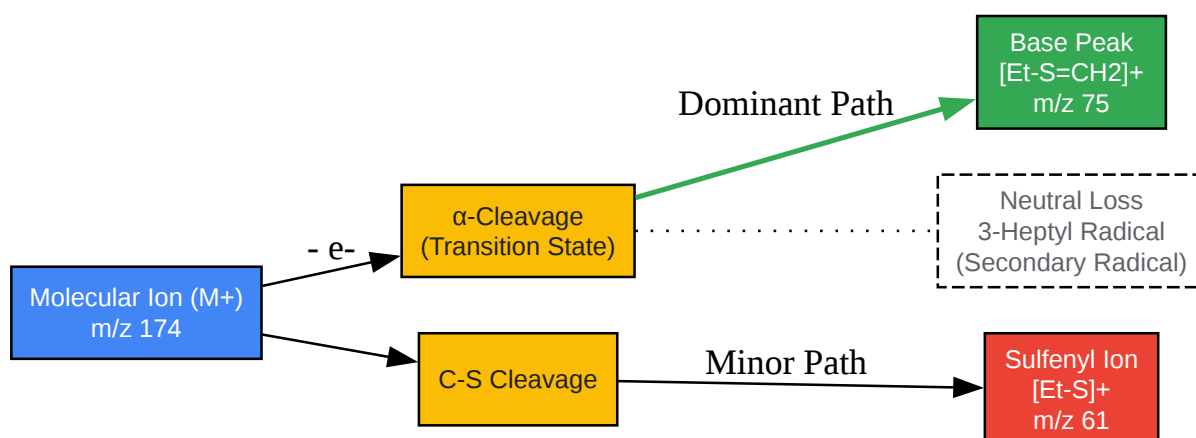

[Click to download full resolution via product page](#)

Caption: Mechanistic flow showing the preferential formation of the m/z 75 base peak driven by the stability of the neutral secondary radical loss.

Comparative Analysis: Branched vs. Linear Thioethers

The following table contrasts **3-((Ethylthio)methyl)heptane** with n-Octyl Ethyl Sulfide, a linear isomer of identical molecular weight (

).

Feature	3-((Ethylthio)methyl)heptane (Branched)	n-Octyl Ethyl Sulfide (Linear)	Mechanistic Driver
Molecular Ion (m/z 174)	Weak (<5%)	Moderate (10-20%)	Branching destabilizes by offering lower-energy fragmentation channels.
Base Peak	m/z 75 ()	m/z 75 ()	Both form the same stable sulfonium ion, but the branched precursor reacts faster.
Key Neutral Loss	3-Heptyl Radical (Secondary)	n-Octyl Radical (Primary)	Secondary radicals are more stable than primary, driving the reaction equilibrium toward products.
Diagnostic Alkyl Ions	m/z 43, 57, 71 (Branched pattern)	m/z 43, 57, 71, 85... (Linear series)	The heptyl chain fragmentation overlays the sulfide spectrum.
m/z 61 ()	Present	Present	Direct C-S cleavage; common to both.

Experimental Protocol for Validation

To replicate these findings or validate an unknown sample, use the following standardized GC-MS protocol. This setup ensures sufficient ionization energy to observe the diagnostic fragments while maintaining resolution.

Instrument Configuration

- System: Gas Chromatograph coupled to Single Quadrupole Mass Spectrometer.
- Ionization Mode: Electron Impact (EI).[1][2]
- Electron Energy: 70 eV (Standard for library matching).
- Source Temperature: 230°C.
- Transfer Line: 280°C.

Chromatographic Method[3]

- Column: Non-polar capillary column (e.g., DB-5ms or equivalent), 30m x 0.25mm ID x 0.25µm film.
- Carrier Gas: Helium at 1.0 mL/min (constant flow).
- Injection: Splitless (1 µL) at 250°C.
- Oven Program:
 - Initial: 60°C (hold 1 min).
 - Ramp: 10°C/min to 280°C.
 - Final: Hold 5 min.

Data Interpretation Step-by-Step

- Check m/z 174: Look for a small molecular ion peak. If absent, check for M-29 or M-15.
- Verify Base Peak: Confirm m/z 75 is the dominant peak (100% relative abundance).[1]
- Search for m/z 61: Presence confirms the ethyl-sulfur group.
- Analyze Alkyl Region: Look for m/z 43 () and m/z 57 () arising from the heptyl tail.

- Exclusion: If m/z 47 () is the base peak, the compound is likely a methyl sulfide, not an ethyl sulfide.

References

- NIST Mass Spectrometry Data Center. Mass Spectrum of 3-Ethyl-3-methylheptane (Hydrocarbon Analog) & General Thioether Patterns. NIST Standard Reference Database 1A v17. [\[Link\]](#)
- PubChem. Compound Summary: **3-((Ethylthio)methyl)heptane** (CAS 71607-39-1). National Library of Medicine. [\[Link\]](#)
- McLafferty, F. W., & Tureček, F. (1993). Interpretation of Mass Spectra (4th ed.). University Science Books. (Standard reference for α -cleavage mechanisms in sulfides).
- Gross, J. H. (2017). Mass Spectrometry: A Textbook. Springer International Publishing. (Source for sulfonium ion stability rules).

Need Custom Synthesis?

BenchChem offers custom synthesis for rare earth carbides and specific isotopic labeling.

Email: info@benchchem.com or [Request Quote Online](#).

Sources

- 1. pubs.aip.org [pubs.aip.org]
- 2. [scribd.com](https://www.scribd.com) [[scribd.com](https://www.scribd.com)]
- To cite this document: BenchChem. [Mass Fragmentation Patterns: 3-((Ethylthio)methyl)heptane vs. Linear Thioethers]. BenchChem, [2026]. [\[Online PDF\]](#). Available at: [<https://www.benchchem.com/product/b12644965/docs#mass-fragmentation-patterns-3-ethylthio-methyl-heptane-vs-linear-thioethers>]

Disclaimer & Data Validity:

The information provided in this document is for Research Use Only (RUO) and is strictly not intended for diagnostic or therapeutic procedures. While BenchChem strives to provide

accurate protocols, we make no warranties, express or implied, regarding the fitness of this product for every specific experimental setup.

Technical Support: The protocols provided are for reference purposes. Unsure if this reagent suits your experiment?

Need Industrial/Bulk Grade? [Request Custom Synthesis Quote](#)

BenchChem

Our mission is to be the trusted global source of essential and advanced chemicals, empowering scientists and researchers to drive progress in science and industry.

Contact

Address: 3281 E Guasti Rd
Ontario, CA 91761, United States
Phone: (601) 213-4426
Email: info@benchchem.com

[Contact our Ph.D. Support Team for a compatibility check](#)