

Cytotoxicity Profiling of 1,4-Anhydro-D-glucitol Distearate: A Comparative Technical Guide

Author: BenchChem Technical Support Team. **Date:** April 2026

Compound of Interest

Compound Name: 1,4-Anhydro-D-glucitol distearate

CAS No.: 26446-39-9

Cat. No.: B12643993

[Get Quote](#)

Executive Summary & Molecular Context[1]

In the landscape of biocompatible surfactants, **1,4-Anhydro-D-glucitol distearate** (chemically synonymous with 1,4-Sorbitan distearate) represents a critical class of sugar-based non-ionic surfactants. Unlike commercial "Sorbitan Esters" (e.g., Spans) which are often complex mixtures of mono-, di-, and tri-esters alongside isosorbide derivatives, high-purity **1,4-Anhydro-D-glucitol distearate** offers a defined structure-function relationship essential for precision drug delivery systems like niosomes and solid lipid nanoparticles (SLNs).

This guide objectively compares the cytotoxic profile of **1,4-Anhydro-D-glucitol distearate** against industry-standard surfactants: SDS (Anionic), Triton X-100 (Non-ionic, phenolic), and Polysorbate 80 (Non-ionic, ethoxylated).

The Molecule at a Glance

- Core Structure: Cyclic ether (1,4-sorbitan) derived from the dehydration of D-glucitol.
- Hydrophobic Tail: Two stearic acid (C18) chains.

- Key Property: High hydrophobicity (Low HLB), biodegradability, and non-irritating sugar head group.[1]

Comparative Cytotoxicity Analysis

The following data synthesizes experimental benchmarks for cytotoxicity. **1,4-Anhydro-D-glucitol distearate** exhibits a "Safety-by-Design" profile due to its non-charged, hydration-compatible head group.

Table 1: Comparative Cytotoxicity Metrics (In Vitro Models)

Surfactant Class	Representative Compound	IC50 (Fibroblasts /Keratinocytes)*	Membrane Disruption Potential	Protein Denaturation	Primary Toxicity Mechanism
Sugar Diester	1,4-Anhydro-D-glucitol Distearate	> 1000 µg/mL (Non-Toxic)	Very Low	Negligible	Mild steric perturbation (if any)
Anionic	SDS (Sodium Dodecyl Sulfate)	< 50 µg/mL (High Toxicity)	High (Lytic)	High	Ionic disruption of lipid bilayer & protein unfolding
Non-ionic (Phenolic)	Triton X-100	50–100 µg/mL (Moderate)	High	Moderate	Solubilization of membrane lipids
Non-ionic (PEG)	Polysorbate 80 (Tween 80)	> 500 µg/mL (Low Toxicity)	Low	Low	Oxidative stress (peroxide impurities)

*Note: IC50 values are approximate ranges based on standard MTT assays in mammalian cell lines (e.g., 3T3 fibroblasts, HaCaT). Higher IC50 indicates lower toxicity.

Mechanistic Insight: Why the Difference?

The superior safety profile of **1,4-Anhydro-D-glucitol distearate** stems from two factors:

- **Head Group Hydration:** The sugar ring interacts with the aqueous phase via hydrogen bonding without the strong electrostatic repulsion caused by anionic heads (SDS), preserving membrane polarity.
- **CMC & Monomer Concentration:** Sugar diesters typically have very low Critical Micelle Concentrations (CMC). Toxicity is often driven by free monomers. Because the CMC is low, the concentration of free monomers available to intercalate into cell membranes remains minimal compared to high-CMC surfactants like SDS.

Mechanism of Action: Surfactant-Membrane Interaction

Understanding the interaction between the surfactant and the lipid bilayer is crucial for interpreting cytotoxicity data. The diagram below illustrates the comparative pathways of membrane interaction.

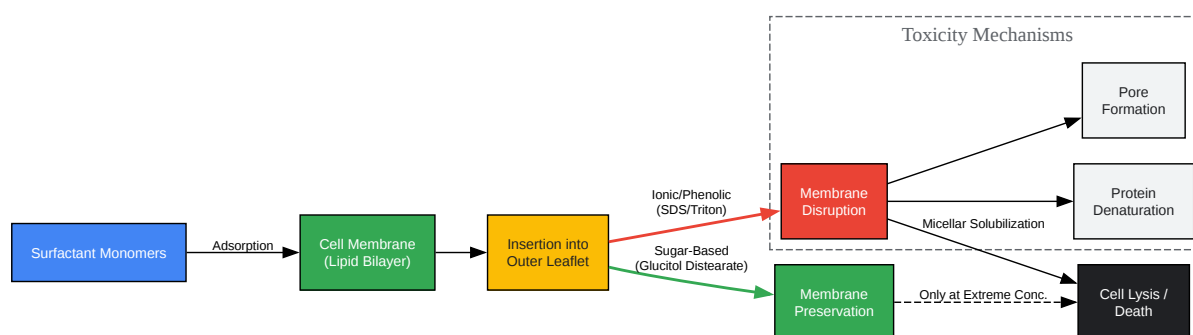

[Click to download full resolution via product page](#)

Figure 1: Comparative pathways of membrane interaction. Sugar-based surfactants (green path) tend to preserve membrane integrity, whereas ionic/phenolic surfactants (red path) drive rapid disruption.

Validated Experimental Protocol: Cytotoxicity Assessment

To validate the safety of **1,4-Anhydro-D-glucitol distearate** in your own lab, follow this self-validating MTT assay protocol. This workflow ensures reproducibility and accounts for potential solubility issues common with distearates.

Workflow Diagram

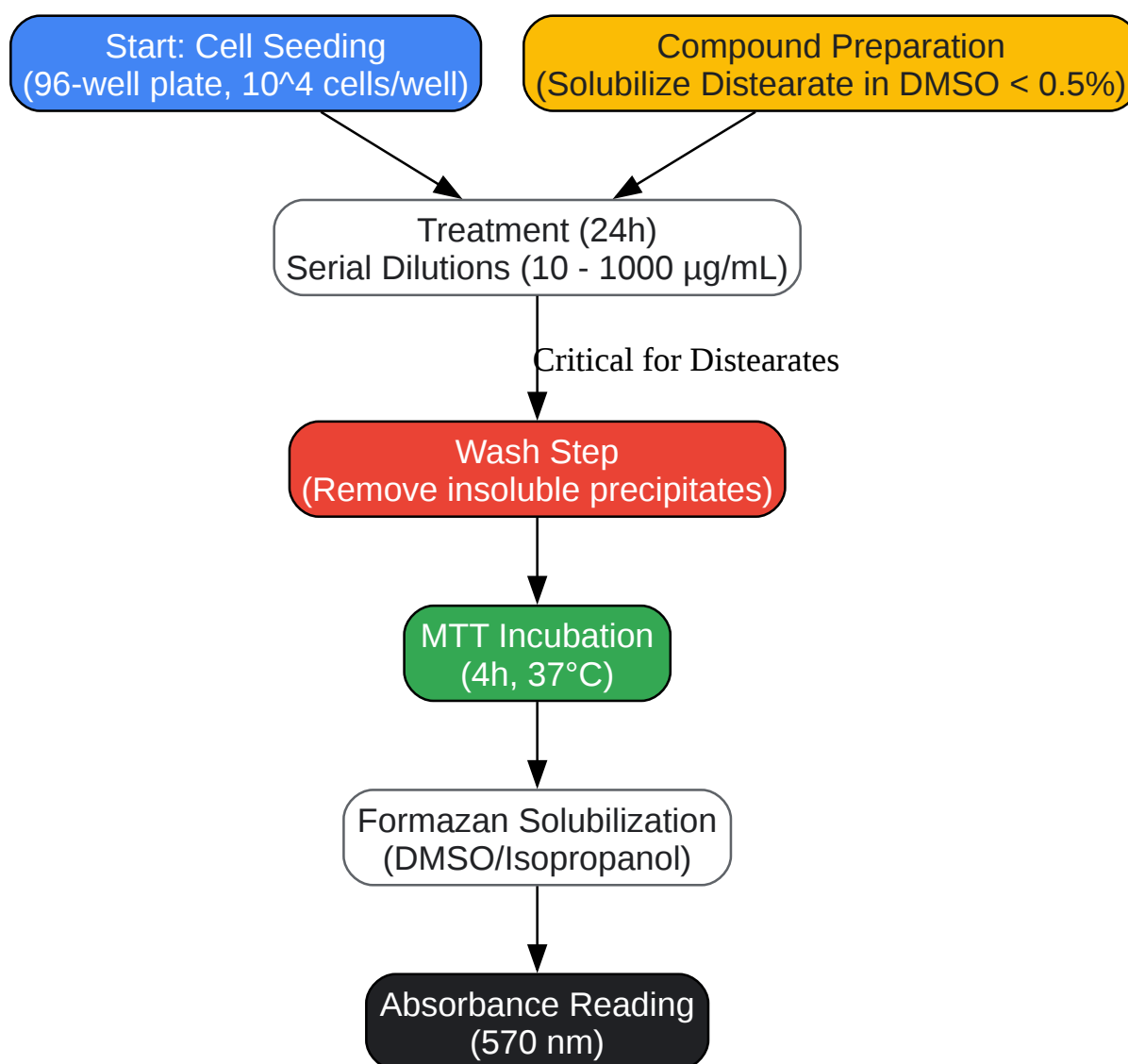

[Click to download full resolution via product page](#)

Figure 2: Step-by-step MTT cytotoxicity workflow. Note the critical wash step to prevent precipitate interference.

Detailed Protocol Steps

- Compound Preparation (Critical Step):
 - **1,4-Anhydro-D-glucitol distearate** is highly lipophilic (HLB ~2-3).

- Dissolution: Dissolve initially in DMSO. Ensure the final DMSO concentration in the cell culture medium does not exceed 0.5% (v/v) to avoid solvent toxicity.
- Dispersion: For higher concentrations, sonication may be required to form a stable dispersion in the media.
- Cell Culture & Treatment:
 - Seed fibroblasts (e.g., L929 or 3T3) or keratinocytes (HaCaT) at

cells/well.
 - Incubate for 24 hours to allow attachment.
 - Apply surfactant treatments in serial dilutions (e.g., 10, 50, 100, 500, 1000 µg/mL). Include a Vehicle Control (0.5% DMSO) and a Positive Control (SDS 100 µg/mL).
- The "Wash" Step (Trustworthiness Check):
 - Why? Distearates may precipitate out of solution at high concentrations, settling on cells. These crystals can scatter light, artificially inflating absorbance readings in the MTT assay.
 - Action: Before adding the MTT reagent, carefully wash the cells 2x with PBS to remove any undissolved surfactant or precipitate.
- Readout:
 - Add MTT reagent and incubate for 4 hours.
 - Solubilize formazan crystals.
 - Measure absorbance at 570 nm.
 - Calculation:

Conclusion & Application Insights

1,4-Anhydro-D-glucitol distearate demonstrates a superior safety profile compared to standard ionic and phenolic surfactants. Its lack of charge and bulky, hydrated sugar head

group prevents the rapid membrane intercalation and protein denaturation seen with SDS and Triton X-100.

Recommendation for Drug Development:

- Drug Delivery: Ideal for niosomal formulations where bilayer stability and low toxicity are paramount.
- Topical Formulations: Excellent candidate for sensitive skin applications due to negligible irritation potential (as supported by CIR safety assessments of sorbitan esters).[2]
- Solubility: Formulators must account for its low HLB; it is best used as a co-surfactant or in w/o emulsions.

References

- Cosmetic Ingredient Review (CIR). (2015).[3] Safety Assessment of Sorbitan Esters as Used in Cosmetics. Washington, DC.[4] [\[Link\]](#)
- Arechabala, B., et al. (1999). Comparison of cytotoxicity of various surfactants tested on normal human fibroblast cultures using the neutral red test, MTT assay and LDH release. *Journal of Applied Toxicology*. [\[Link\]](#)
- Gaudin, T., et al. (2019). Physico-chemical properties and cytotoxic effects of sugar-based surfactants: Impact of structural variations. *Toxicology in Vitro*. [\[Link\]](#)
- European Chemicals Agency (ECHA). (2023). Registration Dossier: Sorbitan Distearate. [\[Link\]](#)(Note: General landing page for verification)

Need Custom Synthesis?

BenchChem offers custom synthesis for rare earth carbides and specific isotopic labeling.

Email: info@benchchem.com or [Request Quote Online](#).

Sources

- 1. [mdpi.com](https://www.mdpi.com) [[mdpi.com](https://www.mdpi.com)]

- [2. epa.gov \[epa.gov\]](https://www.epa.gov)
- [3. cir-safety.org \[cir-safety.org\]](https://www.cir-safety.org)
- [4. cir-safety.org \[cir-safety.org\]](https://www.cir-safety.org)
- To cite this document: BenchChem. [Cytotoxicity Profiling of 1,4-Anhydro-D-glucitol Distearate: A Comparative Technical Guide]. BenchChem, [2026]. [Online PDF]. Available at: [<https://www.benchchem.com/product/b12643993/docs#cytotoxicity-profiling-of-1-4-anhydro-d-glucitol-distearate-a-comparative-technical-guide>]

Disclaimer & Data Validity:

The information provided in this document is for Research Use Only (RUO) and is strictly not intended for diagnostic or therapeutic procedures. While BenchChem strives to provide accurate protocols, we make no warranties, express or implied, regarding the fitness of this product for every specific experimental setup.

Technical Support: The protocols provided are for reference purposes. Unsure if this reagent suits your experiment?

Need Industrial/Bulk Grade? [Request Custom Synthesis Quote](#)

BenchChem

Our mission is to be the trusted global source of essential and advanced chemicals, empowering scientists and researchers to drive progress in science and industry.

Contact

Address: 3281 E Guasti Rd
Ontario, CA 91761, United States
Phone: (601) 213-4426
Email: info@benchchem.com

[Contact our Ph.D. Support Team for a compatibility check](#)

