

Technical Support Center: Optimizing Reaction Conditions for Diisooctylphenol Synthesis

Author: BenchChem Technical Support Team. **Date:** April 2026

Compound of Interest

Compound Name: *Diisooctylphenol*

CAS No.: 85958-96-9

Cat. No.: B12642803

[Get Quote](#)

Welcome to the technical support center for the synthesis of **diisooctylphenol**. This guide is designed for researchers, scientists, and professionals in drug development and materials science. Here, we provide in-depth troubleshooting advice and frequently asked questions to help you navigate the complexities of this alkylation reaction and achieve optimal results in your experiments.

Troubleshooting Guide: Common Issues and Solutions

This section addresses specific experimental challenges in a question-and-answer format, providing potential causes and actionable solutions based on established chemical principles.

Question 1: Why is my **diisooctylphenol** yield consistently low?

Potential Causes & Solutions:

- **Suboptimal Catalyst Choice or Activity:** The selection of an appropriate acid catalyst is critical for efficient alkylation.

- Insight: Strong Brønsted acids like sulfuric acid or solid acid catalysts such as Amberlyst-15 are commonly employed.[1] The choice of catalyst can influence the reaction rate and selectivity.
- Solution:
 - Catalyst Screening: If using a solid acid catalyst, screen different types (e.g., zeolites, ion-exchange resins) to find the one with the best performance for your specific isooctene isomer.[2]
 - Catalyst Loading: Ensure the catalyst loading is optimized. Typically, this ranges from 5-15% by weight of phenol. Start with a lower concentration and incrementally increase it while monitoring the reaction progress.
 - Catalyst Deactivation: If reusing a solid catalyst, it may have become deactivated. Regenerate the catalyst according to the manufacturer's instructions or use a fresh batch.
- Incorrect Molar Ratio of Reactants: The stoichiometry of phenol to isooctene plays a significant role in determining the product distribution.
 - Insight: To favor the formation of the dialkylated product, a molar excess of the olefin is generally required.[3] However, too large an excess can lead to unwanted side reactions like olefin oligomerization.[4]
 - Solution:
 - Ratio Optimization: Systematically vary the phenol to isooctene molar ratio. Start with a 1:2.2 ratio and adjust based on your results.
 - Controlled Addition: Instead of adding all the isooctene at once, consider a gradual addition to maintain a more constant concentration throughout the reaction, which can suppress side reactions.
- Inadequate Reaction Temperature: The reaction temperature affects both the rate of reaction and the prevalence of side reactions.

- Insight: Alkylation of phenols is typically an exothermic process.[5] Insufficient temperature will lead to a slow reaction, while excessive heat can promote side reactions and catalyst degradation.
- Solution:
 - Temperature Control: Maintain a stable reaction temperature, typically in the range of 80-140°C for this type of alkylation.[6]
 - Exotherm Management: For larger-scale reactions, ensure efficient heat dissipation to prevent runaway reactions.
- Presence of Water: Water can deactivate many acid catalysts and interfere with the reaction.
 - Insight: Lewis acid catalysts, in particular, are sensitive to moisture.
 - Solution:
 - Anhydrous Conditions: Use anhydrous grade phenol and isooctene. If necessary, dry the reactants before use.
 - Inert Atmosphere: Conduct the reaction under an inert atmosphere (e.g., nitrogen or argon) to prevent the ingress of atmospheric moisture.

Question 2: My product mixture contains a high proportion of mono-isooctylphenol and unreacted phenol. How can I increase the conversion to the di-substituted product?

Potential Causes & Solutions:

- Insufficient Isooctene: A molar deficit of the alkylating agent will naturally lead to incomplete alkylation.
 - Insight: The second alkylation step is generally slower than the first due to steric hindrance.
 - Solution:

- Increase Isooctene Ratio: As mentioned previously, increase the molar ratio of isooctene to phenol. A ratio of 1:2.5 or even slightly higher might be necessary.
- Reaction Time: Extend the reaction time to allow for the slower second alkylation to proceed to completion. Monitor the reaction progress using techniques like GC or TLC.
- Reaction Equilibrium: The alkylation of phenols can be a reversible process.[7]
 - Insight: At higher temperatures, dealkylation can occur, leading to an equilibrium mixture of starting materials and products.
 - Solution:
 - Optimize Temperature: Find the optimal temperature that provides a good reaction rate without significantly favoring the reverse reaction.
 - Product Removal (if feasible): In some systems, continuous removal of the product can drive the reaction to completion, although this is often not practical for batch syntheses of this type.

Question 3: I am observing the formation of significant amounts of byproducts, such as phenyl isooctyl ether and isooctene oligomers. How can I improve the selectivity for C-alkylation?

Potential Causes & Solutions:

- O-Alkylation vs. C-Alkylation: The formation of phenyl isooctyl ether is a result of O-alkylation, which competes with the desired C-alkylation.
 - Insight: O-alkylation is often favored under kinetic control (lower temperatures), while C-alkylation is the thermodynamically more stable product and is favored at higher temperatures.[1] The alkyl group can also rearrange from the oxygen to the ring.[1]
 - Solution:
 - Increase Reaction Temperature: Carefully increasing the reaction temperature can promote the rearrangement of the O-alkylated intermediate to the C-alkylated product.

- Catalyst Choice: Certain catalysts have a higher selectivity for C-alkylation. For instance, some solid acid catalysts with specific pore structures can sterically hinder the formation of the O-alkylated product.[2]
- Olefin Oligomerization: Isooctene can polymerize in the presence of a strong acid catalyst.[4]
 - Insight: This side reaction consumes the alkylating agent and can lead to complex and difficult-to-remove impurities.
 - Solution:
 - Moderate Temperature: Avoid excessively high temperatures, which can accelerate polymerization.
 - Controlled Addition of Olefin: A slow, continuous addition of isooctene can keep its instantaneous concentration low, thereby minimizing oligomerization.
 - Phenol to Olefin Ratio: A higher ratio of phenol to olefin can also help to suppress olefin oligomerization.[4]

Question 4: My final product is difficult to purify. What strategies can I use?

Potential Causes & Solutions:

- Similar Physical Properties of Products and Byproducts: The boiling points and polarities of mono-, di-, and poly-alkylated phenols, as well as oligomeric byproducts, can be very similar.
 - Insight: This makes purification by standard distillation or chromatography challenging.
 - Solution:
 - Fractional Distillation under Vacuum: For liquid products, careful fractional distillation under reduced pressure is the most common method. Use a column with a high number of theoretical plates for better separation.
 - Crystallization: If the desired **diisooctylphenol** isomer is a solid, crystallization can be a highly effective purification method.[8] Experiment with different solvents and solvent mixtures to find conditions that selectively crystallize the desired product.

- Chromatography: While challenging, column chromatography using a suitable stationary phase (e.g., silica gel) and an optimized solvent system (e.g., hexane/ethyl acetate gradients) can be used for purification, especially at a smaller scale.[9]

Experimental Protocols & Data

General Protocol for Diisooctylphenol Synthesis

- Reaction Setup: In a three-necked round-bottom flask equipped with a mechanical stirrer, a reflux condenser, a dropping funnel, and a temperature probe, add phenol and the acid catalyst.
- Inert Atmosphere: Purge the system with an inert gas like nitrogen.
- Heating: Heat the mixture to the desired reaction temperature (e.g., 100°C) with stirring.
- Reactant Addition: Add isooctene dropwise from the dropping funnel over a period of 1-2 hours.
- Reaction Monitoring: Monitor the progress of the reaction by taking small aliquots and analyzing them by GC or TLC.
- Work-up: Once the reaction is complete, cool the mixture to room temperature. If a solid catalyst was used, it can be removed by filtration. For liquid acid catalysts, neutralize with a base (e.g., a dilute solution of sodium carbonate or sodium hydroxide). Wash the organic layer with water and brine.
- Purification: Dry the organic layer over an anhydrous salt (e.g., sodium sulfate) and remove the solvent under reduced pressure. Purify the crude product by vacuum distillation or crystallization.

Table 1: Typical Reaction Parameters for Diisooctylphenol Synthesis

Parameter	Recommended Range	Rationale
Phenol:Isooctene Molar Ratio	1 : 2.2 - 1 : 2.8	An excess of olefin is needed to drive the reaction towards the di-substituted product.[3]
Catalyst Loading (Solid Acid)	5 - 15 wt% of phenol	Balances reaction rate with cost and potential for side reactions.
Temperature	80 - 140 °C	Optimizes the rate of C-alkylation while minimizing side reactions like oligomerization and dealkylation.[6]
Reaction Time	4 - 10 hours	Sufficient time for the slower second alkylation to occur. Monitor for completion.
Stirring Speed	> 300 RPM	Ensures good mixing, especially with heterogeneous catalysts.

Visualizing the Process

Reaction Mechanism

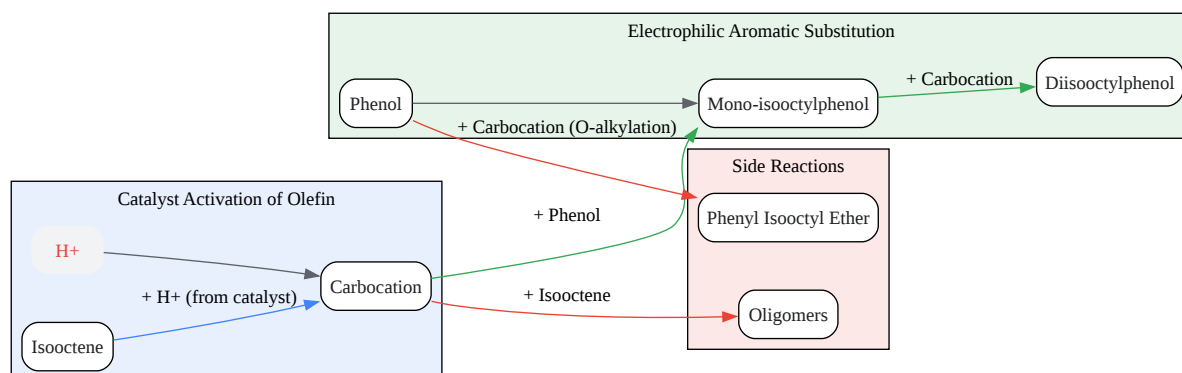

[Click to download full resolution via product page](#)

Caption: Friedel-Crafts alkylation of phenol with isooctene.

Troubleshooting Workflow

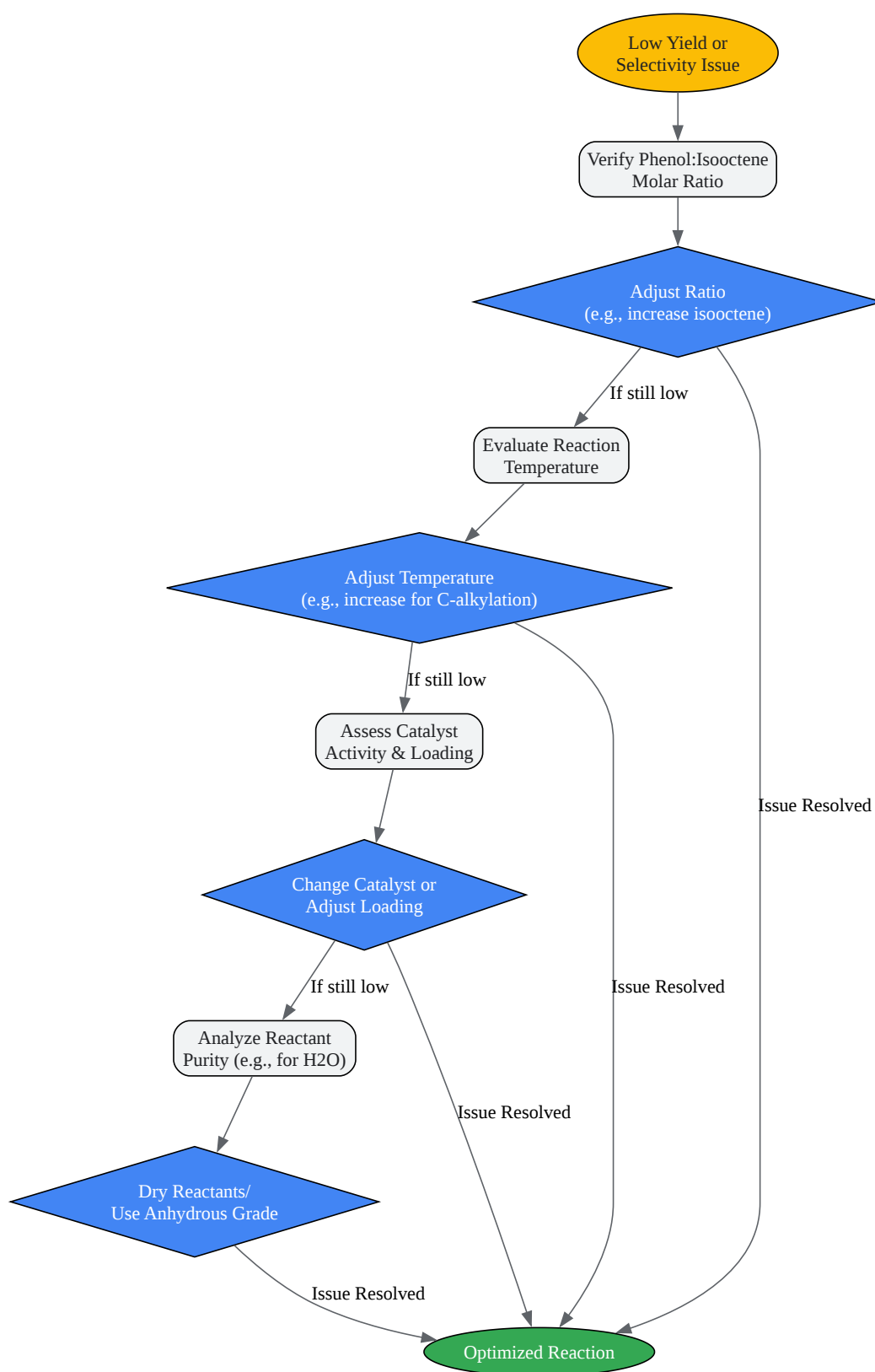

[Click to download full resolution via product page](#)

Caption: Systematic approach to troubleshooting **diisooctylphenol** synthesis.

Frequently Asked Questions (FAQs)

Q1: What is the role of the acid catalyst in the synthesis of **diisooctylphenol**?

The acid catalyst, whether it's a Brønsted acid or a Lewis acid, plays a pivotal role in generating the electrophile required for the Friedel-Crafts alkylation reaction. It protonates the isooctene, forming a secondary or tertiary carbocation. This highly reactive carbocation is then attacked by the electron-rich phenol ring, leading to the formation of a new carbon-carbon bond.

Q2: Should I be concerned about the different isomers of isooctene?

Yes, the isomeric composition of your isooctene starting material can influence the structure of the final product and the reaction conditions required. Different isomers may have different reactivities and may lead to the formation of different carbocation intermediates, potentially resulting in a mixture of **diisooctylphenol** isomers. It is important to be consistent with the source and composition of your isooctene for reproducible results.

Q3: How can I monitor the progress of my reaction effectively?

Gas Chromatography (GC) is an excellent technique for monitoring the disappearance of starting materials (phenol and isooctene) and the appearance of the mono- and di-alkylated products. Thin-Layer Chromatography (TLC) can also be used for a more qualitative and rapid assessment of the reaction's progress.

Q4: Are there any safety precautions I should take when running this reaction?

Yes. Phenol is corrosive and toxic; always handle it in a well-ventilated fume hood and wear appropriate personal protective equipment (PPE), including gloves and safety glasses. Strong acid catalysts are also highly corrosive. The reaction can be exothermic, so ensure proper temperature control to prevent runaways.

Q5: Can I use a solvent for this reaction?

While the reaction can often be run neat (without a solvent), using a non-polar, high-boiling solvent like toluene or xylene can sometimes be advantageous. A solvent can help with

temperature control and can be beneficial when working with solid catalysts to ensure efficient mixing. However, the use of a solvent will require an additional removal step during work-up.

References

- Journal of Synthetic Chemistry. (2024).
- Google Patents. (2017).
- Google Patents. (1992). Process for the purification of 2,6-diisopropyl phenol. (EP0511947B1).
- Google Patents. (1995).
- Benchchem.
- Benchchem. Troubleshooting guide for the synthesis of 6-Methyl-2-phenyl-1,3-benzothiazole.
- ResearchGate. (n.d.).
- Google Patents. (1951). Alkylation of phenolic compounds with olefins. (US2567848A).
- TriLink BioTechnologies. Troubleshooting the Synthesis of Modified Oligonucleotides.
- MDPI. (2023).
- MDPI. (2025). Coal Tar Naphtha Refining: Phenol Alkylation with 1-Hexene and the Impact of Pyridine.
- Reddit. (2023). Peptide synthesis troubleshooting.
- PubMed. (2006).
- PubMed. (2014). Synthesis of terephthalic acid via Diels-Alder reactions with ethylene and oxidized variants of 5-hydroxymethylfurfural.
- Organic Chemistry Portal.
- PMC. Troubleshooting for F-18 Fluorocholine Synthesis: An Institutional Experience.
- Alfa Chemistry.
- Benchchem. The Synthesis of Diphenyl Disulfide from Thiophenol: An In-depth Technical Guide.
- Thermo Fisher Scientific.
- The Essential Chemical Industry.
- Technologia i Jakość Wytrobów. (2021).
- Benchchem. Technical Support Center: Troubleshooting Common Issues in FDG Radiolabeling.
- ResearchGate. (2025).
- Ethyl Acetate Plant. (2024).
- Google Patents. (2011).
- Master Organic Chemistry. (2016). Natural Product Isolation (2)
- Google Patents. (2022). Catalytic method for synthesizing bisphenol F. (CN114835559B).

- MilliporeSigma.

Need Custom Synthesis?

BenchChem offers custom synthesis for rare earth carbides and specific isotopic labeling.

Email: info@benchchem.com or [Request Quote Online](#).

Sources

- 1. Alkylation of phenol: a mechanistic view - PubMed [pubmed.ncbi.nlm.nih.gov]
- 2. [researchgate.net](https://www.researchgate.net) [[researchgate.net](https://www.researchgate.net)]
- 3. US2567848A - Alkylation of phenolic compounds with olefins - Google Patents [patents.google.com]
- 4. [mdpi.com](https://www.mdpi.com) [[mdpi.com](https://www.mdpi.com)]
- 5. Cracking and related refinery processes [[essentialchemicalindustry.org](https://www.essentialchemicalindustry.org)]
- 6. WO2017042181A1 - Process for the alkylation of phenols - Google Patents [patents.google.com]
- 7. [researchgate.net](https://www.researchgate.net) [[researchgate.net](https://www.researchgate.net)]
- 8. EP0511947B1 - Process for the purification of 2,6-diisopropyl phenol - Google Patents [patents.google.com]
- 9. [masterorganicchemistry.com](https://www.masterorganicchemistry.com) [[masterorganicchemistry.com](https://www.masterorganicchemistry.com)]
- To cite this document: BenchChem. [Technical Support Center: Optimizing Reaction Conditions for Diisooctylphenol Synthesis]. BenchChem, [2026]. [Online PDF]. Available at: [<https://www.benchchem.com/product/b12642803/docs#technical-support-center-optimizing-reaction-conditions-for-diisooctylphenol-synthesis>]

Disclaimer & Data Validity:

The information provided in this document is for Research Use Only (RUO) and is strictly not intended for diagnostic or therapeutic procedures. While BenchChem strives to provide accurate protocols, we make no warranties, express or implied, regarding the fitness of this product for every specific experimental setup.

Technical Support: The protocols provided are for reference purposes. Unsure if this reagent suits your experiment?

Need Industrial/Bulk Grade? [Request Custom Synthesis Quote](#)

BenchChem

Our mission is to be the trusted global source of essential and advanced chemicals, empowering scientists and researchers to drive progress in science and industry.

Contact

Address: 3281 E Guasti Rd
Ontario, CA 91761, United States
Phone: (601) 213-4426
Email: info@benchchem.com

[Contact our Ph.D. Support Team for a compatibility check](#)