

# AZD5597 vs. Abemaciclib: A Comparative Guide on Kinase Selectivity Profiles

**Author:** BenchChem Technical Support Team. **Date:** April 2026

## Compound of Interest

Compound Name: AZD5597

Cat. No.: B1264291

Get Quote

For Researchers, Scientists, and Drug Development Professionals

This guide provides a detailed comparison of the kinase selectivity profiles of two prominent cyclin-dependent kinase (CDK) inhibitors, **AZD5597** and abemaciclib. The information presented herein is intended to support research and drug development efforts by offering a comprehensive overview of their target specificities and the experimental methodologies used to determine them.

## Executive Summary

**AZD5597** is a potent inhibitor of CDK1 and CDK2, suggesting its primary role in regulating the G1/S and G2/M phases of the cell cycle. In contrast, abemaciclib is a highly selective inhibitor of CDK4 and CDK6, key regulators of the G1-S phase transition. While both are CDK inhibitors, their distinct selectivity profiles lead to different mechanisms of action and potential therapeutic applications. Abemaciclib is also known to inhibit other kinases at higher concentrations, indicating a broader spectrum of activity compared to the more targeted profile of **AZD5597**.

## Data Presentation: Kinase Inhibition Profiles

The following table summarizes the in vitro inhibitory potency of **AZD5597** and abemaciclib against various cyclin-dependent kinases and other selected kinases. The data is presented as half-maximal inhibitory concentrations (IC50) or inhibition constants (Ki), providing a quantitative comparison of their selectivity.

Kinase Target	AZD5597 IC50/Ki (nM)	Abemaciclib IC50/Ki (nM)
CDK1/cyclin B	2[1]	>1000[2]
CDK2/cyclin E	2[1]	~300-1000[1]
CDK4/cyclin D1	-	2[1][3]
CDK6/cyclin D3	-	10[1][3]
CDK9	Potent inhibitor[4]	57[1]
GSK3 $\beta$	-	8.67[2]
CAMKII $\delta$	-	2.6[2]
PIM1	-	50[5]
HIPK2	-	31[5]
DYRK2	-	61[5]
CK2	-	117[5]

Note: IC50 and Ki values can vary depending on the specific assay conditions. The data presented is a compilation from multiple sources for comparative purposes.

## Signaling Pathway Diagrams

The distinct selectivity profiles of **AZD5597** and abemaciclib result in their intervention at different points in the cell cycle signaling cascade.

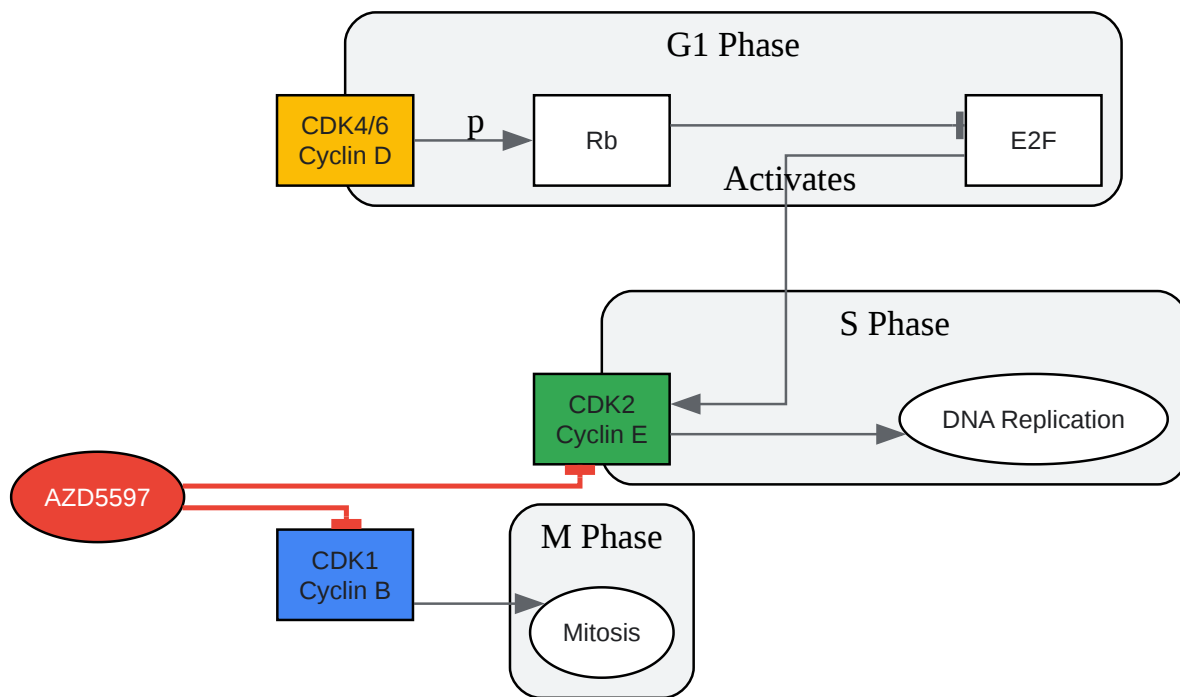

[Click to download full resolution via product page](#)

Caption: **AZD5597** inhibits CDK1 and CDK2, leading to cell cycle arrest at the G1/S and G2/M transitions.

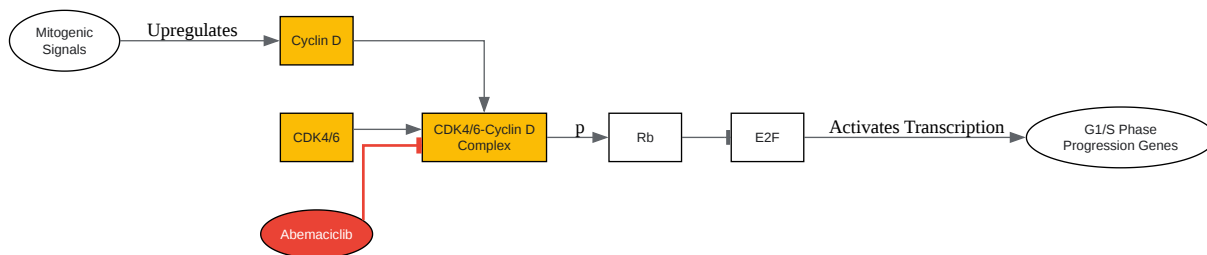

[Click to download full resolution via product page](#)

Caption: Abemaciclib selectively inhibits the CDK4/6-Cyclin D complex, preventing Rb phosphorylation and causing G1 arrest.

## Experimental Protocols

The determination of kinase inhibitor selectivity and potency relies on robust in vitro and cell-based assays. Below are detailed methodologies for key experiments typically employed in the characterization of compounds like **AZD5597** and abemaciclib.

### In Vitro Kinase Inhibition Assay (Radiometric)

This assay quantifies the ability of a compound to inhibit the enzymatic activity of a purified kinase.

Objective: To determine the IC50 value of an inhibitor against a specific kinase.

Materials:

- Purified recombinant kinase (e.g., CDK1/cyclin B, CDK4/cyclin D1)
- Kinase-specific substrate (e.g., Histone H1 for CDK1, Rb protein for CDK4/6)
- [ $\gamma$ -<sup>33</sup>P]ATP (radiolabeled ATP)
- Kinase reaction buffer (e.g., 50 mM HEPES pH 7.5, 10 mM MgCl<sub>2</sub>, 1 mM EGTA, 2 mM DTT, 0.01% Tween-20)
- Test compounds (**AZD5597**, abemaciclib) serially diluted in DMSO
- Phosphocellulose paper (P81)
- 1% Phosphoric acid
- Scintillation counter

Procedure:

- Prepare a reaction mixture containing the purified kinase and its specific substrate in the kinase reaction buffer.

- Add the test compound at various concentrations (typically a 10-point serial dilution) or DMSO as a vehicle control to the reaction mixture.
- Initiate the kinase reaction by adding  $[\gamma\text{-}^{33}\text{P}]\text{ATP}$ .
- Incubate the reaction at 30°C for a specified time (e.g., 30-60 minutes), ensuring the reaction is in the linear range.
- Stop the reaction by spotting a portion of the reaction mixture onto P81 phosphocellulose paper.
- Wash the P81 paper extensively with 1% phosphoric acid to remove unincorporated  $[\gamma\text{-}^{33}\text{P}]\text{ATP}$ .
- Measure the radioactivity retained on the P81 paper using a scintillation counter. This radioactivity is proportional to the amount of phosphorylated substrate.
- Calculate the percentage of kinase inhibition for each compound concentration relative to the DMSO control.
- Determine the IC<sub>50</sub> value by plotting the percentage of inhibition against the logarithm of the inhibitor concentration and fitting the data to a sigmoidal dose-response curve.

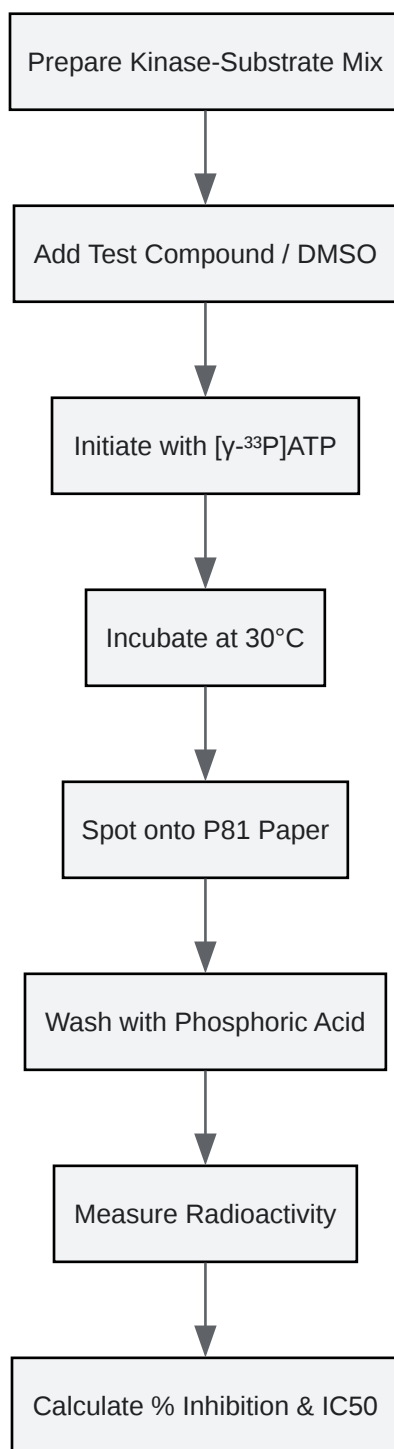

[Click to download full resolution via product page](#)

Caption: Workflow for a radiometric in vitro kinase inhibition assay.

## Cell-Based Proliferation Assay (MTT Assay)

This assay measures the metabolic activity of cells as an indicator of cell viability and proliferation.

Objective: To determine the effect of a compound on the proliferation of cancer cell lines.

Materials:

- Cancer cell line of interest (e.g., MCF-7, HCT116)
- Complete cell culture medium
- Test compounds (**AZD5597**, abemaciclib)
- MTT (3-(4,5-dimethylthiazol-2-yl)-2,5-diphenyltetrazolium bromide) solution
- DMSO
- 96-well microplate
- Microplate reader

Procedure:

- Seed cells in a 96-well plate at a predetermined density and allow them to adhere overnight.
- Treat the cells with serial dilutions of the test compounds or DMSO (vehicle control) for a specified period (e.g., 72 hours).
- After the treatment period, add MTT solution to each well and incubate for 2-4 hours at 37°C. Viable cells with active metabolism will convert MTT into a purple formazan product.
- Remove the medium and dissolve the formazan crystals in DMSO.
- Measure the absorbance of the solution at a specific wavelength (e.g., 570 nm) using a microplate reader.
- Calculate the percentage of cell viability relative to the DMSO-treated control cells.

- Determine the GI50 (concentration for 50% growth inhibition) by plotting cell viability against the logarithm of the compound concentration.

## Cell Cycle Analysis (Flow Cytometry)

This technique is used to determine the distribution of cells in different phases of the cell cycle based on their DNA content.

Objective: To assess the effect of a compound on cell cycle progression.

Materials:

- Cancer cell line
- Test compounds
- Phosphate-buffered saline (PBS)
- Ethanol (70%, ice-cold) for fixation
- Propidium Iodide (PI) staining solution containing RNase A
- Flow cytometer

Procedure:

- Treat cells with the test compound or DMSO for a specific duration (e.g., 24 hours).
- Harvest the cells by trypsinization and wash with PBS.
- Fix the cells by slowly adding them to ice-cold 70% ethanol while vortexing, and incubate at -20°C for at least 2 hours.
- Wash the fixed cells with PBS and resuspend them in PI staining solution.
- Incubate the cells in the dark at room temperature for 30 minutes.
- Analyze the stained cells using a flow cytometer. The fluorescence intensity of PI is proportional to the DNA content.

- The resulting data is displayed as a histogram, from which the percentage of cells in the G0/G1, S, and G2/M phases of the cell cycle can be quantified. An accumulation of cells in a particular phase indicates a cell cycle arrest at that point.

#### Need Custom Synthesis?

BenchChem offers custom synthesis for rare earth carbides and specific isotopic labeling.

Email: [info@benchchem.com](mailto:info@benchchem.com) or [Request Quote Online](#).

## References

- [1. academic.oup.com \[academic.oup.com\]](https://academic.oup.com)
- [2. Competitive Kinase Enrichment Proteomics Reveals that Abemaciclib Inhibits GSK3 \$\beta\$  and Activates WNT Signaling - PMC \[pmc.ncbi.nlm.nih.gov\]](#)
- [3. Inhibiting CDK4/6 in Breast Cancer with Palbociclib, Ribociclib, and Abemaciclib: Similarities and Differences - PMC \[pmc.ncbi.nlm.nih.gov\]](#)
- [4. The discovery of AZD5597, a potent imidazole pyrimidine amide CDK inhibitor suitable for intravenous dosing - PubMed \[pubmed.ncbi.nlm.nih.gov\]](#)
- [5. Frontiers | Identification of abemaciclib derivatives targeting cyclin-dependent kinase 4 and 6 using molecular dynamics, binding free energy calculation, synthesis, and pharmacological evaluation \[frontiersin.org\]](#)
- To cite this document: BenchChem. [AZD5597 vs. Abemaciclib: A Comparative Guide on Kinase Selectivity Profiles]. BenchChem, [2026]. [Online PDF]. Available at: [\[https://www.benchchem.com/product/b1264291/docs#azd5597-vs-abemaciclib-a-comparative-guide-on-kinase-selectivity-profiles\]](https://www.benchchem.com/product/b1264291/docs#azd5597-vs-abemaciclib-a-comparative-guide-on-kinase-selectivity-profiles)

---

### Disclaimer & Data Validity:

The information provided in this document is for Research Use Only (RUO) and is strictly not intended for diagnostic or therapeutic procedures. While BenchChem strives to provide accurate protocols, we make no warranties, express or implied, regarding the fitness of this product for every specific experimental setup.

**Technical Support:** The protocols provided are for reference purposes. Unsure if this reagent suits your experiment?

**Need Industrial/Bulk Grade?** [Request Custom Synthesis Quote](#)

## BenchChem

Our mission is to be the trusted global source of essential and advanced chemicals, empowering scientists and researchers to drive progress in science and industry.

### Contact

Address: 3281 E Guasti Rd  
Ontario, CA 91761, United States  
Phone: (601) 213-4426  
Email: [info@benchchem.com](mailto:info@benchchem.com)

[Contact our Ph.D. Support Team for a compatibility check](#)