

Technical Support Center: Optimizing Spiro[5.5]undecan-3-one Synthesis

Author: BenchChem Technical Support Team. **Date:** April 2026

Compound of Interest

Compound Name: 1,4-Dioxaspiro[5.5]undecan-3-one

CAS No.: 958998-22-6

Cat. No.: B12625309

[Get Quote](#)

Welcome to the technical support center for the synthesis of spiro[5.5]undecan-3-one and its derivatives. This guide is designed for researchers, medicinal chemists, and process development scientists who are working with spirocyclic scaffolds. Here, we provide in-depth troubleshooting advice and frequently asked questions (FAQs) to help you navigate the complexities of temperature optimization for this specific class of molecules. Our focus is on providing not just protocols, but the underlying scientific principles to empower you to make informed decisions in your laboratory work.

The formation of the spiro[5.5]undecane core is a classic transformation, typically achieved through a Robinson annulation. This powerful reaction sequence, which combines a Michael addition with an intramolecular aldol condensation, is elegant in its design but can be sensitive to reaction parameters, especially temperature.^{[1][2]} An improperly controlled thermal environment can lead to a host of issues, including low yields, the formation of difficult-to-separate byproducts, and even complete reaction failure. This guide will help you diagnose and resolve these temperature-related challenges.

Troubleshooting Guide: Temperature-Related Issues

This section addresses specific problems you may encounter during the synthesis of spiro[5.5]undecan-3-one, with a focus on how temperature adjustments can provide a solution.

Issue 1: Low to No Yield of the Desired Spiro[5.5]undecan-3-one

Q: My reaction is not producing the expected spirocyclic ketone, or the yield is significantly lower than anticipated. How can temperature be the culprit?

A: This is a common and frustrating issue that can often be traced back to suboptimal temperature control at one or more stages of the Robinson annulation sequence.

Potential Causes & Solutions:

- Cause A: Michael Addition Not Initiating (Too Low Temperature). The initial Michael addition of your cyclohexanone derivative to an α,β -unsaturated ketone (like methyl vinyl ketone) may have too high of an activation energy to proceed at very low temperatures. While some reactions are run at room temperature (23 °C), if no product formation is observed, a modest increase in temperature may be required.^[3]
 - Solution: Monitor the reaction by Thin Layer Chromatography (TLC) or Liquid Chromatography-Mass Spectrometry (LC-MS). If no consumption of the starting material is observed after a reasonable time, consider gently warming the reaction to 30-40 °C. Avoid aggressive heating, as this can trigger side reactions.
- Cause B: Inefficient Annulation (Incorrect Temperature for Aldol Condensation). The second step, the intramolecular aldol condensation and subsequent dehydration, is highly temperature-dependent.^[4]
 - Solution: This step often requires heating (reflux) to drive the cyclization and dehydration to completion.^[5] If you have successfully formed the Michael adduct (the intermediate 1,5-diketone) but are not seeing the final spirocyclic product, a systematic increase in temperature is warranted. It is advisable to perform temperature screening experiments in small-scale parallel reactions.
- Cause C: Decomposition of Reagents or Product (Too High Temperature). Excessive heat can be just as detrimental as insufficient heat. Methyl vinyl ketone is prone to polymerization

at higher temperatures, and the final product or intermediates may not be stable under harsh reflux conditions for extended periods.[4][6]

- Solution: If you observe the formation of insoluble polymeric material or a complex mixture of degradation products, the reaction temperature is likely too high.[7] Reduce the temperature or consider a milder catalyst that may allow the reaction to proceed at a lower temperature. For instance, some modern organocatalytic methods for similar annulations can be run effectively at temperatures from room temperature to 60 °C.[8]

Data-Driven Temperature Optimization

To systematically optimize the temperature for the crucial aldol condensation step, consider the following experimental design.

Parameter	Experiment 1 (Low Temp)	Experiment 2 (Mid Temp)	Experiment 3 (High Temp)
Temperature	Room Temperature (~25 °C)	60 °C	Reflux (e.g., Toluene, ~110 °C)
Reaction Time	24 hours	12 hours	6 hours
Expected Outcome	Incomplete reaction, Michael adduct may be present.	Potential for good conversion to product.	Risk of byproduct formation/decomposition.
Analysis	TLC, LC-MS, ¹ H NMR of crude mixture	TLC, LC-MS, ¹ H NMR of crude mixture	TLC, LC-MS, ¹ H NMR of crude mixture

This structured approach allows you to quickly identify a promising temperature window for your specific substrate and catalyst system.

Issue 2: Formation of Significant Byproducts

Q: My reaction produces a complex mixture, and isolating the desired spiro[5.5]undecan-3-one is a major challenge. How does temperature influence selectivity?

A: Temperature is a key driver of reaction selectivity. By controlling it precisely, you can favor the desired intramolecular pathway over competing intermolecular side reactions.

Potential Causes & Solutions:

- Cause A: Self-Condensation of Starting Materials. At elevated temperatures, the starting cyclohexanone derivative can undergo self-aldol condensation, leading to dimeric impurities.
 - Solution: Maintain a lower temperature during the initial Michael addition phase. Often, adding the base or catalyst at a reduced temperature (e.g., 0 °C) before allowing the reaction to slowly warm can suppress this side reaction.[7]
- Cause B: Polymerization of the Michael Acceptor. As mentioned, α,β -unsaturated ketones like methyl vinyl ketone can polymerize, especially when heated in the presence of base or acid catalysts.[6]
 - Solution: Keep the reaction temperature as low as possible while still ensuring a reasonable reaction rate. Adding the Michael acceptor slowly over a period of time can also help to keep its instantaneous concentration low, thus minimizing polymerization.
- Cause C: Formation of the Aldol Addition Product without Dehydration. You may isolate the intermediate hydroxy ketone (the aldol adduct) without the final dehydration to the enone.
 - Solution: This indicates that the temperature is not high enough to drive the elimination of water.[9] Increasing the temperature or switching to a solvent that allows for azeotropic removal of water (e.g., using a Dean-Stark apparatus with toluene) can facilitate this final dehydration step.[10]

Visualizing the Troubleshooting Workflow

A logical approach is essential when diagnosing reaction issues. The following diagram outlines a workflow for troubleshooting common temperature-related problems in spiro[5.5]undecan-3-one synthesis.

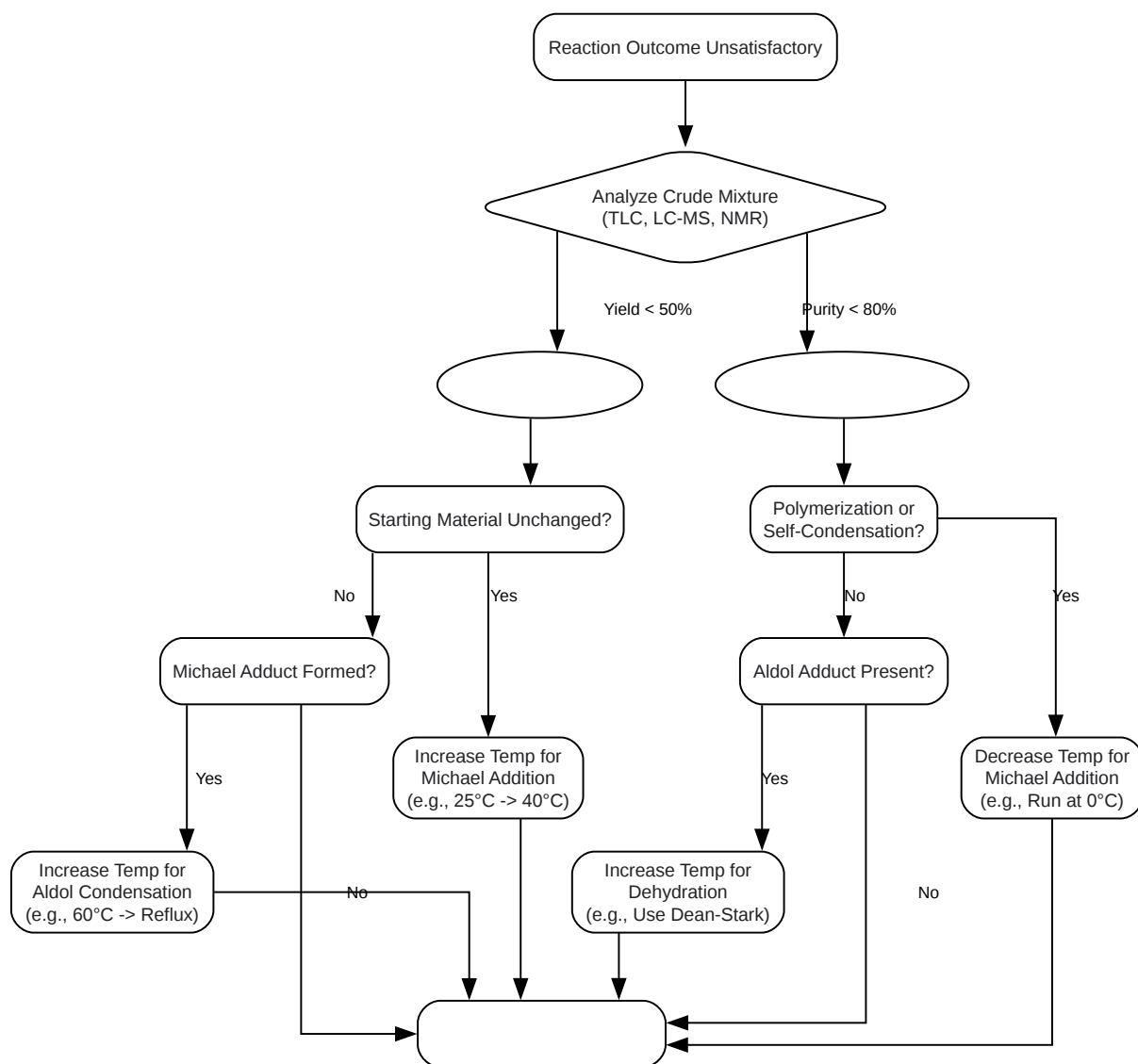

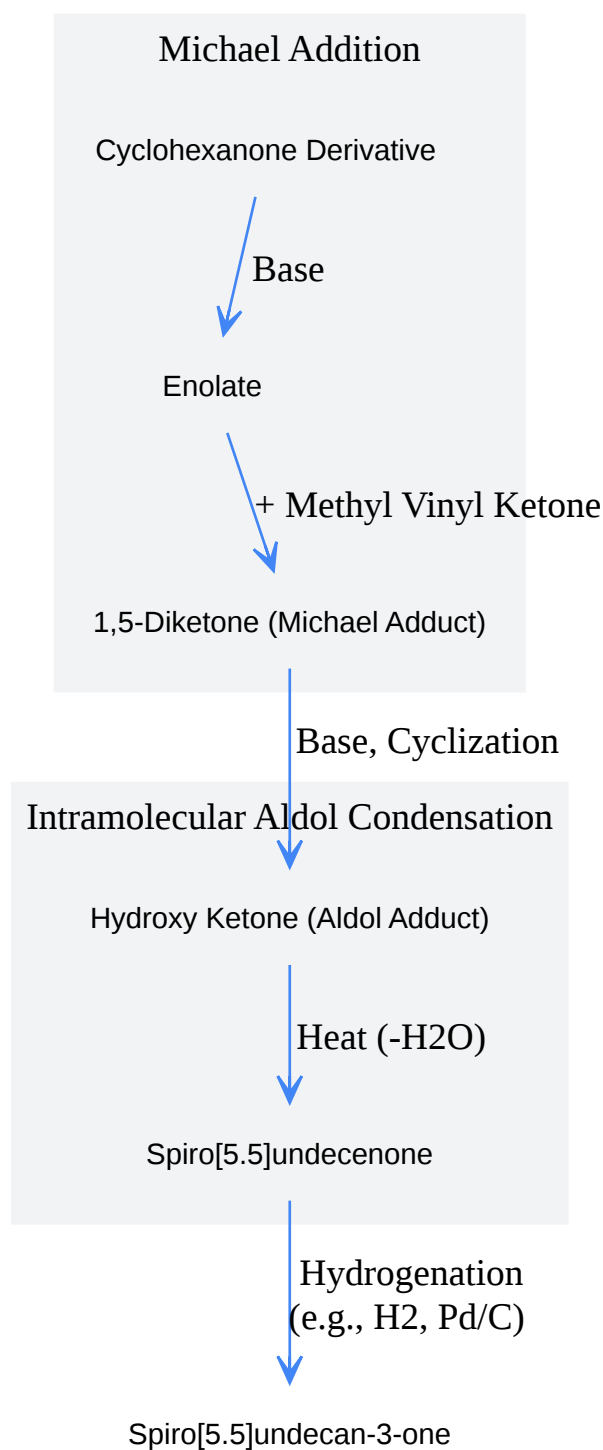

[Click to download full resolution via product page](#)

Caption: Reaction pathway for spiroketone synthesis.

Q2: Should I use acidic or basic conditions, and how does that choice impact the optimal temperature?

A2: The choice between acidic and basic catalysis is crucial and substrate-dependent. * Basic Conditions (e.g., NaOMe, KOH, Triton B): These are the classic conditions. They are very effective at generating the initial enolate for the Michael addition. However, they can also promote polymerization of MVK. The aldol condensation is also base-catalyzed, but the final dehydration step often requires heat. * Acidic Conditions (e.g., H₂SO₄, p-TsOH): Acid catalysis proceeds via an enol intermediate. While sometimes offering milder conditions, the reactions can be slower and may require higher temperatures to achieve reasonable rates. [6] However, acidic conditions can be very effective at promoting the final dehydration step.

Generally, basic reactions may start at lower temperatures for the Michael addition, followed by heating for the cyclization. Acid-catalyzed reactions might be run at a constant, elevated temperature from the start.

Q3: My reaction stalls and does not go to completion, even at reflux. What should I do?

A3: A stalled reaction suggests that the activation energy for the rate-limiting step is not being overcome, or a catalyst has been deactivated.

- **Verify Catalyst Activity:** Ensure your base or acid catalyst has not been neutralized or degraded.
- **Increase Temperature (with caution):** If using a solvent like THF or methanol, consider switching to a higher-boiling solvent like toluene or xylene to access higher temperatures. However, perform a small-scale test reaction first to check for product decomposition at these higher temperatures. [7] * **Consider a Different Catalyst:** If thermal promotion is not working, the issue may be catalytic. For example, proline and its derivatives have been used as organocatalysts in Robinson annulations, sometimes achieving high yields under relatively mild heating (e.g., 60 °C). [8]

A4: A parallel reactor system is ideal, but if unavailable, you can run sequential experiments.

- **Establish a Baseline:** Run the reaction at the literature-reported temperature or at room temperature as a starting point.

- Define a Range: Based on the baseline result, define a temperature range to screen (e.g., 30 °C, 50 °C, 70 °C, 90 °C).
- Maintain Consistency: Keep all other variables (concentration, stoichiometry, solvent, stirring speed) identical across all experiments.
- Monitor Progress: Take samples at regular intervals (e.g., 1h, 3h, 6h, 12h) from each reaction and analyze by TLC or LC-MS to build a reaction profile (conversion vs. time) at each temperature.
- Analyze and Select: Choose the temperature that gives the best balance of reaction rate, yield, and purity.

Experimental Workflow: Temperature Screening

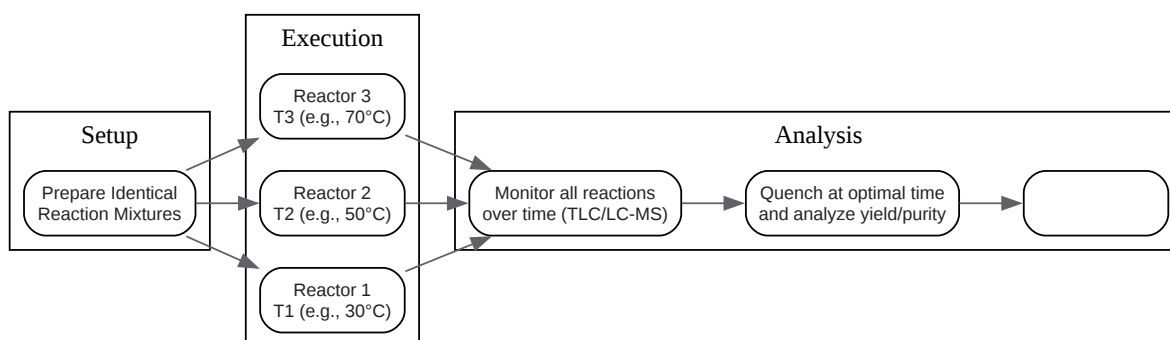

[Click to download full resolution via product page](#)

Caption: Protocol for systematic temperature optimization.

References

Need Custom Synthesis?

BenchChem offers custom synthesis for rare earth carbides and specific isotopic labeling.

Email: info@benchchem.com or [Request Quote Online](#).

Sources

- [1. masterorganicchemistry.com](https://www.masterorganicchemistry.com) [[masterorganicchemistry.com](https://www.masterorganicchemistry.com)]
- [2. Robinson annulation - Wikipedia](https://en.wikipedia.org) [en.wikipedia.org]
- [3. pdf.benchchem.com](https://pdf.benchchem.com) [pdf.benchchem.com]
- [4. pdf.benchchem.com](https://pdf.benchchem.com) [pdf.benchchem.com]
- [5. pdf.benchchem.com](https://pdf.benchchem.com) [pdf.benchchem.com]
- [6. juniperpublishers.com](https://www.juniperpublishers.com) [[juniperpublishers.com](https://www.juniperpublishers.com)]
- [7. pdf.benchchem.com](https://pdf.benchchem.com) [pdf.benchchem.com]
- [8. Thieme E-Journals - Synthesis / Abstract](https://thieme-connect.com) [thieme-connect.com]
- [9. youtube.com](https://www.youtube.com) [[youtube.com](https://www.youtube.com)]
- [10. scholarworks.uni.edu](https://scholarworks.uni.edu) [scholarworks.uni.edu]
- To cite this document: BenchChem. [Technical Support Center: Optimizing Spiro[5.5]undecan-3-one Synthesis]. BenchChem, [2026]. [Online PDF]. Available at: [<https://www.benchchem.com/product/b12625309/docs#technical-support-center-optimizing-spiro-5-5-undecan-3-one-synthesis>]

Disclaimer & Data Validity:

The information provided in this document is for Research Use Only (RUO) and is strictly not intended for diagnostic or therapeutic procedures. While BenchChem strives to provide accurate protocols, we make no warranties, express or implied, regarding the fitness of this product for every specific experimental setup.

Technical Support: The protocols provided are for reference purposes. Unsure if this reagent suits your experiment?

Need Industrial/Bulk Grade? [Request Custom Synthesis Quote](#)

BenchChem

Our mission is to be the trusted global source of essential and advanced chemicals, empowering scientists and researchers to drive progress in science and industry.

Contact

Address: 3281 E Guasti Rd

Ontario, CA 91761, United States

Phone: (601) 213-4426

Email: info@benchchem.com

[Contact our Ph.D. Support Team for a compatibility check](#)