

Application Notes & Protocols: Microwave-Assisted Synthesis of Quinazoline Compounds

Author: BenchChem Technical Support Team. **Date:** April 2026

Compound of Interest

Compound Name: *Ethyl 6-methylquinazoline-1(2H)-carboxylate*

CAS No.: 919769-95-2

Cat. No.: B12612845

[Get Quote](#)

Abstract

This guide provides a comprehensive overview and detailed protocols for the microwave-assisted synthesis of quinazoline and quinazolinone derivatives, scaffolds of significant interest in medicinal chemistry and drug development. Microwave-assisted organic synthesis (MAOS) offers a transformative approach to traditional synthetic methods, delivering substantial improvements in reaction times, yields, and overall efficiency while aligning with the principles of green chemistry.^{[1][2][3][4][5]} This document elucidates the fundamental principles of microwave heating, presents validated, step-by-step protocols for key synthetic transformations, and offers expert insights into experimental design and troubleshooting. It is intended for researchers, scientists, and professionals in drug development seeking to leverage this powerful technology for the rapid and efficient synthesis of quinazoline libraries.

Introduction: The Quinazoline Scaffold and the Microwave Advantage

The quinazoline ring system is a privileged scaffold in medicinal chemistry, forming the core of numerous compounds with a wide spectrum of biological activities, including anticancer, anti-inflammatory, antibacterial, and anticonvulsant properties.[6][7] The urgent demand for novel therapeutic agents necessitates the rapid synthesis and screening of large libraries of these compounds.

Traditional methods for quinazoline synthesis often involve lengthy reaction times, high temperatures, and the use of hazardous solvents, which can limit the efficiency of the drug discovery process.[1][8] Microwave-assisted synthesis has emerged as a powerful and sustainable alternative, revolutionizing the field by offering several key advantages:[3][5][9][10]

- **Dramatic Rate Acceleration:** Reactions that take hours or days under conventional heating can often be completed in minutes.[3][9][10]
- **Enhanced Yields and Purity:** Rapid, uniform heating often leads to higher conversion rates and fewer by-products, simplifying purification.[3][5][11]
- **Energy Efficiency:** Microwaves heat the reactants directly, avoiding the need to heat the entire reaction vessel, thus conserving energy.[2][4]
- **Alignment with Green Chemistry:** MAOS frequently allows for solvent-free reactions or the use of more environmentally benign solvents, reducing hazardous waste.[2][4][12]

Fundamental Principles of Microwave Heating

Unlike conventional heating which relies on slow conduction and convection, microwave energy heats a sample through direct coupling with polar molecules and ionic species within the reaction mixture.[2][13] This volumetric heating is primarily driven by two mechanisms:

- **Dipolar Polarization:** Polar molecules, possessing a permanent dipole moment, attempt to align with the rapidly oscillating electric field of the microwave. This constant reorientation generates friction, leading to rapid and efficient heating.[2][4][13] Solvents with high dielectric constants (e.g., DMSO, DMF, ethanol) are excellent microwave absorbers.[13]
- **Ionic Conduction:** In the presence of ions, the oscillating electric field induces ionic migration. Collisions between these moving ions generate heat.[4][13]

This direct energy transfer allows for temperatures to be reached that are difficult to achieve with conventional heating, often leading to different reaction pathways and improved outcomes.

[2][4]

Experimental Workflows and Protocols

The following section details validated, step-by-step protocols for the microwave-assisted synthesis of quinazoline derivatives. These methods have been selected for their reliability, efficiency, and broad applicability.

Workflow Overview: Microwave-Assisted Reaction Setup

The general workflow for performing a microwave-assisted synthesis is straightforward and depicted below. Modern dedicated microwave reactors offer precise control over temperature, pressure, and power, ensuring reproducibility and safety.

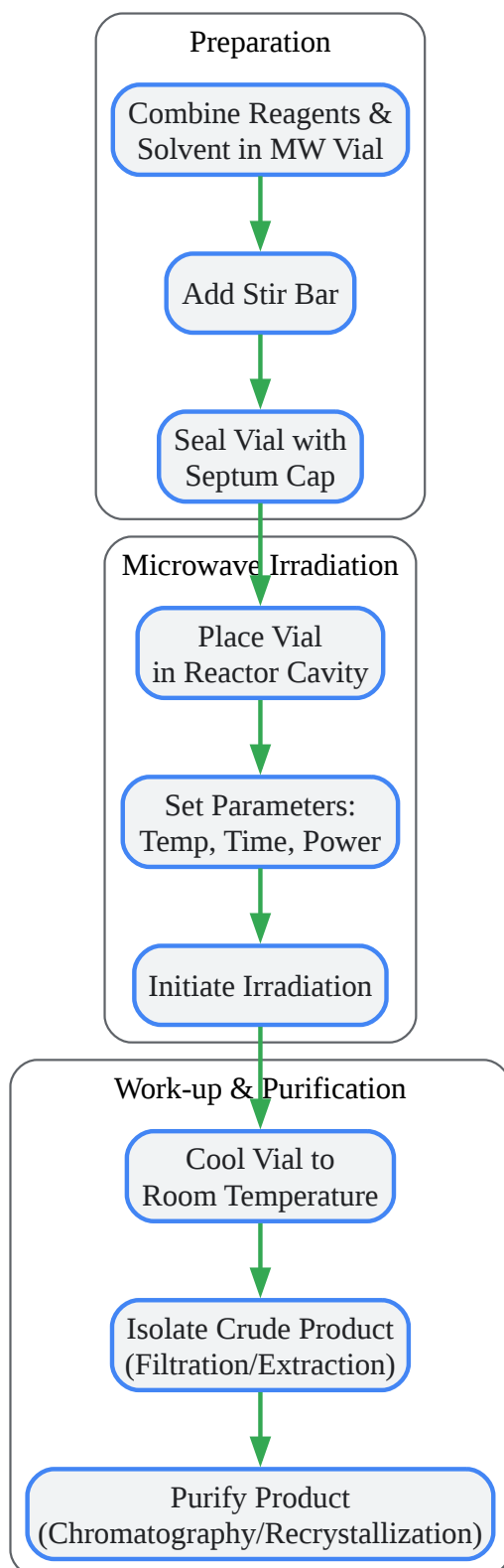

[Click to download full resolution via product page](#)

Caption: General workflow for a microwave-assisted synthesis experiment.

Protocol 1: One-Pot Synthesis of 2,3-Disubstituted 4(3H)-Quinazolinones

This protocol details a highly efficient, one-pot, two-step synthesis from readily available starting materials. It is particularly valuable for generating diverse libraries for screening.^{[8][14]}

Scientific Rationale: This method leverages the ability of microwave irradiation to first drive the condensation of an anthranilic acid and a carboxylic acid to form a benzoxazinone intermediate. Without isolation, a primary amine is added, and a second microwave heating step rapidly forms the final quinazolinone. The high temperatures achieved under microwave conditions (up to 250°C) are crucial for the efficiency of the second step.^[14]

Reaction Scheme:

The image you are requesting does not exist or is no longer available.

imgur.com

(Self-generated image, not from search results)

Materials:

- Anthranilic acid (1.0 mmol)
- Carboxylic acid (or acyl chloride) (1.1 mmol)
- Primary amine (1.2 mmol)
- Microwave reactor vials (10 mL) with stir bars
- Microwave synthesizer

Procedure:

- In a 10 mL microwave reactor vial, combine the anthranilic acid (1.0 mmol) and the carboxylic acid (1.1 mmol).
- Seal the vial securely with a septum cap.

- Place the vial in the microwave synthesizer cavity.
- Irradiate the mixture at 150 °C for 10 minutes. Use temperature control and a maximum power setting of 300 W.
- After the first irradiation step, allow the vial to cool to room temperature (below 50°C).
- Carefully unseal the vial and add the primary amine (1.2 mmol) to the reaction mixture.
- Reseal the vial and place it back into the microwave synthesizer.
- Irradiate the mixture at 250 °C for 3-6 minutes.[8][14]
- Once the reaction is complete, cool the vial to room temperature.
- Isolate the crude product. This may involve adding a solvent like ethanol to precipitate the solid, followed by filtration, or performing a standard liquid-liquid extraction.
- Purify the final 2,3-disubstituted 4(3H)-quinazolinone product by column chromatography on silica gel or recrystallization.

Protocol 2: Solvent-Free Synthesis of 2-Substituted Quinazolin-4(3H)-ones

This protocol exemplifies a green chemistry approach, utilizing a catalyst under solvent-free conditions to produce 2-substituted quinazolinones.[7]

Scientific Rationale: This method involves the condensation of anthranilamide with an aldehyde or ketone. The use of a Lewis acid catalyst, such as Antimony(III) chloride (SbCl_3), activates the carbonyl group, facilitating the initial condensation.[7] Microwave irradiation under solvent-free conditions provides rapid, efficient heating of the solid reactants, promoting cyclization and dehydration to afford the quinazolinone product in minutes.[7]

Reaction Scheme:

 alt text (Self-generated image, not from search results)

Materials:

- Anthranilamide (2 mmol)
- Aldehyde or ketone (2 mmol)
- Antimony(III) chloride (SbCl_3) (1 mol%, ~0.02 mmol)
- Microwave reactor equipped with a condenser (for open-vessel option) or sealed vials
- Mortar and pestle

Procedure:

- In a mortar, thoroughly mix the anthranilamide (2 mmol), the aldehyde or ketone (2 mmol), and SbCl_3 (1 mol%).
- Transfer the solid mixture into a microwave-safe reaction vessel.
- Place the vessel in the microwave reactor.
- Irradiate the mixture for 3–5 minutes using a microwave power of 200 W.^[7] It has been noted that higher power levels may decrease the yield.^[7]
- After irradiation, allow the mixture to cool to room temperature.
- Add water to the reaction vessel. The product will typically precipitate.
- Collect the solid product by filtration and wash it thoroughly with water.
- Recrystallize the crude product from ethanol to obtain the pure 2-substituted quinazolin-4(3H)-one.

Data Presentation and Comparison

The advantages of microwave-assisted synthesis are most evident when compared directly with conventional heating methods.

Table 1: Comparison of Conventional vs. Microwave Synthesis for Quinazolin-4(3H)-ones

Reaction	Method	Catalyst/Solvent	Time	Yield (%)	Reference(s)
Anthranilamide + Benzaldehyde	Conventional	SbCl ₃ / Heat	3-5 hours	72	[7]
Anthranilamide + Benzaldehyde	Microwave	SbCl ₃ / Solvent-Free	3-5 min	94	[7]
Anthranilic Acid + Formamide (Niementowski Reaction)	Conventional	High Temperature	Several hours	Moderate	[1]
Anthranilic Acid + Formamide (Niementowski Reaction)	Microwave	Montmorillonite K-10 / Solvent-Free	4 min	~90	[1]
2-Aminobenzamide + Benzyl Alcohol	Conventional	CuI, Cs ₂ CO ₃ / Oil Bath (130°C)	16 hours	55	[15]
2-Aminobenzamide + Benzyl Alcohol	Microwave	CuI, Cs ₂ CO ₃ / Solvent-Free (130°C)	2 hours	>80	[15]

Troubleshooting and Expert Insights

Even with optimized protocols, challenges can arise. Below is a logical approach to troubleshooting common issues in microwave-assisted quinazoline synthesis.

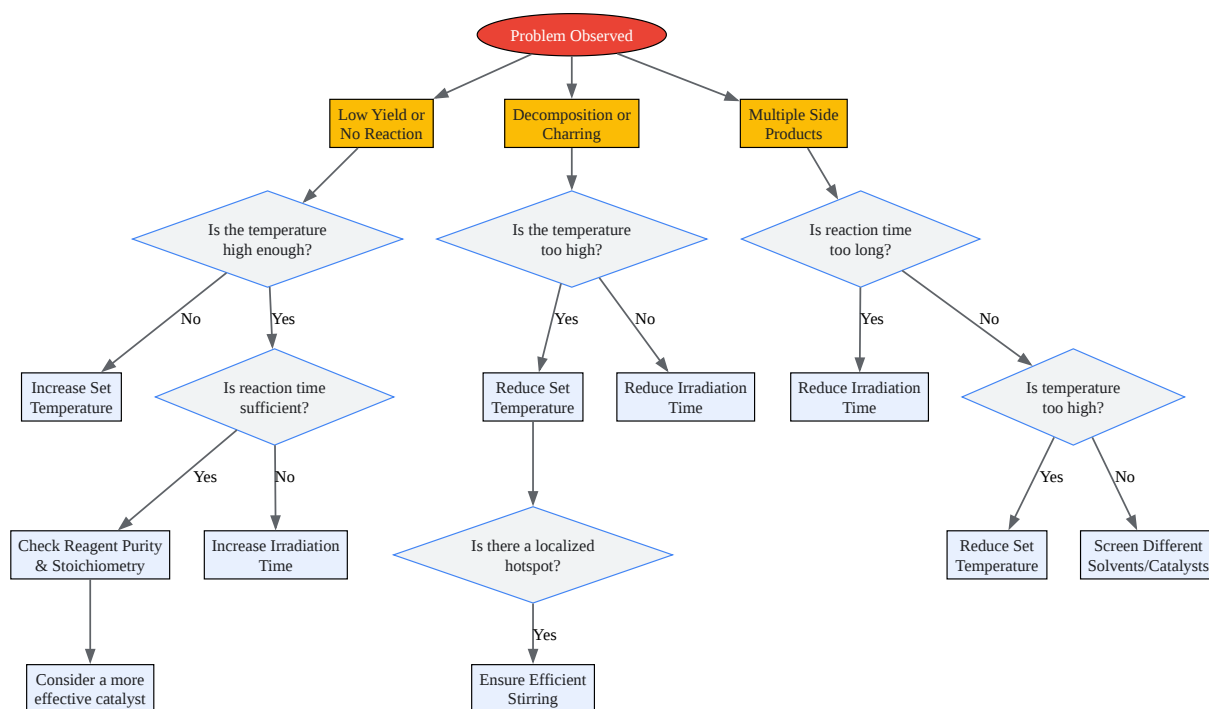

[Click to download full resolution via product page](#)

Caption: A decision-making flowchart for troubleshooting common issues.

Causality Behind Experimental Choices:

- **Solvent Selection:** Choose solvents that are not only appropriate for the reaction chemistry but also good microwave absorbers (e.g., DMSO, DMF, ethanol, NMP).[13] For solvent-free reactions, ensure the reactants themselves can absorb microwave energy or that a catalytic amount of a polar substance is present.
- **Vessel Choice:** Always use appropriate, pressure-rated sealed vessels for reactions involving volatile solvents or where temperatures will exceed the solvent's boiling point. This is critical for safety and for reaching the superheated conditions that accelerate reactions.
- **Power vs. Temperature Control:** Modern reactors primarily use temperature control. The instrument automatically modulates power to maintain the set temperature. Using a fixed, lower power can sometimes prevent overheating and decomposition, as seen in Protocol 2.
[7]

Conclusion

Microwave-assisted synthesis represents a cornerstone of modern synthetic chemistry, offering unparalleled speed, efficiency, and control for the construction of valuable heterocyclic frameworks like quinazolines.[9][16][17] By supplanting traditional, time-consuming methods, MAOS accelerates the drug discovery and development pipeline, enabling faster lead generation and optimization. The protocols and insights provided in this guide serve as a robust foundation for researchers to successfully implement and innovate within this exciting field.

References

- Zahra, et al. (2020). Microwave-Assisted Synthesis of Quinazolines and Quinazolinones: An Overview. *Frontiers in Chemistry*. Available at: [\[Link\]](#)
- Amrutkar, et al. (2018). Microwave Assisted Synthesis and Molecular Docking Studies of 3-Aryl-2-Alkyl-Quinazolin-4-one Derivatives. *Scholars Research Library*. Available at: [\[Link\]](#)

- Dabholkar, et al. (2007). Microwave assisted synthesis of triazoloquinazolinones and benzimidazoquinazolinones. Beilstein Journal of Organic Chemistry. Available at: [\[Link\]](#)
- Besson, T. (2007). Microwave-Assisted Synthesis of Bioactive Quinazolines and Quinazolinones. Current Computer-Aided Drug Design. Available at: [\[Link\]](#)
- Wang, et al. (2015). Microwave-assisted synthesis of quinazolin-4(3H)-ones catalyzed by SbCl₃. De Gruyter. Available at: [\[Link\]](#)
- Gadek, et al. (2025). Microwave-Assisted Organic Synthesis: An Eco-Friendly Method of Green Chemistry. MDPI. Available at: [\[Link\]](#)
- European Pharmaceutical Contractor (2024). Microwave-Assisted Synthesis in Drug Development. EPCP. Available at: [\[Link\]](#)
- Komar, M., et al. (2020). Green chemistry approach to the synthesis of 3-substituted-quinazolin-4(3H)-ones and 2-methyl-3-substituted-quinazolin-4(3H)-ones and biological evaluation. Taylor & Francis Online. Available at: [\[Link\]](#)
- Komar, M., et al. (2020). Green chemistry approach to the synthesis of 3-substituted-quinazolin-4(3H)-ones and 2-methyl-3-substituted-quinazolin-4(3H)-ones and biological evaluation. ResearchGate. Available at: [\[Link\]](#)
- Wang, et al. (2014). Synthesis of 2-substituted quinazolines by CsOH-mediated direct aerobic oxidative cyclocondensation of 2-aminoarylmethanols with nitriles in air. Green Chemistry. Available at: [\[Link\]](#)
- Tanimu, et al. (2022). Metal-Free Synthesis of 2-Substituted Quinazolines via Green Oxidation of o-Aminobenzylamines. Frontiers in Chemistry. Available at: [\[Link\]](#)
- Ferrini, S., et al. (2007). Convenient Synthetic Approach to 2,4-Disubstituted Quinazolines. Organic Chemistry Portal. Available at: [\[Link\]](#)
- Lou, J. (2002). Microwave Assisted Organic Synthesis. University of Pennsylvania. Available at: [\[Link\]](#)

- Kappe, C. O., & Dallinger, D. (2006). The impact of microwave synthesis on drug discovery. Nature Reviews Drug Discovery. Available at: [\[Link\]](#)
- Unknown (n.d.). Role of Microwave in Pharmaceutical Sciences. ANU BOOKS PUBLISHER & DISTRIBUTOR. Available at: [\[Link\]](#)
- Kaewmati, P., et al. (2018). Microwave-assisted commercial copper-catalyzed aerobic oxidative synthesis of AChE quinazolinone inhibitors under solvent free conditions. RSC Advances. Available at: [\[Link\]](#)
- Sharma, V. (2024). Microwaves in Organic Synthetic Chemistry- A Greener Approach to Environmental Protection: An Overview. International Journal of Advanced Research. Available at: [\[Link\]](#)
- Postigo, A., et al. (2009). Microwave-assisted synthesis in aqueous medium of new quinazoline derivatives as anticancer agent precursors. Green Chemistry. Available at: [\[Link\]](#)
- Unknown (2023). MICROWAVE ASSISTED ORGANIC SYNTHESIS: A GREEN CHEMISTRY APPROACH. IJNRD.org. Available at: [\[Link\]](#)
- Behera, K., & Behera, A. (2016). Microwave Assisted Synthesis of Organic Compounds and Nanomaterials. ResearchGate. Available at: [\[Link\]](#)
- Wang, et al. (2010). Solvent-free synthesis of quinazolin-4(3H)-ones promoted by SbCl₃ under microwave condition. Indian Journal of Chemistry. Available at: [\[Link\]](#)
- CEM Corporation (2025). Drug Discovery at the Speed of Light. CEM. Available at: [\[Link\]](#)
- Meshram, J. (2019). Importance of Microwave Heating in Organic Synthesis. Advanced Journal of Chemistry, Section A. Available at: [\[Link\]](#)
- Unknown (2021). A Review on 4(3H)-quinazolinone synthesis. International Journal of Pharmaceutical Research and Applications. Available at: [\[Link\]](#)
- Unknown (2024). Green Synthesis of Octahydroquinazolinones via Microwave-Assisted One-Pot Reaction with Ammonium Metavanadate. International Journal For Advanced Research In Science & Technology. Available at: [\[Link\]](#)

- de la Cruz, P., et al. (2007). Microwave-Assisted, Solvent-Free Synthesis of Several Quinazoline Alkaloid Frameworks. The Journal of Organic Chemistry. Available at: [\[Link\]](#)
- Hulme, C., et al. (2003). One-pot microwave assisted preparation of pyrazoloquinazolinone libraries. Molecular Diversity. Available at: [\[Link\]](#)
- Zahra, et al. (2020). Microwave-Assisted Synthesis of Quinazolines and Quinazolinones: An Overview. PubMed. Available at: [\[Link\]](#)
- Zahra, et al. (2020). Microwave-Assisted Synthesis of Quinazolines and Quinazolinones: An Overview. Frontiers. Available at: [\[Link\]](#)
- Kaewmati, P., et al. (2018). Microwave-assisted commercial copper-catalyzed aerobic oxidative synthesis of AChE quinazolinone inhibitors under solvent free c. Semantic Scholar. Available at: [\[Link\]](#)
- Li, Z., et al. (2008). Microwave-Assisted Efficient and Convenient Synthesis of 2,4(1H,3H)-Quinazolinediones and 2-Thioxoquinazolines. CoLab.ws. Available at: [\[Link\]](#)
- Li, Z., et al. (2008). Microwave-assisted efficient and convenient synthesis of 2,4(1H,3H)-quinazolinediones and 2-thioxoquinazolines. PubMed. Available at: [\[Link\]](#)
- Unknown (n.d.). Novel Microwave Assisted Synthesis of Some 3- $\{$ -2 (1H4 ,2 ,1 -triazolyl) ethyl $\}$ -2- Substituted Quinazolinone Analogues and Their Evaluation for Antimicrobial Potential. Journal of Drug Delivery and Therapeutics. Available at: [\[Link\]](#)
- Zahra, et al. (2025). (PDF) Microwave-Assisted Synthesis of Quinazolines and Quinazolinones: An Overview. ResearchGate. Available at: [\[Link\]](#)

Need Custom Synthesis?

BenchChem offers custom synthesis for rare earth carbides and specific isotopic labeling.

Email: info@benchchem.com or [Request Quote Online](#).

Sources

- [1. Microwave-Assisted Synthesis of Quinazolines and Quinazolinones: An Overview - PMC \[pmc.ncbi.nlm.nih.gov\]](#)
- [2. mdpi.com \[mdpi.com\]](#)
- [3. epcp.ac.in \[epcp.ac.in\]](#)
- [4. ajgreenchem.com \[ajgreenchem.com\]](#)
- [5. ajchem-a.com \[ajchem-a.com\]](#)
- [6. BJOC - Microwave assisted synthesis of triazoloquinazolinones and benzimidazoquinazolinones \[beilstein-journals.org\]](#)
- [7. scispace.com \[scispace.com\]](#)
- [8. pdf.benchchem.com \[pdf.benchchem.com\]](#)
- [9. The impact of microwave synthesis on drug discovery - PubMed \[pubmed.ncbi.nlm.nih.gov\]](#)
- [10. anubooks.com \[anubooks.com\]](#)
- [11. scholarsresearchlibrary.com \[scholarsresearchlibrary.com\]](#)
- [12. ijnrd.org \[ijnrd.org\]](#)
- [13. visitka.narod.ru \[visitka.narod.ru\]](#)
- [14. ijprajournal.com \[ijprajournal.com\]](#)
- [15. Microwave-assisted commercial copper-catalyzed aerobic oxidative synthesis of AChE quinazolinone inhibitors under solvent free conditions - PMC \[pmc.ncbi.nlm.nih.gov\]](#)
- [16. benthamdirect.com \[benthamdirect.com\]](#)
- [17. Microwave-Assisted Synthesis of Quinazolines and Quinazolinones: An Overview - PubMed \[pubmed.ncbi.nlm.nih.gov\]](#)
- [To cite this document: BenchChem. \[Application Notes & Protocols: Microwave-Assisted Synthesis of Quinazoline Compounds\]. BenchChem, \[2026\]. \[Online PDF\]. Available at: \[https://www.benchchem.com/product/b12612845/docs#application-notes-protocols-microwave-assisted-synthesis-of-quinazoline-compounds\]](#)

Disclaimer & Data Validity:

The information provided in this document is for Research Use Only (RUO) and is strictly not intended for diagnostic or therapeutic procedures. While BenchChem strives to provide

accurate protocols, we make no warranties, express or implied, regarding the fitness of this product for every specific experimental setup.

Technical Support: The protocols provided are for reference purposes. Unsure if this reagent suits your experiment?

Need Industrial/Bulk Grade? [Request Custom Synthesis Quote](#)

BenchChem

Our mission is to be the trusted global source of essential and advanced chemicals, empowering scientists and researchers to drive progress in science and industry.

Contact

Address: 3281 E Guasti Rd

Ontario, CA 91761, United States

Phone: (601) 213-4426

Email: info@benchchem.com

[Contact our Ph.D. Support Team for a compatibility check](#)