

In Vitro Biological Activity of Potassium Taurate: A Technical Guide

Author: BenchChem Technical Support Team. **Date:** April 2026

Compound of Interest

Compound Name: *Potassium taurate*

CAS No.: 22890-34-2

Cat. No.: B1261178

[Get Quote](#)

For Researchers, Scientists, and Drug Development Professionals

Introduction: Taurine, a β -amino acid, is one of the most abundant free amino acids in mammalian tissues, playing a crucial role in numerous physiological processes. While often studied as a standalone molecule, its salt form, **potassium taurate**, is relevant in various physiological and experimental contexts where potassium is the predominant cation. This technical guide provides an in-depth overview of the in vitro biological activities attributed to taurine, with the understanding that in aqueous solutions, it exists in equilibrium with its corresponding ions. The focus is on its effects on ion channels, cellular signaling pathways, and its antioxidant and anti-inflammatory properties.

Modulation of Ion Channels

Taurine has been shown to modulate the activity of several ion channels, particularly potassium (K^+) and calcium (Ca^{2+}) channels, which are fundamental to cellular excitability and signaling.

1.1. Potassium Channel Activity

Taurine exhibits complex, context-dependent effects on various potassium channels. In retinal neurons, taurine enhances the outward delayed-rectifier K⁺ currents, specifically targeting the Kv1.3 subtype.^[1] This effect is not observed in all retinal cell types, being preferential to OFF-bipolar cells.^[1] The mechanism of this enhancement is indirect, involving a metabotropic signaling pathway.^{[1][2]}

In cardiac muscle cells, the effects of taurine on potassium channels are multifaceted. It has been reported to inhibit the delayed rectifier K⁺ current (I_{Krec}) at high intracellular calcium concentrations and enhance the transient outward current (I_{to}).^[3] Furthermore, taurine can inhibit the ATP-sensitive K⁺ current (I_{K(ATP)}).^[3] Studies on human radial artery preparations suggest that taurine's relaxant effect is mediated through the opening of large conductance Ca²⁺-activated K⁺ channels (BKCa).^[4]

Quantitative Data on Taurine's Effect on Ion Channels

Parameter	Effect	Concentration	Cell/Tissue Type	Reference
Delayed-rectifier K ⁺ currents (Kv1.3)	Enhancement	Not specified	Larval tiger salamander retinal OFF-bipolar cells	[1]
Delayed rectifier K ⁺ current (IKrec)	Inhibition (at high [Ca _i])	Not specified	Cardiac muscle cells	[3]
Transient outward current (Ito)	Enhancement	Not specified	Cardiac muscle cells	[3]
ATP-sensitive K ⁺ current (IK(ATP))	Inhibition	Not specified	Cardiac muscle cells	[3]
5-HT-induced contractions	Inhibition	20, 40, 80 mM	Human radial artery	[4]
KCl-induced contractions	Inhibition	80 mM	Human radial artery	[4]
CaCl ₂ -induced contractions	Inhibition	20, 40, 80 mM	Human radial artery	[4]

1.2. Calcium and Sodium Channel Activity

Taurine's influence extends to other ion channels. In cardiac cells, it can inhibit the L-type Ca²⁺ current (ICa(L)) at high intracellular Ca²⁺ concentrations and enhance the T-type Ca²⁺ current (ICa(T)).[3] It has also been shown to inhibit the fast Na⁺ current (INa) while enhancing the TTX-insensitive slow Na⁺ current.[3]

Signaling Pathways

The biological effects of taurine are often mediated through the activation of intracellular signaling cascades.

2.1. PKC-Dependent Pathway in Retinal Neurons

In retinal neurons, the enhancement of Kv1.3 potassium channels by taurine is mediated through a G-protein linked, Protein Kinase C (PKC)-dependent pathway.[1][2] This metabotropic response is insensitive to classic GABA and glycine receptor antagonists but can be blocked by a specific antagonist of 5-HT_{2A} serotonin receptors, suggesting an interaction with the serotonin system.[2]



[Click to download full resolution via product page](#)

PKC-Dependent Pathway of Taurine in Retinal Neurons.

2.2. WNK-SPAK/OSR1 Pathway

In vitro studies have shown that taurine can inhibit the K⁺-Cl⁻ cotransporter KCC2 in embryonic neurons.[5] This inhibition is phosphorylation-dependent and is mediated by the activation of the With-no-lysine (WNK) protein kinase signaling pathway, specifically involving WNK1 and the downstream kinases SPAK and OSR1.[5]

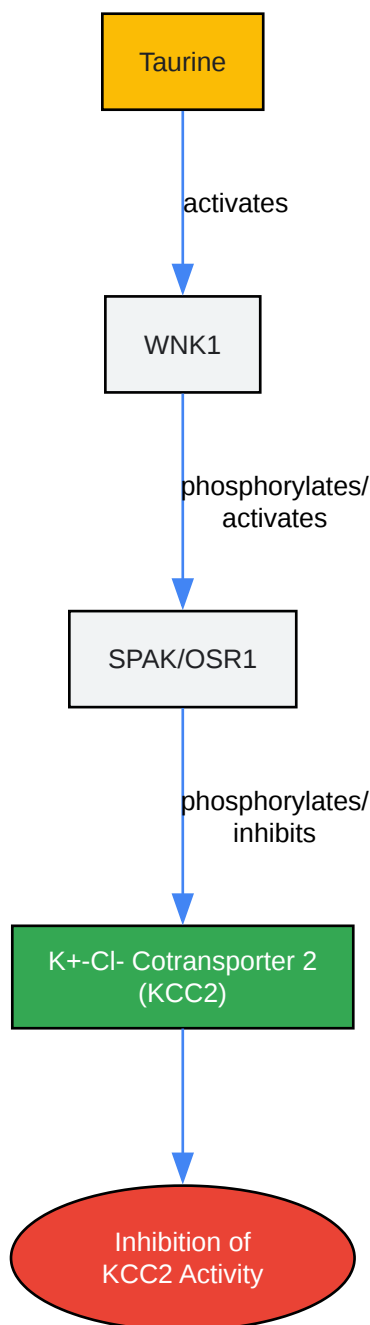

[Click to download full resolution via product page](#)

WNK-SPAK/OSR1 Pathway in Taurine-mediated KCC2 Inhibition.

2.3. ERK/Ets-1 Signaling Pathway

Taurine has been found to upregulate the expression of thioredoxin-interacting protein (TXNIP). This is achieved through the activation of the ERK signaling cascade, which leads to the

phosphorylation and activation of the transcription factor Ets-1.[6] Activated Ets-1 then binds to the TXNIP promoter, enhancing its transcriptional activity.[6]

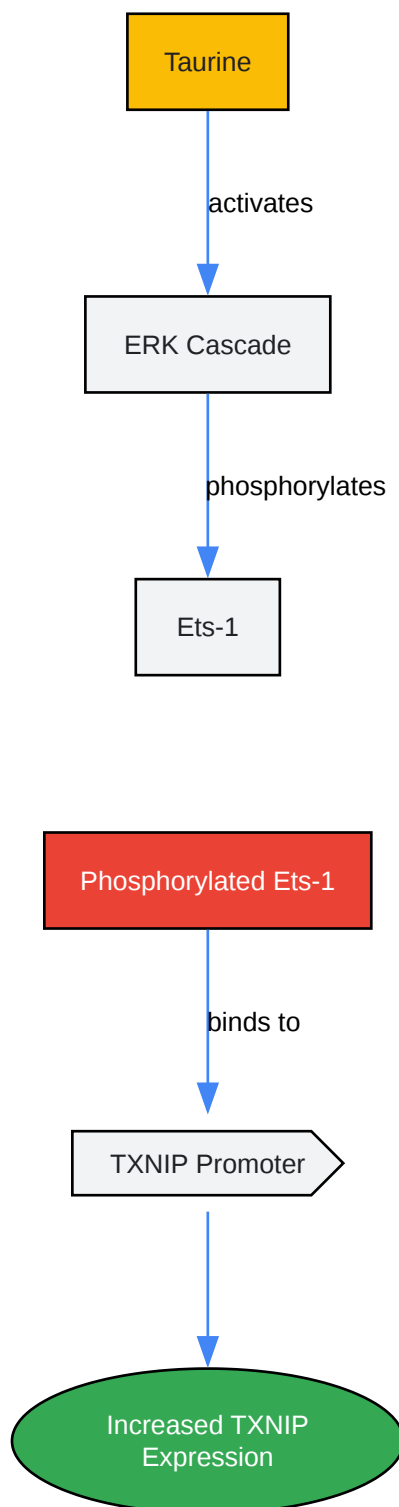

[Click to download full resolution via product page](#)

ERK/Ets-1 Pathway in Taurine-induced TXNIP Expression.

Antioxidant and Anti-inflammatory Activity

3.1. Antioxidant Effects

Taurine demonstrates significant antioxidant properties in vitro. It has been shown to protect human erythrocytes from oxidative damage induced by potassium bromate (KBrO₃) and hexavalent chromium [Cr(VI)].^{[7][8]} The protective mechanism involves scavenging reactive oxygen and nitrogen species, mitigating lipid and protein oxidation, and preserving the levels of endogenous antioxidants like glutathione.^{[7][8]} Taurine's antioxidant activity is also linked to its ability to regulate mitochondrial protein synthesis, which enhances the efficiency of the electron transport chain and reduces the generation of superoxide.^[9]

Quantitative Data on Antioxidant Activity

Assay	Effect	Model System	Toxin	Reference
Reactive Oxygen/Nitrogen Species	Concentration-dependent decrease	Human Erythrocytes	K ₂ Cr ₂ O ₇	[8]
Lipid Peroxidation	Decrease	Human Erythrocytes	KBrO ₃	[7]
Protein Oxidation	Decrease	Human Erythrocytes	KBrO ₃	[7]
Total Sulfhydryl Content	Preservation	Human Erythrocytes	KBrO ₃	[7]
Mitochondrial Superoxide Generation	Prevention	Isolated Cardiomyocytes	β-alanine induced	[9]

3.2. Anti-inflammatory Effects

Under inflammatory conditions, taurine is converted to taurine chloramine (TauCl) and taurine bromamine by phagocytes.^[10] TauCl, in particular, exhibits potent anti-inflammatory effects by

inhibiting the production of inflammatory mediators such as nitric oxide, tumor necrosis factor- α (TNF- α), and various interleukins in inflammatory cells.[10] It also upregulates the expression of several antioxidant proteins, thereby helping to resolve inflammation and protect tissues from oxidative damage.[10]

Experimental Protocols

4.1. Whole-Cell Patch Clamp Recordings

This technique is used to study the effects of taurine on ion channels in individual cells.

- Objective: To measure ion currents across the cell membrane in response to taurine application.
 - General Protocol:
 - Cell Preparation: Isolate retinal neurons or cardiac myocytes and place them in a recording chamber on an inverted microscope.
 - Pipette Preparation: Fabricate glass micropipettes and fill them with an intracellular solution (e.g., containing 130 mM potassium methanesulfonic acid, 10 mM KCl, 2 mM MgCl₂, 0.1 mM EGTA, and 10 mM HEPES, pH adjusted to 7.3 with KOH).[5]
 - Seal Formation: A high-resistance "giga-seal" is formed between the micropipette tip and the cell membrane.
 - Whole-Cell Configuration: Apply gentle suction to rupture the patch of membrane under the pipette, allowing electrical access to the cell's interior.
 - Recording: Apply voltage clamp protocols to hold the cell at a specific membrane potential and record the currents that flow in response to depolarization steps or drug application.
 - Drug Application: Taurine is applied to the cell via the extracellular bath solution. To isolate specific currents, an "inhibitory cocktail" may be used, containing blockers for other channels (e.g., TTX for sodium channels, picrotoxin and strychnine for Cl⁻ channels).[1]
- [11]

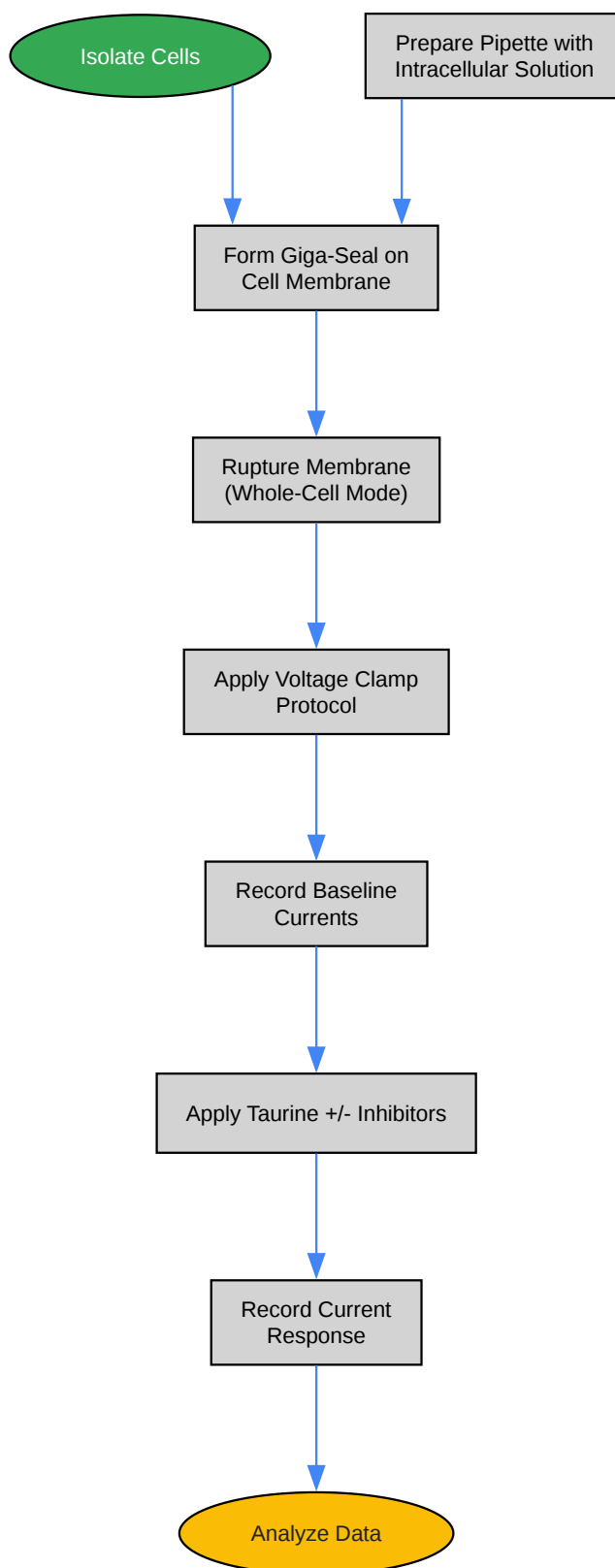

[Click to download full resolution via product page](#)

Workflow for Whole-Cell Patch Clamp Experiments.

4.2. In Vitro Erythrocyte Hemolysis and Oxidative Stress Assay

- Objective: To assess the protective effect of taurine against chemically-induced oxidative damage in red blood cells.
- General Protocol:
 - Blood Collection: Obtain blood from healthy volunteers and isolate erythrocytes by centrifugation.
 - Incubation: Incubate the isolated erythrocytes with varying concentrations of taurine.
 - Toxin Exposure: Add an oxidizing agent like potassium bromate (KBrO₃) to the erythrocyte suspension and incubate at 37°C for a specified time (e.g., 60 minutes).[7]
 - Hemolysis Measurement: Centrifuge the samples and measure the absorbance of the supernatant at a specific wavelength to quantify hemoglobin release (hemolysis).
 - Lysate Preparation: Prepare lysates from the remaining erythrocytes.
 - Biochemical Assays: Use the lysates to perform assays for markers of oxidative stress, such as lipid peroxidation (e.g., TBARS assay), protein carbonyl content, and levels of antioxidants like reduced glutathione (GSH).

Disclaimer: The information provided in this document is intended for research and informational purposes only. The biological activities described are primarily attributed to taurine, the active component of **potassium taurate** in biological systems. Further research is needed to elucidate any specific roles of the potassium counter-ion in these activities.

Need Custom Synthesis?

BenchChem offers custom synthesis for rare earth carbides and specific isotopic labeling.

Email: info@benchchem.com or [Request Quote Online](#).

References

- [1. iovs.arvojournals.org \[iovs.arvojournals.org\]](https://iovs.arvojournals.org)

- 2. Taurine activates delayed rectifier KV channels via a metabotropic pathway in retinal neurons - PMC [[pmc.ncbi.nlm.nih.gov](https://pubmed.ncbi.nlm.nih.gov)]
- 3. Cardiac actions of taurine as a modulator of the ion channels - PubMed [pubmed.ncbi.nlm.nih.gov]
- 4. KoreaMed Synapse [synapse.koreamed.org]
- 5. Taurine Inhibits K⁺-Cl⁻ Cotransporter KCC2 to Regulate Embryonic Cl⁻ Homeostasis via With-no-lysine (WNK) Protein Kinase Signaling Pathway - PMC [[pmc.ncbi.nlm.nih.gov](https://pubmed.ncbi.nlm.nih.gov)]
- 6. mdpi.com [mdpi.com]
- 7. researchgate.net [researchgate.net]
- 8. Taurine attenuates Cr(VI)-induced cellular and DNA damage: an in vitro study using human erythrocytes and lymphocytes - PubMed [pubmed.ncbi.nlm.nih.gov]
- 9. Mechanism underlying the antioxidant activity of taurine: prevention of mitochondrial oxidant production - PubMed [pubmed.ncbi.nlm.nih.gov]
- 10. Taurine chloramine produced from taurine under inflammation provides anti-inflammatory and cytoprotective effects - PubMed [pubmed.ncbi.nlm.nih.gov]
- 11. TAURINE REGULATION OF VOLTAGE-GATED CHANNELS IN RETINAL NEURONS - PMC [[pmc.ncbi.nlm.nih.gov](https://pubmed.ncbi.nlm.nih.gov)]
- To cite this document: BenchChem. [In Vitro Biological Activity of Potassium Taurate: A Technical Guide]. BenchChem, [2026]. [Online PDF]. Available at: [<https://www.benchchem.com/product/b1261178/docs#in-vitro-biological-activity-of-potassium-taurate-a-technical-guide>]

Disclaimer & Data Validity:

The information provided in this document is for Research Use Only (RUO) and is strictly not intended for diagnostic or therapeutic procedures. While BenchChem strives to provide accurate protocols, we make no warranties, express or implied, regarding the fitness of this product for every specific experimental setup.

Technical Support: The protocols provided are for reference purposes. Unsure if this reagent suits your experiment?

Need Industrial/Bulk Grade? [Request Custom Synthesis Quote](#)

BenchChem

Our mission is to be the trusted global source of essential and advanced chemicals, empowering scientists and researchers to drive progress in science and industry.

Contact

Address: 3281 E Guasti Rd

Ontario, CA 91761, United States

Phone: (601) 213-4426

Email: info@benchchem.com

[Contact our Ph.D. Support Team for a compatibility check](#)