

The Enhanced Biological Activity of Multimeric YIGSR Peptides: A Technical Guide

Author: BenchChem Technical Support Team. **Date:** April 2026

Compound of Interest

Compound Name: *C(Yigsr)3-NH2*

CAS No.: 145194-33-8

Cat. No.: B126921

[Get Quote](#)

For Researchers, Scientists, and Drug Development Professionals

Abstract

The pentapeptide Tyr-Ile-Gly-Ser-Arg (YIGSR), derived from the B1 chain of the laminin protein, is a crucial mediator of cellular interactions with the extracellular matrix.^{[1][2]} It is known to influence cell adhesion, migration, and to inhibit tumor growth and metastasis.^{[1][3][4]} However, the therapeutic potential of the monomeric YIGSR peptide is often limited by its weak biological activity. This guide explores the synthesis, enhanced biological functions, and mechanisms of action of multimeric YIGSR peptides, which have been developed to overcome the limitations of the monomer. We provide a comprehensive overview of the quantitative data, experimental protocols, and signaling pathways associated with these promising compounds.

Synthesis and Structure of Multimeric YIGSR Peptides

To enhance the biological potency of the YIGSR sequence, multimeric versions have been synthesized using a multimeric antigen peptide (MAP) system.^{[1][3]} This approach utilizes a

branched lysine core to assemble multiple copies of the peptide sequence into a single, larger molecule. For example, tetrameric (Ac-Y4), octameric (Ac-Y8), and hexadecameric (Ac-Y16) versions of the acetylated YIGSR-Gly sequence have been created.[1][3]

The general structure involves the YIGSR-Gly sequence being attached to a multi-tiered lysine core, such as (Ac-YIGSRG)₁₆-Lys₈-Lys₄-Lys₂-Lys-Gly for the Ac-Y16 variant.[3] This method offers a straightforward synthetic process and precise control over the final molecular size.[1]

Enhanced Biological Activity: Quantitative Data

Multimerization has been shown to dramatically enhance the anti-tumor and anti-metastatic activities of the YIGSR peptide. The larger the multimeric peptide, the greater its inhibitory effect.[1][3]

Table 1: Inhibition of Experimental Lung Metastasis by Multimeric YIGSR Peptides

Peptide Variant	Dose (per mouse)	Inhibition of Lung Colony Formation (%)	Source(s)
Ac-Y1 (Monomer)	0.2 mg	50%	[1][3]
Ac-Y4 (Tetramer)	0.2 mg	>50% (activity is dose-dependent)	[1][3]
Ac-Y8 (Octamer)	0.2 mg	>Ac-Y4 activity	[1][3]
Ac-Y16 (Hexadecamer)	0.2 mg	97%	[1][3]

Data derived from studies using B16-F10 mouse melanoma cells co-injected intravenously with the specified peptide.[1][3]

Table 2: Suppression of Subcutaneous Tumor Growth by Ac-Y16

Treatment Group	Dose (per mouse)	Effect on Tumor Weight	Source(s)
Ac-Y16	0.5 mg	Significant suppression	[4]
Ac-Y16	1.0 mg	Significant suppression	[4]
Ac-Y16	1.5 - 2.0 mg	Significant suppression	[4]

Data from a study where NALM6 human pre-B acute lymphoblastic leukaemia cells were co-injected subcutaneously with Matrigel and Ac-Y16 in SCID mice.[4]

Mechanism of Action and Signaling Pathways

The YIGSR peptide exerts its effects by interacting with specific cell surface receptors. The primary receptor identified is the 67 kDa high-affinity laminin receptor (67LR).[2][5][6] Additionally, interactions with integrins, including $\alpha4\beta1$, $\alpha6\beta1$, and other $\beta1$ -class integrins, have been reported to mediate its cell-adhesive activities.[7][8][9][10]

Binding of multimeric YIGSR to these receptors initiates a cascade of intracellular events that modulate cell behavior. This includes impacts on cell adhesion, migration, proliferation, and the inhibition of angiogenesis.[1] In some contexts, the YIGSR sequence can activate the integrin $\beta1$ /GSK3 β / β -catenin signaling pathway, which is crucial for neuronal differentiation.[11] In cardiac myocytes, YIGSR has been shown to affect the expression of Focal Adhesion Kinase (FAK).[12]

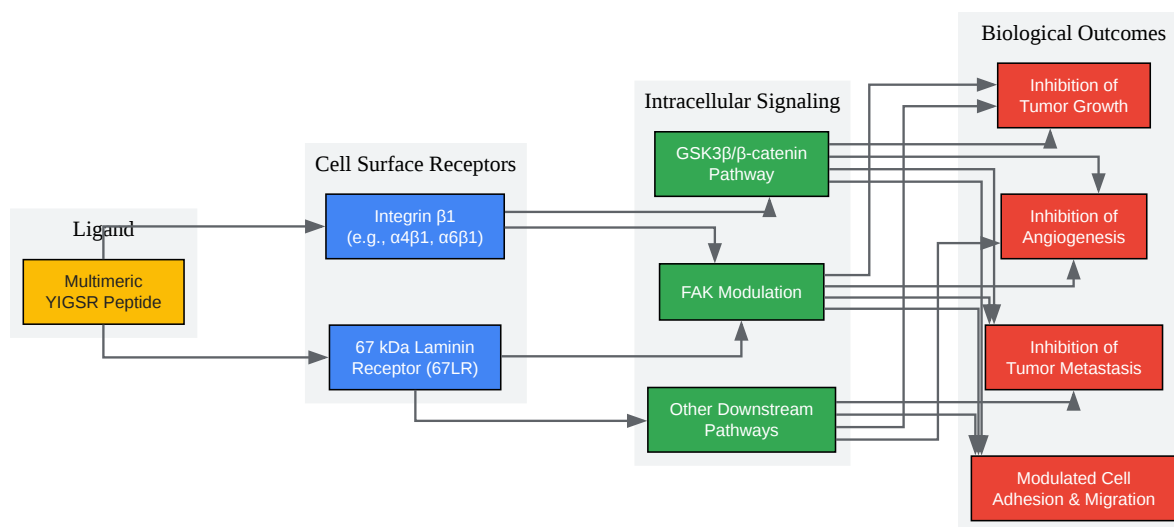

[Click to download full resolution via product page](#)

Caption: YIGSR peptide signaling cascade.

Experimental Protocols

In Vivo Anti-Metastasis Assay

This protocol is designed to evaluate the ability of multimeric YIGSR peptides to inhibit the formation of tumor colonies in a living model.

- **Cell Preparation:** Culture B16-F10 mouse melanoma cells under standard conditions. Harvest the cells using trypsin-EDTA, wash with serum-free medium, and resuspend in saline to a final concentration of approximately 2.5×10^5 cells/mL.
- **Peptide Preparation:** Dissolve the multimeric YIGSR peptide (e.g., Ac-Y16) and control peptides in sterile saline to the desired concentration (e.g., 1 mg/mL for a 0.2 mg dose in 0.2 mL).

- **Injection:** Mix the cell suspension with an equal volume of the peptide solution. Co-inject 0.4 mL of the final mixture (containing $\sim 5 \times 10^4$ cells and the peptide dose) into the lateral tail vein of C57BL/6 mice.
- **Incubation Period:** House the mice for a period of 14-21 days, providing standard care and monitoring for any adverse effects.
- **Analysis:** Euthanize the mice and excise the lungs. Fix the lungs in a suitable fixative (e.g., Bouin's solution). Count the number of black metastatic tumor colonies visible on the lung surface under a dissecting microscope.
- **Quantification:** Calculate the percentage of inhibition by comparing the average number of colonies in the peptide-treated group to the saline-treated control group.

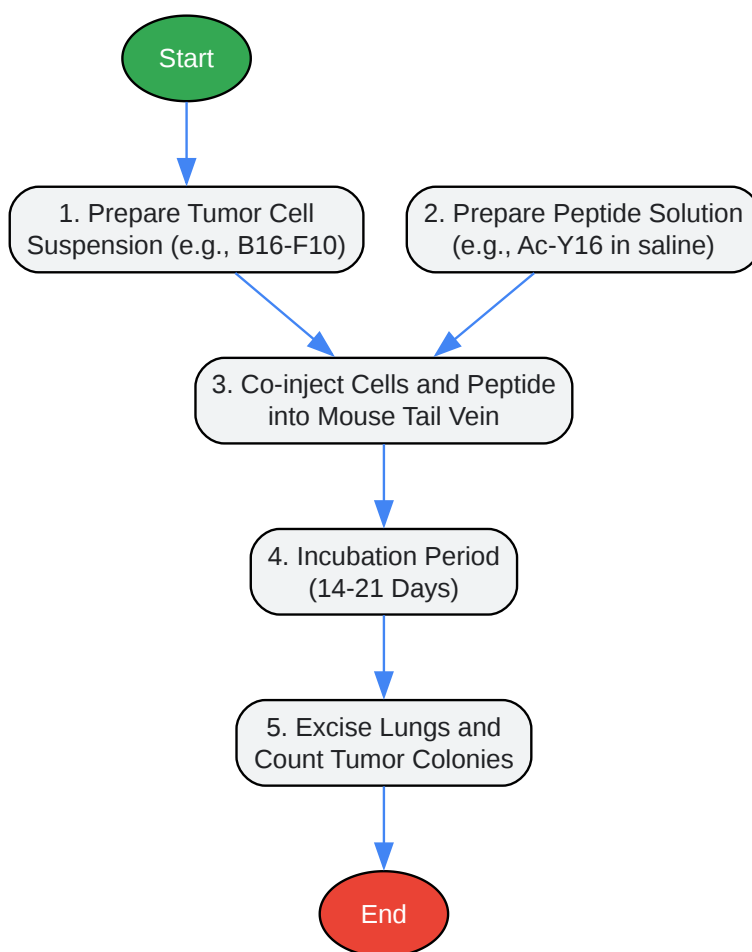

[Click to download full resolution via product page](#)

Caption: Workflow for an in vivo anti-metastasis assay.

Cell Adhesion Assay

- **Plate Coating:** Coat 96-well microtiter plates with the desired concentration of YIGSR peptide (monomeric or multimeric) in a suitable buffer (e.g., PBS) overnight at 4°C. Control wells should be coated with a non-adhesive protein like bovine serum albumin (BSA).
- **Blocking:** Wash the plates with PBS and block any remaining non-specific binding sites with a BSA solution for 1-2 hours at 37°C.
- **Cell Seeding:** Harvest cells (e.g., melanoma or endothelial cells), wash, and resuspend in serum-free medium. Add a defined number of cells (e.g., 1×10^4) to each well.
- **Incubation:** Incubate the plate for 1-2 hours at 37°C to allow for cell attachment.
- **Washing:** Gently wash the wells with PBS to remove non-adherent cells.
- **Quantification:** Fix the remaining adherent cells with methanol or glutaraldehyde and stain with a dye such as crystal violet. Solubilize the dye and measure the absorbance at a specific wavelength (e.g., 570 nm) using a plate reader. The absorbance is directly proportional to the number of adherent cells.

Cell Migration (Boyden Chamber) Assay

- **Chamber Setup:** Use a transwell insert (Boyden chamber) with a porous membrane (e.g., 8 μm pores). Coat the underside of the membrane with an extracellular matrix protein if studying haptotaxis.
- **Chemoattractant:** Place serum-free medium containing a chemoattractant (e.g., growth factors) or the YIGSR peptide in the lower chamber.
- **Cell Seeding:** Place a suspension of cells in serum-free medium into the upper chamber of the transwell insert.
- **Incubation:** Incubate for a period sufficient to allow cell migration (e.g., 4-24 hours) at 37°C.

- Analysis: Remove the insert and wipe away the non-migratory cells from the upper surface of the membrane with a cotton swab.
- Quantification: Fix and stain the migratory cells that have moved to the lower surface of the membrane. Count the cells in several microscopic fields to determine the average number of migrated cells.

Receptor Binding Assay

- Preparation: Prepare cell membrane fractions from a cell line known to express the YIGSR receptors or use purified receptor preparations.
- Radioligand: Use a radioactively labeled version of the YIGSR peptide or a known ligand for the receptor of interest.
- Competition Assay: In a multiwell filter plate, incubate a fixed amount of the receptor preparation and a fixed concentration of the radioligand with increasing concentrations of the unlabeled multimeric YIGSR peptide (the competitor).^{[13][14]}
- Incubation & Separation: Allow the binding to reach equilibrium. Rapidly filter the mixture through the filter plate to separate the receptor-bound radioligand from the free radioligand. Wash the filters to remove unbound radioactivity.
- Detection: Measure the radioactivity retained on the filter using a scintillation counter.
- Analysis: Plot the percentage of radioligand binding against the concentration of the unlabeled competitor peptide. Use non-linear regression to calculate the IC₅₀ value, which represents the concentration of the multimeric peptide required to inhibit 50% of the specific binding of the radioligand.

Structure-Activity Relationship

The data clearly demonstrates a direct correlation between the degree of multimerization and the biological activity of YIGSR peptides. The enhanced efficacy of larger multimers like Ac-Y16 is likely due to an avidity effect, where the multiple binding sites on a single molecule lead to a significantly stronger overall interaction with the cell surface receptors compared to the

monovalent binding of a single peptide. This increased binding affinity and receptor clustering likely triggers a more robust and sustained downstream signaling response.

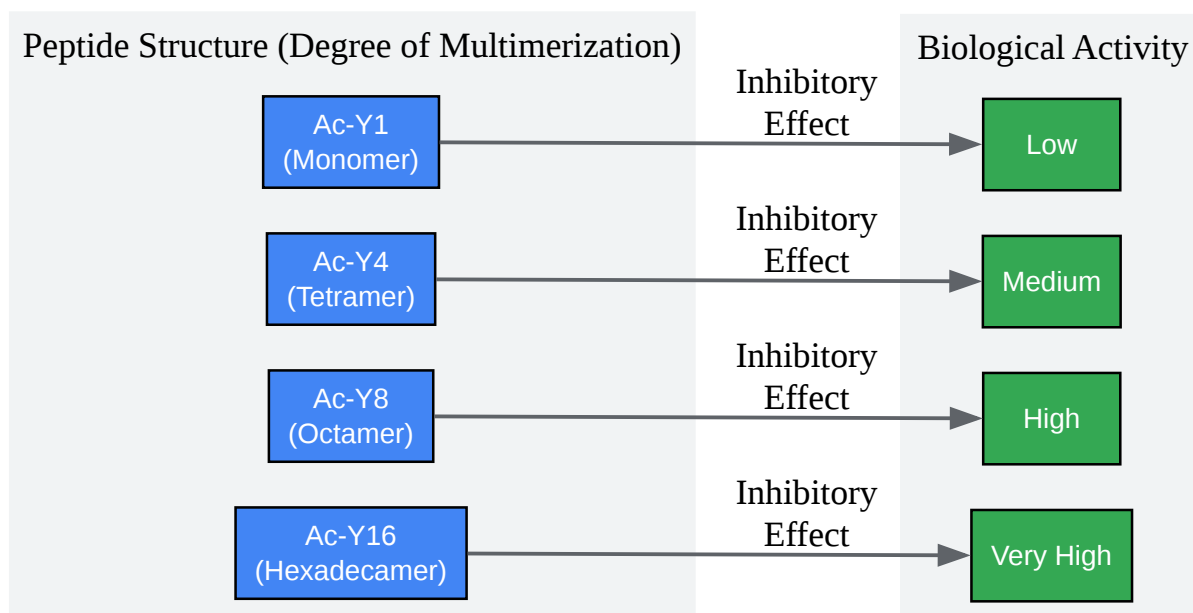

[Click to download full resolution via product page](#)

Caption: Multimerization enhances biological activity.

Conclusion and Future Directions

Multimeric YIGSR peptides demonstrate significantly enhanced anti-tumor and anti-metastatic properties compared to their monomeric counterpart.[1][3][15] The multimerization strategy effectively increases the avidity of the peptide for its cellular receptors, leading to more potent biological responses. These findings suggest that multimeric YIGSR compounds are promising candidates for therapeutic applications, potentially as standalone agents or as targeting moieties for drug delivery systems to tumors expressing the 67LR or specific integrins.[1][16]

Further research should focus on optimizing the pharmacokinetics of these larger peptides and exploring their efficacy in a broader range of cancer models.

Need Custom Synthesis?

BenchChem offers custom synthesis for rare earth carbides and specific isotopic labeling.

Email: info@benchchem.com or [Request Quote Online](#).

References

- [1. scispace.com \[scispace.com\]](https://www.scispace.com)
- [2. sigmaaldrich.com \[sigmaaldrich.com\]](https://www.sigmaaldrich.com)
- [3. Multimeric forms of Tyr-Ile-Gly-Ser-Arg \(YIGSR\) peptide enhance the inhibition of tumor growth and metastasis - PubMed \[pubmed.ncbi.nlm.nih.gov\]](#)
- [4. The laminin-derived peptide YIGSR \(Tyr-Ile-Gly-Ser-Arg\) inhibits human pre-B leukaemic cell growth and dissemination to organs in SCID mice - PMC \[pmc.ncbi.nlm.nih.gov\]](#)
- [5. medchemexpress.com \[medchemexpress.com\]](https://www.medchemexpress.com)
- [6. Treatment with YIGSR peptide ameliorates mouse tail lymphedema by 67 kDa laminin receptor \(67LR\)-dependent cell-cell adhesion - PMC \[pmc.ncbi.nlm.nih.gov\]](#)
- [7. Cell-adhesive activity and receptor-binding specificity of the laminin-derived YIGSR sequence grafted onto Staphylococcal protein A - PubMed \[pubmed.ncbi.nlm.nih.gov\]](#)
- [8. jstage.jst.go.jp \[jstage.jst.go.jp\]](https://www.jstage.jst.go.jp)
- [9. Enhancing Schwann Cell Migration Using Concentration Gradients of Laminin Derived-peptides - PMC \[pmc.ncbi.nlm.nih.gov\]](#)
- [10. YIGSR, A Laminin-Derived Peptide, Dictates a Concentration-Dependent Impact on Macrophage Phenotype Response - PMC \[pmc.ncbi.nlm.nih.gov\]](#)
- [11. A functionalized self-assembling peptide containing E7 and YIGSR sequences enhances neuronal differentiation of spermatogonial stem cells on aligned PCL fibers for spinal cord injury repair - PMC \[pmc.ncbi.nlm.nih.gov\]](#)
- [12. RGD and YIGSR synthetic peptides facilitate cellular adhesion identical to that of laminin and fibronectin but alter the physiology of neonatal cardiac myocytes - PubMed \[pubmed.ncbi.nlm.nih.gov\]](#)

- [13. Receptor Binding Assays - Multiwell Plates \[merckmillipore.com\]](#)
- [14. Receptor-Ligand Binding Assays \[labome.com\]](#)
- [15. Multimeric forms of Tyr-Ile-Gly-Ser-Arg \(YIGSR\) peptide enhance the inhibition of tumor growth and metastasis. | Semantic Scholar \[semanticscholar.org\]](#)
- [16. Laminin-111-derived peptides and cancer - PMC \[pmc.ncbi.nlm.nih.gov\]](#)
- To cite this document: BenchChem. [The Enhanced Biological Activity of Multimeric YIGSR Peptides: A Technical Guide]. BenchChem, [2026]. [Online PDF]. Available at: [\[https://www.benchchem.com/product/b126921/docs#the-enhanced-biological-activity-of-multimeric-yigsr-peptides-a-technical-guide\]](https://www.benchchem.com/product/b126921/docs#the-enhanced-biological-activity-of-multimeric-yigsr-peptides-a-technical-guide)

Disclaimer & Data Validity:

The information provided in this document is for Research Use Only (RUO) and is strictly not intended for diagnostic or therapeutic procedures. While BenchChem strives to provide accurate protocols, we make no warranties, express or implied, regarding the fitness of this product for every specific experimental setup.

Technical Support: The protocols provided are for reference purposes. Unsure if this reagent suits your experiment?

Need Industrial/Bulk Grade? [Request Custom Synthesis Quote](#)

BenchChem

Our mission is to be the trusted global source of essential and advanced chemicals, empowering scientists and researchers to drive progress in science and industry.

Contact

Address: 3281 E Guasti Rd

Ontario, CA 91761, United States

Phone: (601) 213-4426

Email: info@benchchem.com

Contact our Ph.D. Support Team for a compatibility check