

# Hexylcaine Hydrochloride: An In-depth Technical Guide for Ion Channel Research

**Author:** BenchChem Technical Support Team. **Date:** May 2026

## Compound of Interest

Compound Name: *Hexylcaine hydrochloride*

CAS No.: 532-76-3

Cat. No.: B126873

[Get Quote](#)

## Introduction: The Enduring Utility of Classic Probes in Modern Ion Channel Discovery

In the intricate landscape of ion channel research, the quest for selective and potent chemical probes is perpetual. While novel molecules continually emerge, a deep understanding of classic compounds remains fundamental. **Hexylcaine hydrochloride**, a short-acting local anesthetic, represents one such tool.<sup>[1][2]</sup> Though its clinical use has waned in some regions, its well-defined primary mechanism of action—blockade of voltage-gated sodium channels—renders it a valuable reference compound for dissecting the complexities of ion channel function and pharmacology.<sup>[3][4]</sup>

This guide provides a comprehensive technical overview of **hexylcaine hydrochloride** for researchers, scientists, and drug development professionals. Moving beyond a simple recitation of facts, we delve into the causal relationships behind experimental design, offer field-proven insights for its application, and provide a framework for its use as a chemical probe in the study of ion channels. We will explore its primary target, voltage-gated sodium channels, and discuss its potential off-target effects on other ion channel families and signaling pathways, providing a nuanced perspective for the modern researcher.

## Physicochemical Properties and Handling

A thorough understanding of a chemical probe's physical and chemical characteristics is paramount for reproducible and accurate experimental outcomes.

| Property          | Value  | Source    |
|-------------------|--|-----------|
| CAS Number        | 532-76-3   | [5][6][7] |
| Molecular Formula | C <sub>16</sub> H <sub>23</sub> NO <sub>2</sub> ·HCl | [5][7]    |
| Molecular Weight  | 297.82 g/mol   | [5][7]    |
| Melting Point     | 178 °C   | [5][7]    |
| Appearance        | White to off-white crystalline powder                | [8]       |
| Solubility        | Soluble in water                                     | [8]       |

### Stock Solution Preparation and Storage:

For in vitro electrophysiology experiments, a stock solution of **hexylcaine hydrochloride** is typically prepared in high-purity water. Given its aqueous solubility, concentrations of 10-100 mM are readily achievable.[8] It is recommended to filter-sterilize the stock solution through a 0.22 µm filter before storing it in aliquots at -20°C to prevent repeated freeze-thaw cycles. For working solutions, the stock is diluted to the final desired concentration in the appropriate extracellular or intracellular recording solution on the day of the experiment. A 1% solution of **hexylcaine hydrochloride** has been noted to be stable to boiling and autoclaving for sterilization purposes.[9]

### Safety and Handling:

**Hexylcaine hydrochloride** is harmful if swallowed and may cause irritation to the skin, eyes, and respiratory tract.[10][11][12] Standard laboratory personal protective equipment, including safety glasses, gloves, and a lab coat, should be worn during handling.[1][10][12] Work in a well-ventilated area to avoid inhalation of the powder.[1][10][12] In case of accidental contact, flush the affected area with copious amounts of water.[10][12]

## Primary Mechanism of Action: State-Dependent Blockade of Voltage-Gated Sodium Channels

The principal mechanism of action for **hexylcaine hydrochloride**, like other local anesthetics, is the inhibition of voltage-gated sodium channels (NaV channels).[3][4] These channels are critical for the initiation and propagation of action potentials in excitable cells, including neurons. By blocking the influx of sodium ions, hexylcaine effectively dampens neuronal excitability, leading to its anesthetic effect.[3][13]

The interaction of local anesthetics with NaV channels is not static; it is highly dependent on the conformational state of the channel. This phenomenon, known as state-dependent blockade, is a cornerstone of their mechanism and a critical consideration for experimental design.[13] NaV channels cycle through three primary states:

- **Resting State:** At hyperpolarized membrane potentials, the channel is closed and capable of opening in response to depolarization.
- **Open/Activated State:** Upon membrane depolarization, the channel opens, allowing for the rapid influx of Na<sup>+</sup> ions.
- **Inactivated State:** Following a brief opening, the channel enters a non-conductive, inactivated state from which it must return to the resting state before it can be opened again.

Local anesthetics, including hexylcaine, generally exhibit a higher affinity for the open and inactivated states of the NaV channel compared to the resting state.[13] This preferential binding explains the use-dependent or phasic block, where the degree of inhibition increases with the frequency of channel activation (i.e., with more frequent action potentials).[13]

Caption: State-dependent binding of hexylcaine to voltage-gated sodium channels.

## Comparative Pharmacology with Other Local Anesthetics

While specific quantitative data for hexylcaine across various ion channel subtypes is sparse in modern literature, a comparative understanding can be gleaned from the extensive research on other local anesthetics, such as lidocaine.

| Local Anesthetic | Primary Target | Potency on NaV Channels                     | Potency on KV Channels        | Potency on CaV Channels                         |
|------------------|----------------|---|-------------------------------|---|
| Hexylcaine       | NaV Channels   | Data not readily available                  | Lower than NaV channels       | Lower than NaV channels                         |
| Lidocaine        | NaV Channels   | IC <sub>50</sub> ~200-500 $\mu$ M (resting) | IC <sub>50</sub> ~1-2 mM      | Inhibition at high $\mu$ M to mM concentrations |
| Bupivacaine      | NaV Channels   | IC <sub>50</sub> ~30 $\mu$ M (resting)      | IC <sub>50</sub> ~90 $\mu$ M  | Inhibition at $\mu$ M concentrations            |
| Tetracaine       | NaV Channels   | IC <sub>50</sub> ~1 $\mu$ M (resting)       | IC <sub>50</sub> ~950 $\mu$ M | Potent inhibition                               |

Note: IC<sub>50</sub> values are approximate and can vary significantly based on the specific ion channel subtype, its state, and the experimental conditions. Data for lidocaine, bupivacaine, and tetracaine are provided for comparative context.

Generally, the potency of local anesthetics on NaV channels correlates with their lipid solubility and protein binding capacity.<sup>[13]</sup> The lower potency on potassium and calcium channels suggests that at concentrations effective for NaV channel blockade, the effects on these other channels may be less pronounced but should not be disregarded, especially at higher concentrations.<sup>[14][15]</sup>

## Experimental Protocols for Ion Channel Characterization

The gold-standard technique for studying the effects of compounds like hexylcaine on ion channels is patch-clamp electrophysiology. This method allows for the direct measurement of ion flow through channels in real-time.

Objective: To determine the tonic and use-dependent block of a voltage-gated sodium channel subtype (e.g., NaV1.7) expressed in a heterologous system (e.g., HEK293 cells) by **hexylcaine hydrochloride**.

#### Materials:

- HEK293 cells stably expressing the target NaV channel subtype.
- **Hexylcaine hydrochloride** stock solution (100 mM in water).
- Extracellular (bath) solution (in mM): 140 NaCl, 5 KCl, 2 CaCl<sub>2</sub>, 1 MgCl<sub>2</sub>, 10 HEPES, 10 Glucose (pH adjusted to 7.4 with NaOH).
- Intracellular (pipette) solution (in mM): 140 CsF, 10 NaCl, 1 EGTA, 10 HEPES (pH adjusted to 7.2 with CsOH).
- Patch-clamp rig (amplifier, digitizer, microscope, micromanipulator).

#### Step-by-Step Methodology:

- Cell Preparation: Plate the cells on glass coverslips 24-48 hours before the experiment to achieve 50-70% confluency.
- Pipette Preparation: Pull borosilicate glass capillaries to a resistance of 2-5 MΩ when filled with the intracellular solution.
- Establish Whole-Cell Configuration:
  - Transfer a coverslip with cells to the recording chamber and perfuse with the extracellular solution.
  - Approach a single, healthy-looking cell with the patch pipette and apply gentle positive pressure.
  - Upon contacting the cell, release the positive pressure to form a gigaohm seal (>1 GΩ).
  - Apply gentle suction to rupture the cell membrane and achieve the whole-cell configuration.
- Tonic Block Protocol:

- Hold the cell at a hyperpolarized potential (e.g., -120 mV) where most channels are in the resting state.
- Apply a brief depolarizing pulse (e.g., to 0 mV for 20 ms) at a low frequency (e.g., 0.1 Hz) to elicit a baseline sodium current.
- Perfuse the cell with increasing concentrations of **hexylcaine hydrochloride** (e.g., 1  $\mu$ M to 1 mM) and record the steady-state reduction in the peak sodium current at each concentration.
- Use-Dependent Block Protocol:
  - Hold the cell at a hyperpolarized potential (e.g., -120 mV).
  - Apply a train of depolarizing pulses (e.g., to 0 mV for 20 ms) at a higher frequency (e.g., 10 Hz).
  - Measure the progressive decrease in the peak sodium current during the pulse train in the absence and presence of various concentrations of hexylcaine.
- Data Analysis:
  - For tonic block, plot the fractional block versus the hexylcaine concentration and fit the data with the Hill equation to determine the  $IC_{50}$ .
  - For use-dependent block, quantify the degree of block at each pulse in the train and compare it across different concentrations and frequencies.

Caption: A typical experimental workflow for characterizing hexylcaine's effects.

## Potential Off-Target Effects: A Consideration for Comprehensive Profiling

While the primary target of hexylcaine is the NaV channel, as a responsible scientist, it is crucial to consider potential off-target effects, especially when using it as a chemical probe.

Potassium (KV) and Calcium (CaV) Channels:

As mentioned, local anesthetics are known to block KV and CaV channels, albeit with lower potency than NaV channels.[14][15] This inhibition is generally more pronounced at higher concentrations. When designing experiments, it is advisable to perform concentration-response curves to determine the selectivity window for NaV channel blockade versus effects on other channels. If a study aims to isolate the effects of NaV channel blockade, using concentrations of hexylcaine at or below its IC<sub>50</sub> for NaV channels (if determined) is a good starting point to minimize off-target effects on KV and CaV channels.

#### Angiogenesis Signaling: VEGF and TGF-β:

Interestingly, some sources suggest that **hexylcaine hydrochloride** may inhibit angiogenesis by binding to angiogenic factors such as Vascular Endothelial Growth Factor A (VEGF-A) and Transforming Growth Factor-beta 1 (TGF-β1).[5][7] These signaling molecules are pivotal in the formation of new blood vessels.[16][17][18][19][20]

- VEGF Signaling: VEGF-A is a potent pro-angiogenic factor that binds to its receptor (VEGFR) on endothelial cells, triggering a signaling cascade that promotes cell proliferation, migration, and survival.
- TGF-β Signaling: TGF-β has a more complex, context-dependent role in angiogenesis. It can either promote or inhibit blood vessel formation depending on the cellular environment and the presence of other signaling molecules.

The claim of direct binding of hexylcaine to these growth factors requires further validation through dedicated binding assays (e.g., surface plasmon resonance) and functional angiogenesis assays (e.g., tube formation assays). Researchers should be aware of this potential off-target effect, particularly in studies involving cell growth, proliferation, or tissue-level responses where angiogenesis may play a role.

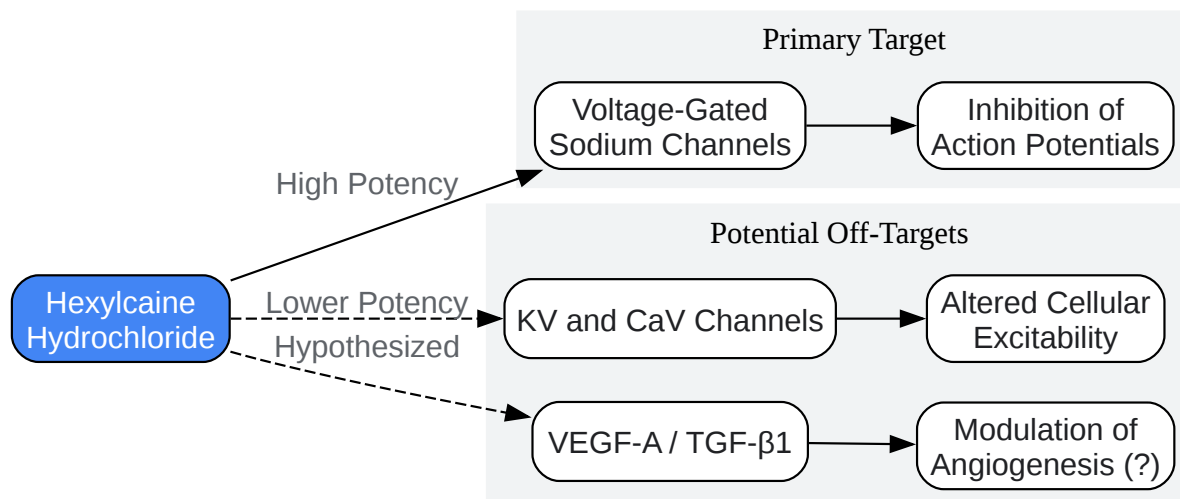

[Click to download full resolution via product page](#)

Caption: Primary and potential off-target effects of **hexylcaine hydrochloride**.

## Conclusion: A Classic Probe with Enduring Relevance

**Hexylcaine hydrochloride**, while a compound with a long history, continues to hold relevance as a chemical probe for the study of ion channels. Its primary action as a state- and use-dependent blocker of voltage-gated sodium channels is well-established within the broader class of local anesthetics. This guide has provided a framework for its application in research, emphasizing the importance of understanding its physicochemical properties, its primary mechanism of action, and its potential off-target effects.

The notable scarcity of modern, quantitative data on hexylcaine's interactions with specific ion channel subtypes presents both a challenge and an opportunity. For researchers, this highlights the need for careful characterization and validation in their specific experimental systems. It also underscores an area ripe for investigation—a thorough biophysical characterization of hexylcaine could provide valuable comparative data for the field of local anesthetic pharmacology. By applying the principles and protocols outlined in this guide,

researchers can effectively leverage **hexylcaine hydrochloride** as a tool to further unravel the intricate functions of ion channels.

## References

- Nau, C., & Strichartz, G. R. (2002). Mechanisms of (local) anaesthetics on voltage-gated sodium and other ion channels. *British Journal of Anaesthesia*, 89(1), 52–61. [[Link](#)]
- Šimurdová, M., & Šimurda, J. (1993). Comparison of effects of selected local anesthetics on sodium and potassium channels in mammalian neuron. *General Physiology and Biophysics*, 12(5), 437-448. [[Link](#)]
- Fan, P., & Bryant, S. H. (1998). Effects of local anesthetics on opioid inhibition of calcium current in rat dorsal root ganglion neurons. *Anesthesiology*, 88(6), 1646–1654. [[Link](#)]
- Fozzard, H. A., Sheets, M. F., & Hanck, D. A. (2011). The Sodium Channel as a Target for Local Anesthetic Drugs. *Frontiers in Pharmacology*, 2, 61. [[Link](#)]
- Becker, D. E., & Reed, K. L. (2012). Local Anesthetics: Review of Pharmacological Considerations. *Anesthesia Progress*, 59(2), 90–102. [[Link](#)]
- Henry Schein. (2019). SAFETY DATA SHEET: Lidocaine HCl Injection with Preservative. [[Link](#)]
- Wang, S., Al-Sabi, A., & Enkvetchakul, D. (2011). Interaction of local anesthetics with the K<sup>+</sup> channel pore domain: KcsA as a model for drug-dependent tetramer stability. *Channels*, 5(3), 223–230. [[Link](#)]
- British Pharmacopoeia. (2013). Safety data sheet: Lidocaine (Lignocaine) hydrochloride. [[Link](#)]
- The Merck Index Online. (n.d.). **Hexylcaine Hydrochloride**. Retrieved January 14, 2026, from [[Link](#)]
- Sugimoto, M., et al. (2003). Local Anesthetic Inhibition of Voltage-activated Potassium Currents in Rat Dorsal Root Ganglion Neurons. *Anesthesiology*, 98(6), 1439-1447. [[Link](#)]

- Vyklický, L. Jr., Vlachová, V., & Vyklický, L. (1993). Comparison of Effects of Selected Local Anesthetics on Sodium and Potassium Channels in Mammalian Neuron. *General Physiology and Biophysics*, 12(5), 437-448. [[Link](#)]
- Wikipedia. (2023). Hexylcaine. [[Link](#)]
- National Center for Biotechnology Information. (n.d.). PubChem Compound Summary for CID 10770, Hexylcaine. Retrieved January 14, 2026, from [[Link](#)]
- Wheat, J. D. (1952). The clinical use of cyclaine (**hexylcaine hydrochloride**) as a local anesthetic; a preliminary report. *Journal of the American Veterinary Medical Association*, 120(899), 71–72. [[Link](#)]
- Le, N., et al. (2017). Modulation of cerebral endothelial cell function by TGF- $\beta$  in glioblastoma: VEGF-dependent angiogenesis versus endothelial mesenchymal transition. *Oncotarget*, 8(46), 80563–80577. [[Link](#)]
- Lu-Yuan, L., et al. (2018). Counterbalance: modulation of VEGF/VEGFR activities by TNFSF15. *Cellular & Molecular Immunology*, 15(8), 736–744. [[Link](#)]
- Lee, K. S., et al. (2007). Inhibition of VEGF blocks TGF-beta1 production through a PI3K/Akt signalling pathway. *European Respiratory Journal*, 30(6), 1052–1061. [[Link](#)]
- Ferrari, G., et al. (2006). Transforming growth factor-beta 1 (TGF-beta1) induces angiogenesis through vascular endothelial growth factor (VEGF)-mediated apoptosis. *Journal of Cell Physiology*, 209(3), 841–848. [[Link](#)]
- Kim, H. R., et al. (2006). Mechanisms underlying TGF-beta1-induced expression of VEGF and Flk-1 in mouse macrophages and their implications for angiogenesis. *Journal of Immunology*, 177(8), 5573–5582. [[Link](#)]
- Orkin, L. R., & Rovenstine, E. A. (1952). Clinical use of cyclaine (**hexylcaine hydrochloride**) for spinal and regional nerve block: report of 2000 cases. *Anesthesiology*, 13(4), 429–434. [[Link](#)]

### Need Custom Synthesis?

BenchChem offers custom synthesis for rare earth carbides and specific isotopic labeling.

Email: [info@benchchem.com](mailto:info@benchchem.com) or [Request Quote Online](#).

## Sources

- [1. henryschein.ca \[henryschein.ca\]](https://henryschein.ca)
- [2. Hexylcaine - Wikipedia \[en.wikipedia.org\]](https://en.wikipedia.org)
- [3. Effects of local anesthetics on opioid inhibition of calcium current in rat dorsal root ganglion neurons - PMC \[pmc.ncbi.nlm.nih.gov\]](https://pubmed.ncbi.nlm.nih.gov)
- [4. Hexylcaine | C16H23NO2 | CID 10770 - PubChem \[pubchem.ncbi.nlm.nih.gov\]](https://pubchem.ncbi.nlm.nih.gov)
- [5. Interaction of local anesthetics with the K<sup>+</sup> channel pore domain: KcsA as a model for drug-dependent tetramer stability - PMC \[pmc.ncbi.nlm.nih.gov\]](https://pubmed.ncbi.nlm.nih.gov)
- [6. scbt.com \[scbt.com\]](https://scbt.com)
- [7. biosynth.com \[biosynth.com\]](https://biosynth.com)
- [8. CAS 532-76-3: Hexylcaine hydrochloride | CymitQuimica \[cymitquimica.com\]](https://cymitquimica.com)
- [9. Hexylcaine Hydrochloride \[drugfuture.com\]](https://drugfuture.com)
- [10. pccarx.com \[pccarx.com\]](https://pccarx.com)
- [11. pharmacopoeia.com \[pharmacopoeia.com\]](https://pharmacopoeia.com)
- [12. datasheets.scbt.com \[datasheets.scbt.com\]](https://datasheets.scbt.com)
- [13. Local Anesthetics: Review of Pharmacological Considerations - PMC \[pmc.ncbi.nlm.nih.gov\]](https://pubmed.ncbi.nlm.nih.gov)
- [14. academic.oup.com \[academic.oup.com\]](https://academic.oup.com)
- [15. Comparison of effects of selected local anesthetics on sodium and potassium channels in mammalian neuron - PubMed \[pubmed.ncbi.nlm.nih.gov\]](https://pubmed.ncbi.nlm.nih.gov)
- [16. Modulation of cerebral endothelial cell function by TGF- \$\beta\$  in glioblastoma: VEGF-dependent angiogenesis versus endothelial mesenchymal transition - PMC \[pmc.ncbi.nlm.nih.gov\]](https://pubmed.ncbi.nlm.nih.gov)
- [17. Counterbalance: modulation of VEGF/VEGFR activities by TNFSF15 - PMC \[pmc.ncbi.nlm.nih.gov\]](https://pubmed.ncbi.nlm.nih.gov)

- [18. Inhibition of VEGF blocks TGF-beta1 production through a PI3K/Akt signalling pathway - PubMed \[pubmed.ncbi.nlm.nih.gov\]](#)
- [19. Transforming growth factor-beta 1 \(TGF-beta1\) induces angiogenesis through vascular endothelial growth factor \(VEGF\)-mediated apoptosis - PubMed \[pubmed.ncbi.nlm.nih.gov\]](#)
- [20. Mechanisms underlying TGF-beta1-induced expression of VEGF and Flk-1 in mouse macrophages and their implications for angiogenesis - PubMed \[pubmed.ncbi.nlm.nih.gov\]](#)
- To cite this document: BenchChem. [Hexylcaine Hydrochloride: An In-depth Technical Guide for Ion Channel Research]. BenchChem, [2026]. [Online PDF]. Available at: [\[https://www.benchchem.com/product/b126873/docs#hexylcaine-hydrochloride-an-in-depth-technical-guide-for-ion-channel-research\]](https://www.benchchem.com/product/b126873/docs#hexylcaine-hydrochloride-an-in-depth-technical-guide-for-ion-channel-research)

---

### Disclaimer & Data Validity:

The information provided in this document is for Research Use Only (RUO) and is strictly not intended for diagnostic or therapeutic procedures. While BenchChem strives to provide accurate protocols, we make no warranties, express or implied, regarding the fitness of this product for every specific experimental setup.

**Technical Support:** The protocols provided are for reference purposes. Unsure if this reagent suits your experiment?

**Need Industrial/Bulk Grade?** [Request Custom Synthesis Quote](#)

## BenchChem

Our mission is to be the trusted global source of essential and advanced chemicals, empowering scientists and researchers to drive progress in science and industry.

### Contact

Address: 3281 E Guasti Rd

Ontario, CA 91761, United States

Phone: (601) 213-4426

Email: [info@benchchem.com](mailto:info@benchchem.com)

Contact our Ph.D. Support Team for a compatibility check