

Application Notes and Protocols for C(YIGSR)3-NH2 Dose-Response Studies

Author: BenchChem Technical Support Team. **Date:** April 2026

Compound of Interest

Compound Name: C(Yigsr)3-NH2

CAS No.: 145194-33-8

Cat. No.: B126921

[Get Quote](#)

For Researchers, Scientists, and Drug Development Professionals

Introduction

C(YIGSR)3-NH2 is a synthetic peptide containing the Tyrosine-Isoleucine-Glycine-Serine-Arginine (YIGSR) sequence, a functional motif derived from the β 1 chain of laminin.[1][2] This sequence is recognized by the 67-kDa laminin receptor (67LR), a non-integrin receptor overexpressed in various cancer cells.[3][4] The interaction of YIGSR with 67LR has been shown to inhibit tumor growth and metastasis.[1][2] In prostate cancer cells, for instance, the YIGSR peptide has been demonstrated to induce apoptosis by decreasing the mitochondrial membrane potential and increasing caspase 9 activity.[2] The biological effects of YIGSR-containing peptides are concentration-dependent, highlighting the importance of thorough dose-response studies to determine optimal concentrations for therapeutic efficacy.[5][6][7]

These application notes provide a comprehensive set of protocols for conducting in vitro dose-response studies with **C(YIGSR)3-NH2**, focusing on its effects on cell viability, proliferation, apoptosis, and key signaling pathways.

Experimental Design Overview

A typical dose-response study for **C(YIGSR)3-NH2** involves treating a relevant cancer cell line with a range of peptide concentrations. The selection of concentrations should be based on literature values for similar YIGSR peptides, which have shown biological activity in the micromolar (μM) to millimolar (mM) range.[5][8][9] The following experiments are recommended to comprehensively assess the cellular response to **C(YIGSR)3-NH2**.

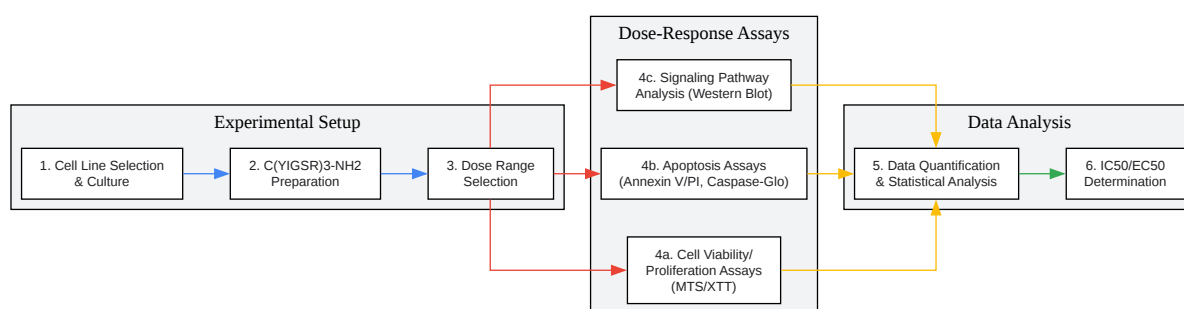

[Click to download full resolution via product page](#)

Figure 1: Experimental workflow for **C(Yigsr)3-NH2** dose-response studies.

Key Experimental Protocols

Cell Culture and Treatment

- **Cell Line Selection:** Choose a cancer cell line known to express the 67-kDa laminin receptor. Examples include prostate cancer cell lines (e.g., PC-3), breast cancer cell lines, or other relevant cancer models.
- **Cell Seeding:** Seed cells in appropriate multi-well plates (e.g., 96-well plates for viability and caspase assays, 6-well plates for Western blotting and flow cytometry) at a density that allows for logarithmic growth during the experiment.

- **C(YIGSR)3-NH2** Preparation: Dissolve **C(YIGSR)3-NH2** in a sterile, aqueous solvent such as water or phosphate-buffered saline (PBS).[2] Prepare a stock solution and make serial dilutions to achieve the desired final concentrations for treatment.
- Treatment: Replace the cell culture medium with a fresh medium containing the various concentrations of **C(YIGSR)3-NH2** or a vehicle control (the solvent used to dissolve the peptide). Incubate the cells for the desired time points (e.g., 24, 48, 72 hours).

Cell Viability and Proliferation Assays (MTS/XTT)

These colorimetric assays measure the metabolic activity of cells, which is proportional to the number of viable cells.

- Principle: Tetrazolium salts (MTS or XTT) are reduced by metabolically active cells to a colored formazan product.[10][11]
- Protocol:
 - After the treatment period, add the MTS or XTT reagent to each well according to the manufacturer's instructions.[10][12]
 - Incubate the plate for 1-4 hours at 37°C.[10][12]
 - Measure the absorbance at the appropriate wavelength (e.g., 490 nm for MTS/XTT) using a microplate reader.[11][12]
 - Calculate cell viability as a percentage of the vehicle-treated control.

Apoptosis Assays

This assay distinguishes between viable, early apoptotic, late apoptotic, and necrotic cells.

- Principle: In early apoptosis, phosphatidylserine (PS) translocates to the outer leaflet of the plasma membrane, where it can be detected by fluorescently labeled Annexin V.[13][14] Propidium iodide (PI) is a fluorescent nuclear stain that can only enter cells with compromised membranes, thus identifying late apoptotic and necrotic cells.[13][14]
- Protocol:

- Harvest cells after treatment, including any floating cells in the medium.
- Wash the cells with cold PBS.[15]
- Resuspend the cells in 1X Binding Buffer.[16]
- Add Annexin V-FITC and PI to the cell suspension according to the manufacturer's protocol.[15][16]
- Incubate for 15-20 minutes at room temperature in the dark.[16]
- Analyze the stained cells by flow cytometry.[14][15]

This luminescent assay measures the activity of caspases-3 and -7, key executioner caspases in the apoptotic pathway.

- Principle: The assay reagent contains a proluminescent caspase-3/7 substrate (containing the DEVD sequence).[17] Cleavage of this substrate by active caspases-3/7 releases a substrate for luciferase, generating a luminescent signal that is proportional to caspase activity.[17][18]
- Protocol:
 - After treatment, allow the multi-well plate to equilibrate to room temperature.[18]
 - Add the Caspase-Glo® 3/7 reagent to each well.[19]
 - Mix and incubate at room temperature for 30 minutes to 3 hours.[18]
 - Measure luminescence using a luminometer.[18]

Signaling Pathway Analysis by Western Blotting

Western blotting is used to detect changes in the expression and phosphorylation status of key proteins in signaling pathways downstream of the 67-kDa laminin receptor.

- Principle: Proteins from cell lysates are separated by size via gel electrophoresis, transferred to a membrane, and detected using specific antibodies.

- Protocol:
 - Cell Lysis: After treatment, wash cells with cold PBS and lyse them in a suitable lysis buffer containing protease and phosphatase inhibitors.
 - Protein Quantification: Determine the protein concentration of each lysate using a standard method (e.g., BCA assay).
 - SDS-PAGE and Transfer: Separate equal amounts of protein on an SDS-polyacrylamide gel and transfer the proteins to a PVDF or nitrocellulose membrane.
 - Immunoblotting:
 - Block the membrane to prevent non-specific antibody binding.
 - Incubate the membrane with primary antibodies against proteins of interest (e.g., phospho-FAK, FAK, phospho-ERK, ERK, phospho-Akt, Akt, and a loading control like β -actin or GAPDH). The YIGSR peptide has been shown to modulate FAK and MEK/ERK signaling.[\[20\]](#) The 67LR can also regulate MAPK/ERK and PI3K/Akt pathways.[\[21\]](#)
 - Wash the membrane and incubate with a horseradish peroxidase (HRP)-conjugated secondary antibody.
 - Detect the signal using an enhanced chemiluminescence (ECL) substrate.

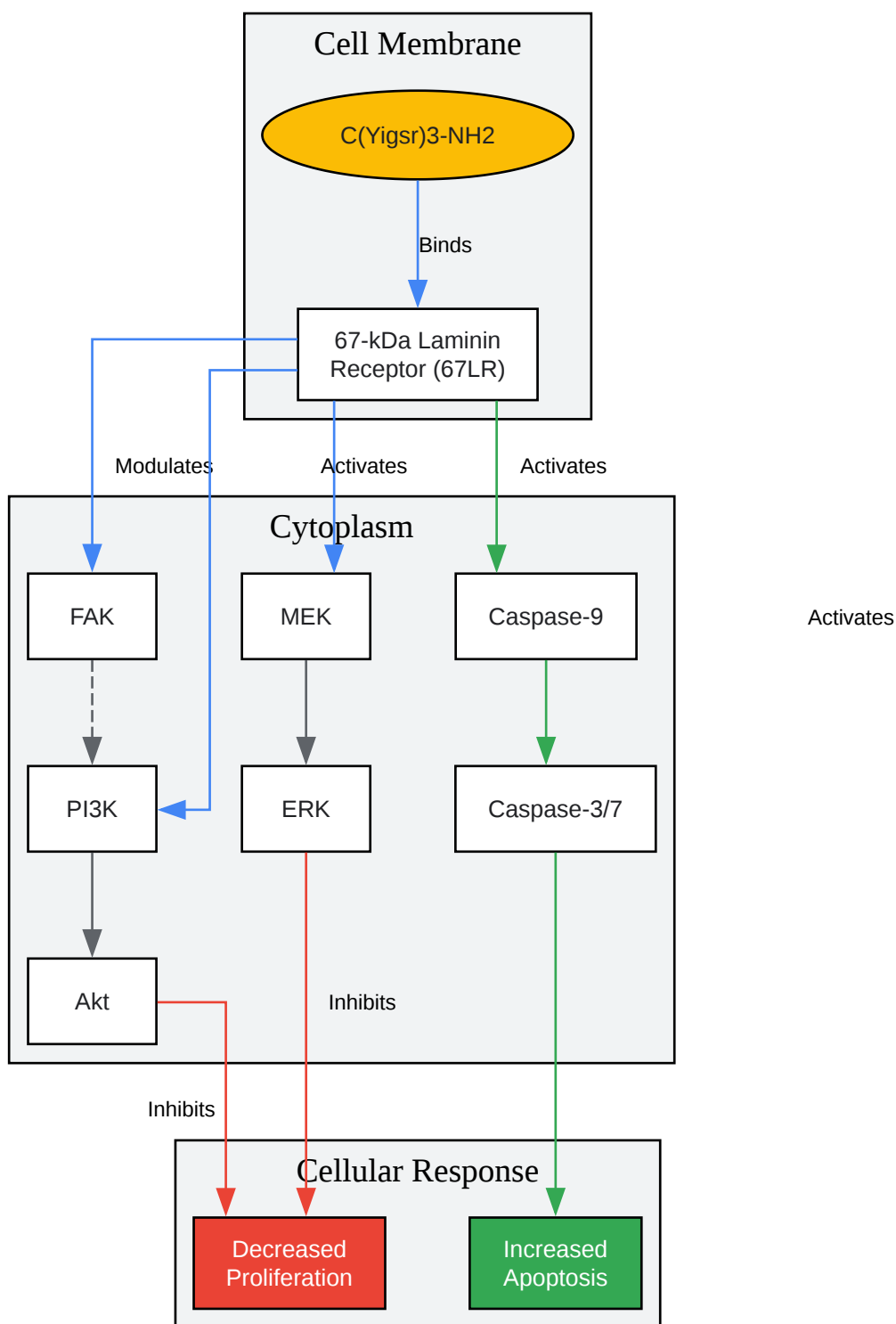

[Click to download full resolution via product page](#)

Figure 2: Potential signaling pathways modulated by C(Yigrs)3-NH2.

Data Presentation

Quantitative data from the dose-response studies should be summarized in tables for clear comparison.

Table 1: Effect of **C(YIGSR)3-NH2** on Cell Viability/Proliferation

C(YIGSR)3-NH2 Conc.	24h (% Viability ± SD)	48h (% Viability ± SD)	72h (% Viability ± SD)
Vehicle Control	100 ± 5.2	100 ± 6.1	100 ± 5.8
1 µM			
10 µM			
100 µM			
500 µM			
1 mM			
5 mM			

Table 2: Effect of **C(YIGSR)3-NH2** on Apoptosis (48h Treatment)

C(YIGSR)3-NH2 Conc.	Early Apoptotic Cells (%)	Late Apoptotic/Necrotic Cells (%)	Caspase-3/7 Activity (RLU)
Vehicle Control			
1 µM			
10 µM			
100 µM			
500 µM			
1 mM			
5 mM			

Table 3: Summary of Western Blot Analysis (48h Treatment)

C(YIGSR)3-NH2 Conc.	p-FAK/FAK Ratio	p-ERK/ERK Ratio	p-Akt/Akt Ratio
Vehicle Control			
1 μ M			
10 μ M			
100 μ M			
500 μ M			
1 mM			
5 mM			

(Note: The tables above are templates. The actual concentrations and time points should be optimized for the specific cell line and experimental conditions.)

Conclusion

These detailed protocols and data presentation guidelines provide a robust framework for conducting comprehensive dose-response studies of **C(YIGSR)3-NH2**. By systematically evaluating its effects on cell viability, apoptosis, and key signaling pathways, researchers can gain valuable insights into its mechanism of action and determine its therapeutic potential.

Need Custom Synthesis?

BenchChem offers custom synthesis for rare earth carbides and specific isotopic labeling.

Email: info@benchchem.com or [Request Quote Online](#).

References

- 1. The laminin-derived peptide YIGSR (Tyr-Ile-Gly-Ser-Arg) inhibits human pre-B leukaemic cell growth and dissemination to organs in SCID mice - PMC [[pmc.ncbi.nlm.nih.gov](https://pubmed.ncbi.nlm.nih.gov/)]

- [2. Laminin Peptide YIGSR-NH2 - LKT Labs \[lktlabs.com\]](#)
- [3. 67-kDa laminin receptor increases cGMP to induce cancer-selective apoptosis - PMC \[pmc.ncbi.nlm.nih.gov\]](#)
- [4. research.brighton.ac.uk \[research.brighton.ac.uk\]](#)
- [5. YIGSR, A Laminin-Derived Peptide, Dictates a Concentration-Dependent Impact on Macrophage Phenotype Response - PMC \[pmc.ncbi.nlm.nih.gov\]](#)
- [6. researchgate.net \[researchgate.net\]](#)
- [7. YIGSR, A Laminin-Derived Peptide, Dictates a Concentration-Dependent Impact on Macrophage Phenotype Response - PubMed \[pubmed.ncbi.nlm.nih.gov\]](#)
- [8. dergipark.org.tr \[dergipark.org.tr\]](#)
- [9. The laminin \$\beta\$ 1-competing peptide YIGSR induces a hypercontractile, hypoproliferative airway smooth muscle phenotype in an animal model of allergic asthma - PMC \[pmc.ncbi.nlm.nih.gov\]](#)
- [10. broadpharm.com \[broadpharm.com\]](#)
- [11. home.sandiego.edu \[home.sandiego.edu\]](#)
- [12. Cell Viability Assays - Assay Guidance Manual - NCBI Bookshelf \[ncbi.nlm.nih.gov\]](#)
- [13. Annexin V staining assay protocol for apoptosis | Abcam \[abcam.com\]](#)
- [14. Protocol for Apoptosis Assay by Flow Cytometry Using Annexin V Staining Method - PMC \[pmc.ncbi.nlm.nih.gov\]](#)
- [15. Annexin V-FITC/PI staining for apoptosis evaluation \[bio-protocol.org\]](#)
- [16. Annexin V and PI Staining Protocol for Apoptosis by Flow Cytometry | Bio-Techne \[bio-techne.com\]](#)
- [17. Caspase-Glo® 3/7 Assay Protocol \[be.promega.com\]](#)
- [18. ulab360.com \[ulab360.com\]](#)
- [19. promega.com \[promega.com\]](#)
- [20. Laminin peptide YIGSR induces collagen synthesis in Hs27 human dermal fibroblasts - PubMed \[pubmed.ncbi.nlm.nih.gov\]](#)
- [21. researchgate.net \[researchgate.net\]](#)
- To cite this document: BenchChem. [Application Notes and Protocols for C(YIGSR)3-NH2 Dose-Response Studies]. BenchChem, [2026]. [Online PDF]. Available at: [\[https://www.benchchem.com/product/b126921/docs#application-notes-and-protocols-for-c-yigr-3-nh2-dose-response-studies\]](https://www.benchchem.com/product/b126921/docs#application-notes-and-protocols-for-c-yigr-3-nh2-dose-response-studies)

Disclaimer & Data Validity:

The information provided in this document is for Research Use Only (RUO) and is strictly not intended for diagnostic or therapeutic procedures. While BenchChem strives to provide accurate protocols, we make no warranties, express or implied, regarding the fitness of this product for every specific experimental setup.

Technical Support: The protocols provided are for reference purposes. Unsure if this reagent suits your experiment?

Need Industrial/Bulk Grade? [Request Custom Synthesis Quote](#)

BenchChem

Our mission is to be the trusted global source of essential and advanced chemicals, empowering scientists and researchers to drive progress in science and industry.

Contact

Address: 3281 E Guasti Rd
Ontario, CA 91761, United States
Phone: (601) 213-4426
Email: info@benchchem.com

[Contact our Ph.D. Support Team for a compatibility check](#)