

Independent Studies on the Biological Activity of Scalarin: A Comparative Guide

Author: BenchChem Technical Support Team. **Date:** April 2026

Compound of Interest

Compound Name: *Scalarin*
Cat. No.: *B1259260*

[Get Quote](#)

This guide provides a comprehensive comparison of the biological activities of **scalarin**, a marine natural product, with other relevant compounds. The information is compiled from independent studies to offer an objective resource for researchers, scientists, and drug development professionals. All quantitative data is summarized in tables, and detailed experimental protocols for key experiments are provided.

Overview of Scalarin's Biological Activity

Scalarin is a sesterterpene natural product originally isolated from the marine sponge *Euryspongia cf. rosea*.^[1] Its primary reported activities revolve around its effects on pancreatic cancer cells, specifically through the inhibition of the Receptor for Advanced Glycation End Products (RAGE) and autophagy.^{[1][2][3]} Structurally related scalarane compounds have also demonstrated a range of biological effects, including antimicrobial and anti-inflammatory activities.^{[4][5][6]}

Comparative Quantitative Data

Cytotoxicity of Scalarin vs. Curcumin in Pancreatic Cancer Cell Lines

Scalarin exhibits moderate cytotoxicity against several pancreatic cancer cell lines. Its potency is comparable to curcumin, a well-known natural compound, although curcumin generally shows higher cytotoxicity at lower concentrations.[1]

Compound	Cell Line	IC50 ($\mu\text{M} \pm \text{S.D.}$)
Scalarin	AsPC-1	>30
BxPC-3		>30
MIA PaCa-2		29.8 \pm 1.1
PANC-1		22.5 \pm 1.3
Curcumin	AsPC-1	13.0 \pm 0.9
BxPC-3		11.2 \pm 1.2
MIA PaCa-2		5.1 \pm 0.3
PANC-1		11.7 \pm 1.0

Data is presented as the average of 3 independent experiments.[1]

RAGE Inhibition by Scalarin

Scalarin has been shown to significantly reduce the expression levels of RAGE in a dose-dependent manner in pancreatic cancer cell lines.[1]

Cell Line	Scalarin Concentration (μM)	Result
PANC-1	11.3	Significant reduction in RAGE levels
22.5	Significant reduction in RAGE levels	
MIA PaCa-2	5.6	Significant reduction in RAGE levels
11.3	Significant reduction in RAGE levels	
22.5	Significant reduction in RAGE levels	

Significance determined by densitometry analysis of Western Blots.[1]

Biological Activities of Other Scalarane Sesterterpenoids

The scalarane chemical scaffold is found in various natural products that exhibit a range of biological activities.

Compound/Derivative	Activity	Organism(s)	MIC/IC50
Scalimides A–L	Antimicrobial	Micrococcus luteus, Bacillus subtilis	4 to 16 µg/mL
Lendenfeldaranes	Anti-inflammatory	Human neutrophils	IC50: 0.87 to 6.97 µM
Nambiscalarane	Antibacterial	Bacillus subtilis	MIC: 8 µg/mL
Heteronemin	Antimycobacterial	M. tuberculosis H37Rv	MIC: 6.25 µg/mL
Scalaradial	Anti-inflammatory	In vitro and in vivo models	Not specified

This table summarizes data from multiple independent studies.

[\[4\]](#)[\[6\]](#)[\[7\]](#)[\[8\]](#)[\[9\]](#)

Key Experimental Protocols

Cytotoxicity Assay

The concentration of **scalarin** required to induce 50% cytotoxicity (IC50) was determined using a nonlinear regression curve fit. Pancreatic cancer cell lines (AsPC-1, BxPC-3, MIA PaCa-2, and PANC-1) were treated with **scalarin** for 72 hours. The specific method for assessing cell viability (e.g., MTT or SRB assay) is a standard procedure in cytotoxicity testing.[\[1\]](#)[\[10\]](#)

RAGE Inhibition Screening Assay

- Cell Plating: PANC-1 cells were plated in a U-bottom plate and allowed to adhere overnight.
- Treatment: The media was replaced with fresh media containing the test compounds (e.g., 5µg/mL of test compounds, 30µM curcumin as a positive control) or vehicle controls.
- Incubation: Cells were incubated for 24 hours.

- Analysis: The expression of RAGE was determined using methods such as flow cytometry or Western blotting to quantify the reduction in RAGE levels.[1]

Inhibition of Autophagy Assay

- Cell Culture: PANC-1 and MIA PaCa-2 cells were plated and allowed to adhere overnight.
- Treatment: Cells were cultured in serum starvation media (no glutamate or FBS) to induce autophagy or treated with 10 µg/mL **scalarin** for various time points (0.5, 2, 6, 24, and 48 hours). Methanol served as a solvent control, and 10 µM manzamine A was used as a positive control for autophagy inhibition.
- Lysis and Western Blotting: Cells were lysed, and the protein extracts were subjected to Western Blotting to detect the levels of LC3-II, a known marker for autophagy. An accumulation of LC3-II indicates the inhibition of autophagy.[1]

Visualizations

Signaling Pathways and Experimental Workflows

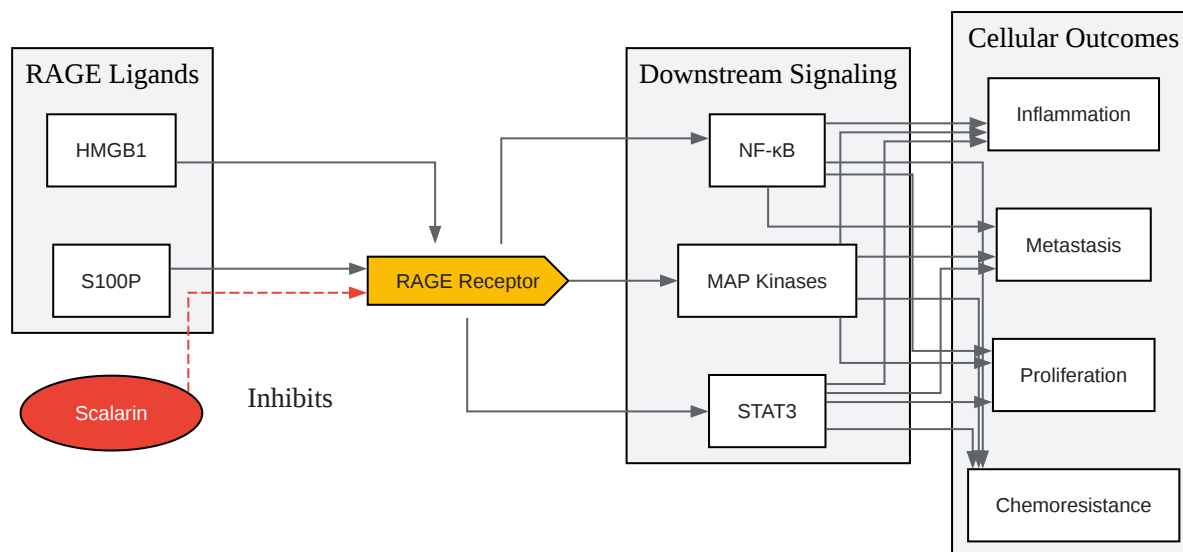

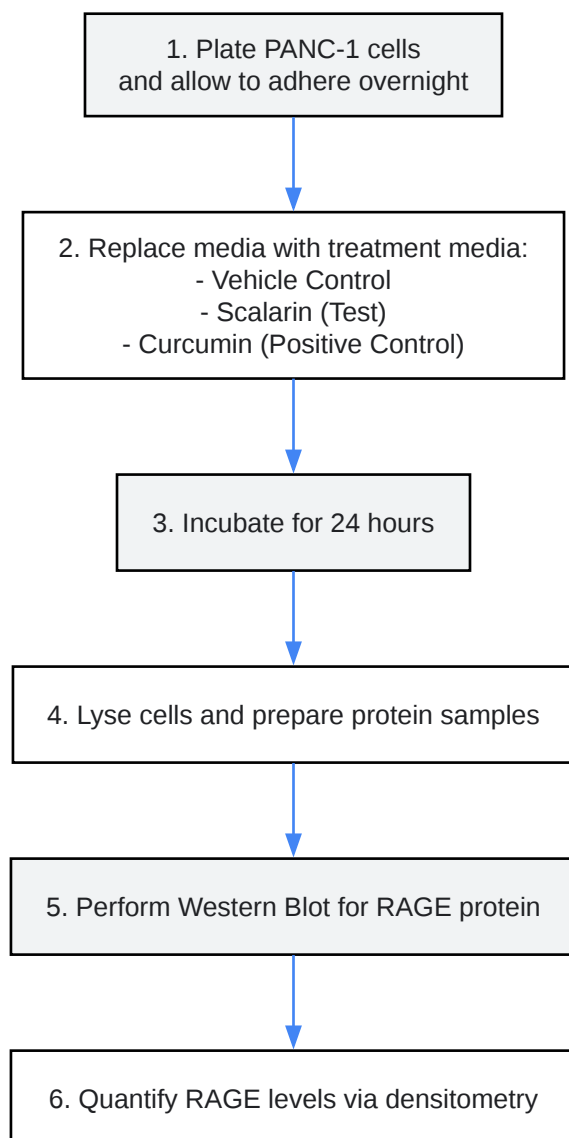

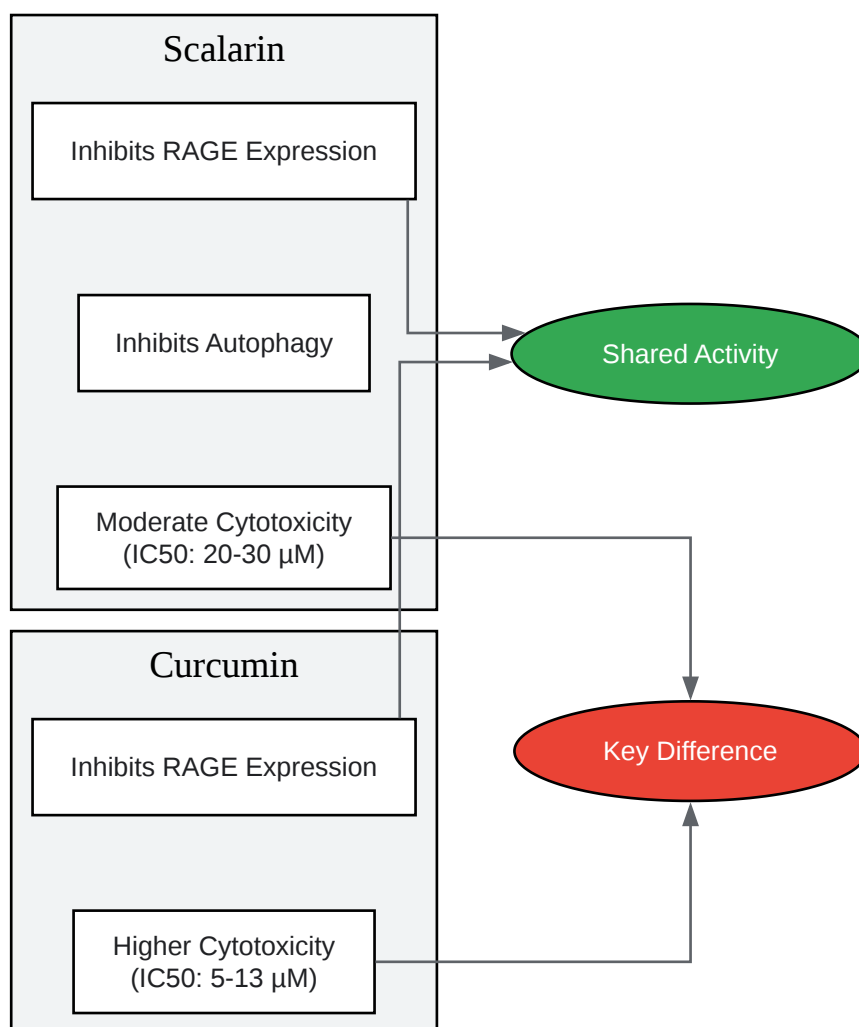

[Click to download full resolution via product page](#)

Need Custom Synthesis?

BenchChem offers custom synthesis for rare earth carbides and specific isotopic labeling.

Email: info@benchchem.com or [Request Quote Online](#).

References

- 1. The Marine Natural Product Scalarin Inhibits the Receptor for Advanced Glycation End Products (RAGE) and Autophagy in the PANC-1 and MIA PaCa-2 Pancreatic Cancer Cell Lines - PMC [[pmc.ncbi.nlm.nih.gov](https://pubmed.ncbi.nlm.nih.gov/)]

- 2. The marine natural product Scalarin inhibits the receptor for advanced glycation end products (RAGE) and autophagy in the PANC-1 and MIA PaCa-2 pancreatic cancer cell lines - PubMed [pubmed.ncbi.nlm.nih.gov]
- 3. The marine natural product Scalarin inhibits the receptor for advanced glycation end products (RAGE) and autophagy in the PANC-1 and MIA PaCa-2 pancreatic cancer cell lines. | Sigma-Aldrich [sigmaaldrich.com]
- 4. mdpi.com [mdpi.com]
- 5. mdpi.com [mdpi.com]
- 6. Anti-Helicobacter, Antitubercular and Cytotoxic Activities of Scalaranes from the Red Sea Sponge Hyrtios erectus - PMC [pmc.ncbi.nlm.nih.gov]
- 7. mdpi.com [mdpi.com]
- 8. Scalarane Sesterterpenoids with Antibacterial and Anti-Proliferative Activities from the Mushroom Neonothopanus nambi - PMC [pmc.ncbi.nlm.nih.gov]
- 9. researchgate.net [researchgate.net]
- 10. A comparison of clonogenic, microtetrazolium and sulforhodamine B assays for determination of cisplatin cytotoxicity in human ovarian carcinoma cell lines - PubMed [pubmed.ncbi.nlm.nih.gov]
- To cite this document: BenchChem. [Independent Studies on the Biological Activity of Scalarin: A Comparative Guide]. BenchChem, [2026]. [Online PDF]. Available at: [https://www.benchchem.com/product/b1259260/docs#independent-studies-on-the-biological-activity-of-scalarin-a-comparative-guide]

Disclaimer & Data Validity:

The information provided in this document is for Research Use Only (RUO) and is strictly not intended for diagnostic or therapeutic procedures. While BenchChem strives to provide accurate protocols, we make no warranties, express or implied, regarding the fitness of this product for every specific experimental setup.

Technical Support: The protocols provided are for reference purposes. Unsure if this reagent suits your experiment?

Need Industrial/Bulk Grade? [Request Custom Synthesis Quote](#)

BenchChem

Our mission is to be the trusted global source of essential and advanced chemicals, empowering scientists and researchers to drive progress in science and industry.

Contact

Address: 3281 E Guasti Rd

Ontario, CA 91761, United States

Phone: (601) 213-4426

Email: info@benchchem.com

[Contact our Ph.D. Support Team for a compatibility check](#)