

Bacopaside I vs. Synthetic Nootropics: A Comparative Efficacy Guide

Author: BenchChem Technical Support Team. **Date:** April 2026

Compound of Interest

Compound Name: *Bacopaside I*

CAS No.: 382148-47-2

Cat. No.: B1259160

[Get Quote](#)

In the ever-evolving landscape of cognitive enhancement, both natural compounds and synthetic drugs present compelling avenues for research and development. This guide offers a detailed comparison of **Bacopaside I**, a key bioactive saponin from the Ayurvedic herb *Bacopa monnieri*, against two well-established synthetic nootropics: Piracetam and Modafinil. This document is tailored for researchers, scientists, and drug development professionals, providing an objective analysis of their efficacy, supported by experimental data, detailed methodologies, and visualizations of their molecular interactions.

Comparative Efficacy: A Quantitative Overview

Direct head-to-head clinical trials comparing isolated **Bacopaside I** with synthetic nootropics are limited. However, by examining preclinical data and meta-analyses of clinical trials on *Bacopa monnieri* extracts (of which **Bacopaside I** is a major component) and synthetic nootropics, we can draw informative comparisons.

Table 1: Comparative Efficacy of **Bacopaside I**, Piracetam, and Modafinil on Cognitive Domains

| Cognitive Domain | Bacopaside I (from Bacopa monnieri extracts) | Piracetam | Modafinil |
|--------------------|--|--|---|
| Memory | Significant improvement in delayed word recall (Effect Size: 0.95)[1] | Mixed results; some studies show no significant improvement in memory enhancement (SMD 0.75; p=0.12) | Enhanced visual pattern recognition memory and digit span[2] |
| Attention | Improved speed of attention (shortened Trail B test time by -17.9 ms)[3] | Evidence for efficacy is not well-supported by published data[4] | Selective improvement in attention, particularly in inhibiting pre-potent responses[5][2] |
| Executive Function | --- | Limited evidence of benefit[4] | Improved performance on spatial planning tasks[5][2] |
| Reaction Time | Decreased choice reaction time (-10.6 ms)[3] | --- | Slowing in latency on some decision-making tasks[5][2] |

Mechanisms of Action: A Divergent Approach to Cognitive Enhancement

Bacopaside I and synthetic nootropics employ distinct molecular mechanisms to exert their cognitive-enhancing effects.

Bacopaside I operates through a multi-target approach. Its neuroprotective effects are attributed to its antioxidant properties, including the scavenging of free radicals and suppression of lipid peroxidation[6]. It also modulates the expression of neuroreceptors like AMPAR, NMDAR, and GABAR and has been shown to play a role in neuroprotective signaling via PKC and PI3K/Akt pathways[6]. Furthermore, **Bacopaside I** has been found to increase cerebral blood flow, which can contribute to enhanced cognitive function[7].

Piracetam, the first of the racetam class of nootropics, is believed to enhance cognitive function by modulating neurotransmitter systems, particularly the cholinergic and glutamatergic systems[8][9]. It is thought to increase the density of acetylcholine receptors and enhance the activity of AMPA and NMDA receptors, which are crucial for learning and memory[8][10].

Modafinil primarily acts as a weak dopamine reuptake inhibitor, thereby increasing the concentration of dopamine in the synaptic cleft[11]. This action is thought to be central to its wakefulness-promoting and cognitive-enhancing effects[11][12]. Modafinil also influences other neurotransmitter systems, including norepinephrine, serotonin, and glutamate[11][13].

Signaling Pathway Visualizations

The following diagrams illustrate the proposed signaling pathways for **Bacopaside I**, Piracetam, and Modafinil.

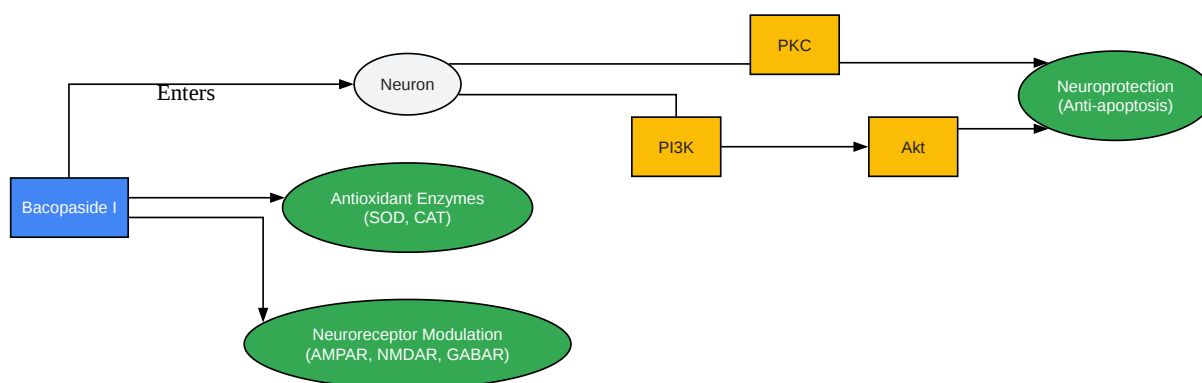

[Click to download full resolution via product page](#)

Bacopaside I Neuroprotective Pathways

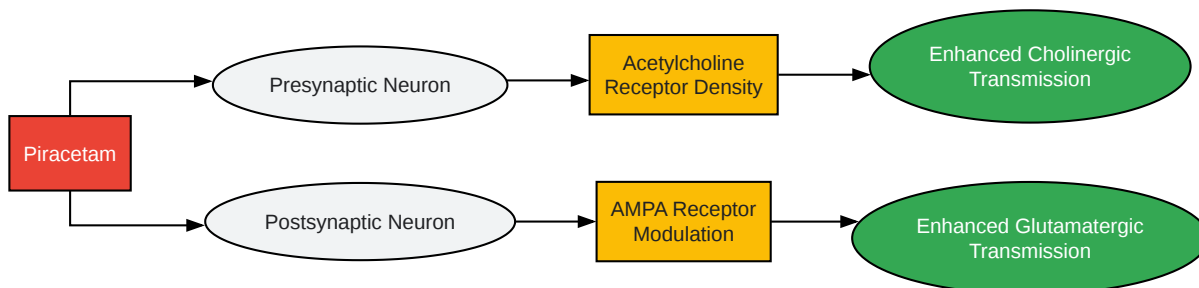

[Click to download full resolution via product page](#)

Piracetam's Influence on Neurotransmission

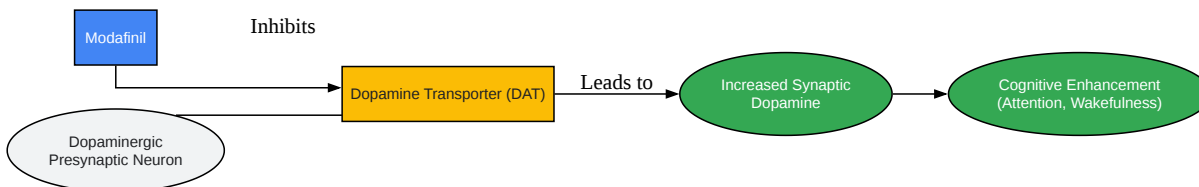

[Click to download full resolution via product page](#)

Modafinil's Dopaminergic Mechanism

Experimental Protocols: A Methodological Overview

The following sections detail typical experimental designs used to evaluate the efficacy of these nootropic agents.

Bacopaside I (Bacopa monnieri Extract) Clinical Trial Protocol

- Study Design: Randomized, double-blind, placebo-controlled trial.[14][15]
- Participants: Healthy adult volunteers or elderly individuals without dementia.[14][15]
- Intervention: Daily oral administration of a standardized Bacopa monnieri extract (e.g., 300 mg containing a specified percentage of bacosides) or placebo for a period of 12 weeks.[14][15]
- Cognitive Assessment: A battery of neuropsychological tests is administered at baseline and at specified intervals throughout the study. Key assessments often include:
 - Rey Auditory Verbal Learning Test (AVLT) for memory.[15]
 - Stroop Task for executive function.[15]
 - Trail Making Test (TMT) for attention and processing speed.[3]
 - Choice Reaction Time tests.[3]
- Outcome Measures: Primary outcomes typically focus on changes in scores on the cognitive tests from baseline to the end of the treatment period, compared between the active and placebo groups.

Piracetam Clinical Trial Protocol for Cognitive Impairment

- Study Design: Randomized, double-blind, placebo-controlled, parallel-group trial.[4][16]
- Participants: Patients diagnosed with dementia (e.g., Alzheimer's type or vascular) or mild cognitive impairment.[4][17]
- Intervention: Oral administration of Piracetam (doses ranging from 2.4 to 9.6 g/day) or placebo for a duration of at least 12 weeks, with some trials extending to 12 months.[16][17]
- Cognitive Assessment:

- Clinician's Global Impression of Change (CGIC) as a primary outcome measure.[4][16]
- Psychometric tests such as the Mini-Mental State Examination (MMSE) and Alzheimer's Disease Assessment Scale-Cognitive subscale (ADAS-Cog).[4]
- Outcome Measures: The primary endpoint is often the proportion of patients showing improvement on the CGIC scale. Secondary outcomes include changes in cognitive test scores.

Modafinil Clinical Trial Protocol in Healthy Adults

- Study Design: Randomized, double-blind, placebo-controlled, between-subjects design.[5][2]
- Participants: Healthy, non-sleep-deprived young adult volunteers.[5][2]
- Intervention: A single oral dose of Modafinil (e.g., 100 mg or 200 mg) or placebo administered prior to cognitive testing.[5][2]
- Cognitive Assessment: A comprehensive battery of tests to assess various cognitive domains, including:
 - Digit Span for working memory.[5][2]
 - Visual Pattern Recognition Memory tasks.[5][2]
 - Spatial Planning tasks for executive function.[5][2]
 - Stop-Signal Reaction Time for response inhibition.[5][2]
- Outcome Measures: Performance on the cognitive tasks, including accuracy and reaction times, are compared between the Modafinil and placebo groups.

Experimental Workflow Visualization

The following diagram illustrates a typical workflow for a preclinical study evaluating the neuroprotective effects of a nootropic compound.

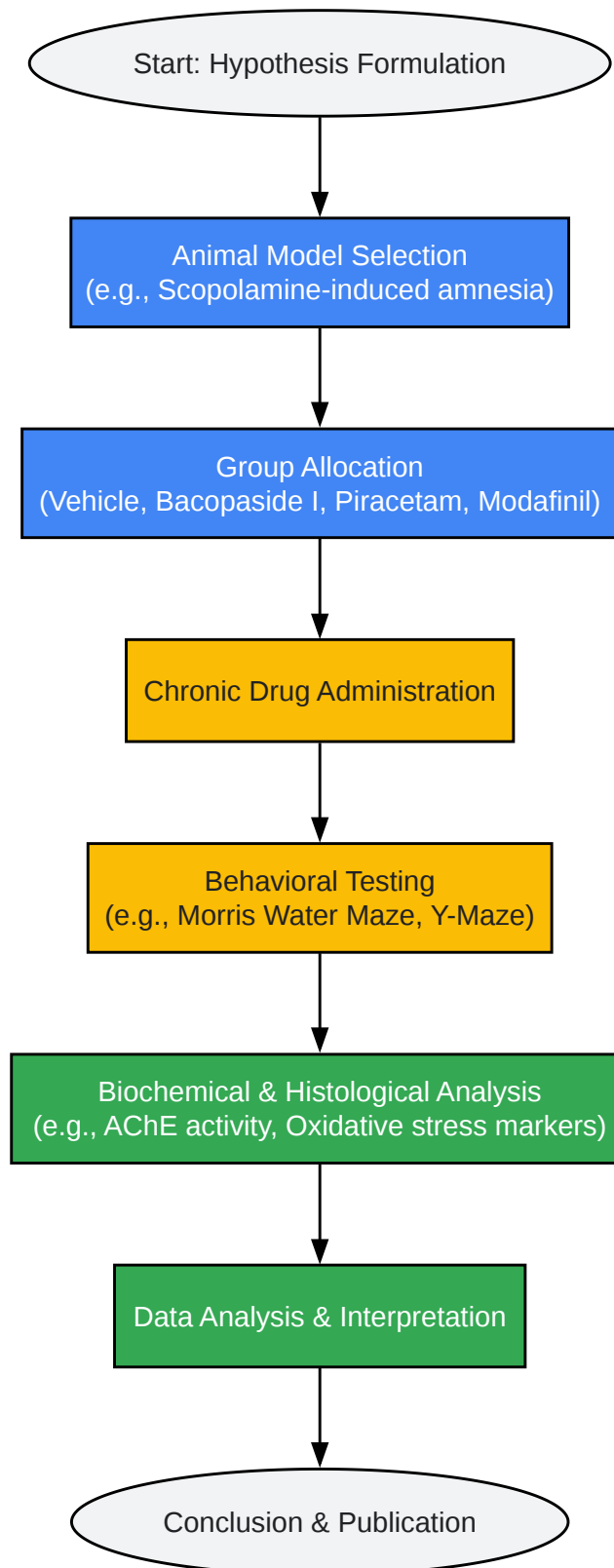

[Click to download full resolution via product page](#)

Preclinical Nootropic Evaluation Workflow

Conclusion

Bacopaside I, as a key component of *Bacopa monnieri*, demonstrates significant potential as a cognitive enhancer, particularly in the domain of memory, with a multifaceted mechanism of action centered on neuroprotection and neurotransmitter modulation. Synthetic nootropics like Piracetam and Modafinil offer more targeted approaches, with Piracetam influencing cholinergic and glutamatergic pathways and Modafinil primarily acting on the dopaminergic system.

While the available data suggests that the cognitive-enhancing effects of *Bacopa monnieri* extracts can be comparable in magnitude to those of synthetic nootropics, the onset of action may differ, with **Bacopaside I** often requiring chronic administration for noticeable benefits. The choice between these compounds for future research and development will depend on the specific therapeutic target, desired mechanism of action, and safety profile. Further head-to-head clinical trials are warranted to definitively establish the comparative efficacy of isolated **Bacopaside I** against these synthetic alternatives.

Need Custom Synthesis?

BenchChem offers custom synthesis for rare earth carbides and specific isotopic labeling.

Email: info@benchchem.com or [Request Quote Online](#).

References

- [1. benchchem.com \[benchchem.com\]](#)
- [2. researchgate.net \[researchgate.net\]](#)
- [3. Meta-analysis of randomized controlled trials on cognitive effects of *Bacopa monnieri* extract - PubMed \[pubmed.ncbi.nlm.nih.gov\]](#)
- [4. Piracetam for dementia or cognitive impairment - PMC \[pmc.ncbi.nlm.nih.gov\]](#)
- [5. Cognitive enhancing effects of modafinil in healthy volunteers - PubMed \[pubmed.ncbi.nlm.nih.gov\]](#)
- [6. Insights into the Molecular Aspects of Neuroprotective Bacoside A and Bacopaside I - PMC \[pmc.ncbi.nlm.nih.gov\]](#)

- 7. Modafinil Increases the Latency of Response in the Hayling Sentence Completion Test in Healthy Volunteers: A Randomised Controlled Trial | PLOS One [journals.plos.org]
- 8. What is the mechanism of Piracetam? [synapse.patsnap.com]
- 9. Piracetam: A Review of Pharmacological Properties and Clinical Uses - PMC [pmc.ncbi.nlm.nih.gov]
- 10. Piracetam - Wikipedia [en.wikipedia.org]
- 11. What is the mechanism of Modafinil? [synapse.patsnap.com]
- 12. Effects of Modafinil on Dopamine and Dopamine Transporters in the Male Human Brain: Clinical Implications - PMC [pmc.ncbi.nlm.nih.gov]
- 13. The neurobiology of modafinil as an enhancer of cognitive performance and a potential treatment for substance use disorders - PMC [pmc.ncbi.nlm.nih.gov]
- 14. pdfs.semanticscholar.org [pdfs.semanticscholar.org]
- 15. Effects of a Standardized Bacopa monnieri Extract on Cognitive Performance, Anxiety, and Depression in the Elderly: A Randomized, Double-Blind, Placebo-Controlled Trial - PMC [pmc.ncbi.nlm.nih.gov]
- 16. Clinical efficacy of piracetam in cognitive impairment: a meta-analysis - Database of Abstracts of Reviews of Effects (DARE): Quality-assessed Reviews - NCBI Bookshelf [ncbi.nlm.nih.gov]
- 17. ClinicalTrials.gov [clinicaltrials.gov]
- To cite this document: BenchChem. [Bacopaside I vs. Synthetic Nootropics: A Comparative Efficacy Guide]. BenchChem, [2026]. [Online PDF]. Available at: [https://www.benchchem.com/product/b1259160/docs#bacopaside-i-vs-synthetic-nootropics-a-comparative-efficacy-guide]

Disclaimer & Data Validity:

The information provided in this document is for Research Use Only (RUO) and is strictly not intended for diagnostic or therapeutic procedures. While BenchChem strives to provide accurate protocols, we make no warranties, express or implied, regarding the fitness of this product for every specific experimental setup.

Technical Support: The protocols provided are for reference purposes. Unsure if this reagent suits your experiment?

Need Industrial/Bulk Grade? [Request Custom Synthesis Quote](#)

BenchChem

Our mission is to be the trusted global source of essential and advanced chemicals, empowering scientists and researchers to drive progress in science and industry.

Contact

Address: 3281 E Guasti Rd
Ontario, CA 91761, United States
Phone: (601) 213-4426
Email: info@benchchem.com

[Contact our Ph.D. Support Team for a compatibility check](#)