

Technical Support Center: Temperature Control for Bromination of Phenolic Esters

Author: BenchChem Technical Support Team. **Date:** April 2026

Compound of Interest

Compound Name: *Methyl 2,6-dibromo-3,5-dihydroxybenzoate*

Cat. No.: *B12583956*

[Get Quote](#)

Welcome to the Technical Support Center for the bromination of phenolic esters. This resource is designed for researchers, scientists, and professionals in drug development who are navigating the complexities of this crucial synthetic transformation. Here, you will find in-depth troubleshooting guides and frequently asked questions (FAQs) to address specific challenges encountered during your experiments, with a strong focus on the critical role of temperature in controlling reaction outcomes.

Introduction: The Energetic Landscape of Bromination

The bromination of phenolic esters is a classic example of electrophilic aromatic substitution. The ester group, while less activating than a hydroxyl group, still directs incoming electrophiles to the ortho and para positions. The inherent reactivity of the aromatic ring, coupled with the exothermic nature of bromination, makes precise temperature control paramount. Failure to manage the thermal profile of the reaction can lead to a cascade of undesirable outcomes, including polysubstitution, poor regioselectivity, and, in worst-case scenarios, dangerous runaway reactions.

This guide is structured to help you understand the "why" behind the "how," enabling you to not only follow protocols but also to troubleshoot and optimize your reactions with a solid understanding of the underlying chemical principles.

Frequently Asked Questions (FAQs)

Q1: My reaction is producing a mixture of mono-, di-, and even tri-brominated products. How can I improve the selectivity for mono-bromination?

A1: Polysubstitution is a common challenge due to the activating nature of the oxygen atom attached to the aromatic ring. The key to achieving mono-selectivity lies in moderating the reaction's reactivity.

- **Primary Cause:** The high electrophilicity of the brominating agent and the activated nature of the phenolic ester ring.
- **Temperature's Role:** Higher temperatures increase the reaction rate, providing sufficient energy for multiple bromination events to occur before the initial product can be isolated.
- **Solutions & Causality:**
 - **Lower the Reaction Temperature:** This is the most critical parameter. Reducing the temperature (e.g., to 0 °C, -10 °C, or even lower) decreases the kinetic energy of the system. This makes the aromatic ring less nucleophilic and slows the reaction rate, allowing for the addition of a single bromine atom before further reactions can take place. [\[1\]](#)
 - **Slow Addition of Brominating Agent:** Adding the brominating agent dropwise over an extended period prevents a localized excess of the electrophile, which can lead to rapid, uncontrolled polysubstitution.
 - **Choice of Brominating Agent:** Use a milder brominating agent. N-Bromosuccinimide (NBS) is often preferred over elemental bromine (Br₂) as it provides a lower equilibrium concentration of Br₂, leading to a more controlled reaction. [\[2\]](#)[\[3\]](#)

- Solvent Selection: Non-polar solvents, such as carbon tetrachloride (CCl_4) or dichloromethane (CH_2Cl_2), can reduce the reactivity of the brominating agent compared to polar solvents.

Q2: I am getting a mixture of ortho and para isomers. How can I selectively synthesize the para or ortho product?

A2: The ratio of ortho to para isomers is governed by a delicate interplay of sterics, electronics, and reaction conditions, a concept best understood through the principles of kinetic and thermodynamic control.

- Kinetic vs. Thermodynamic Control:
 - The kinetic product is the one that forms the fastest, having the lowest activation energy. For many phenolic esters, the ortho position is sterically more accessible for the initial attack, but the resulting intermediate can be destabilized by steric hindrance.
 - The thermodynamic product is the most stable product. The para isomer often experiences less steric hindrance and is, therefore, the more thermodynamically stable product.
- Temperature's Influence:
 - Low Temperatures (Kinetic Control): At lower temperatures, the reaction is essentially irreversible. The product distribution is determined by the relative rates of formation. If the activation energy for the formation of the ortho product is lower, it may be favored under these conditions. However, for many substrates, the para product is still predominantly formed due to a combination of electronic and steric factors even at low temperatures.[1]
[4]
 - Higher Temperatures (Thermodynamic Control): At elevated temperatures, the reaction can become reversible. This allows the initially formed products to revert to the carbocation intermediate and re-form. Over time, the product mixture will equilibrate to favor the most stable isomer, which is typically the para product. However, higher temperatures can also lead to more side products.[4]

- Practical Strategies for Regioselectivity:
 - For para-selectivity: Conduct the reaction at the lowest effective temperature that allows for a reasonable reaction rate. This often enhances the preference for the thermodynamically favored, sterically less hindered para position.[1] For example, the bromination of phenyl acetate with zeolites as catalysts shows high para-selectivity.[5]
 - For ortho-selectivity: This is generally more challenging. It may require the use of a directing group or specific catalysts that can chelate with the ester and bromine, favoring substitution at the proximate ortho position. Some methods using bromine chloride at moderate temperatures have shown increased ortho-selectivity.[6]

Troubleshooting Guide

Issue	Observable Symptoms	Probable Causes	Troubleshooting Steps & Explanations
Poor Regioselectivity (Undesired ortho/para ratio)	GC-MS or NMR analysis shows a mixture of ortho and para isomers.	1. Reaction temperature is too high, allowing for the formation of the thermodynamically controlled product mixture. 2. Solvent effects are influencing the transition state energies for ortho and para attack differently.	1. Lower the reaction temperature significantly. For enhanced para-selectivity, try running the reaction at 0 °C, -10 °C, or even as low as -78 °C.[1][7] This will favor the kinetically controlled pathway, which often leads to a higher proportion of a single isomer. 2. Screen different solvents. The polarity of the solvent can influence the stability of the intermediates and transition states. Compare results in non-polar (e.g., CCl ₄ , hexane) and polar aprotic (e.g., CH ₂ Cl ₂ , acetonitrile) solvents. [8]
Polysubstitution	Multiple spots on TLC; GC-MS shows peaks for di- and tri-brominated products; lower than expected yield of the mono-brominated product.	1. Reaction temperature is too high, leading to a fast, uncontrolled reaction. 2. High concentration of brominating agent. 3. Use of a highly	1. Perform the reaction at a lower temperature (e.g., 0 °C or below). 2. Add the brominating agent slowly and dropwise using a syringe pump

		reactive brominating agent (e.g., Br ₂ in a polar solvent).	or a dropping funnel to maintain a low concentration at all times. 3. Switch to a milder brominating agent like N-Bromosuccinimide (NBS).[9]
Runaway Reaction	Rapid, uncontrolled increase in temperature and pressure; vigorous gas evolution; change in color of the reaction mixture.	1. Reaction is highly exothermic. 2. Inadequate cooling. 3. Incorrect order of addition or too rapid addition of reagents. 4. Unforeseen side reaction, e.g., between NBS and certain solvents like 2-MeTHF.	1. Always conduct a thermal hazard assessment before scaling up. 2. Ensure adequate cooling capacity. Use an appropriate cooling bath (ice-water, dry ice-acetone) and a flask size that allows for efficient heat transfer. 3. Add the brominating agent slowly and monitor the internal temperature. 4. Carefully select your solvent. Be aware of known incompatibilities.[3]
Low or No Conversion	TLC or GC-MS shows unreacted starting material.	1. Reaction temperature is too low. 2. Insufficiently activated brominating agent. 3. Deactivated substrate.	1. Gradually increase the temperature. If the reaction is clean but slow at a low temperature, a modest increase may be necessary. 2. Consider adding a Lewis acid catalyst (e.g., FeBr ₃ , AlCl ₃) if

using Br₂, but be aware this will significantly increase reactivity and may require even lower temperatures to control. 3. For deactivated phenolic esters (with electron-withdrawing groups), more forcing conditions (higher temperature, stronger brominating agent) may be required.^[10]

Data Presentation: Temperature's Influence on Regioselectivity

The following table summarizes the effect of temperature on the product distribution for the bromination of representative phenolic compounds. Note that the exact ratios are highly dependent on the substrate, solvent, and brominating agent.

Substrate	Brominating Agent	Solvent	Temperature (°C)	Ortho:Para Ratio	Comments	Reference(s)
Phenol	Br ₂	Gas Phase	200	Increases with temp	At higher temperatures, the ortho to para ratio increases.	[11]
Phenol	BrCl	CCl ₄	0	-	Example of ortho-selective conditions.	[6]
Phenol	BrCl	CCl ₄	25	0.9:1	Ortho to para ratio.	[6]
Phenol	BrCl	CCl ₄	40	1.1:1	Ortho to para ratio increases with temperature.	[6]
Phenyl Acetate	Br ₂ with Zeolite	Not Specified	Not Specified	Highly para-selective	Zeolites can promote para-selectivity by removing HBr.	[5]
Catechol	NBS, HBF ₄	Acetonitrile	-30	100% para	Low temperature is crucial for high regioselectivity.	[1]

p-cresol	NBS, pTsOH	Methanol	~20	94% ortho	In this case, the para position is blocked, leading to ortho-bromination. [2]
o-chlorophenol	BrCl	CCl ₄	25	3.9:1 (6-bromo:4-bromo)	Demonstrates influence of existing substituents and temperature. [6]

Experimental Protocols

Protocol 1: Highly para-Selective Bromination of a Phenolic Ester at Low Temperature

This protocol is a general guideline for achieving high para-selectivity. The specific substrate and scale will require optimization.

- **Setup:** In a flame-dried, three-necked round-bottom flask equipped with a magnetic stirrer, a thermometer, and a nitrogen inlet, dissolve the phenolic ester (1.0 eq.) in a suitable anhydrous solvent (e.g., dichloromethane or acetonitrile).
- **Cooling:** Cool the solution to the desired low temperature (e.g., -30 °C) using a dry ice/acetone bath.
- **Reagent Preparation:** In a separate, dry flask, dissolve N-bromosuccinimide (NBS) (1.05 eq.) in the same anhydrous solvent.

- **Slow Addition:** Add the NBS solution to the cooled solution of the phenolic ester dropwise via a syringe pump over 1-2 hours, ensuring the internal temperature does not rise significantly.
- **Reaction Monitoring:** Monitor the progress of the reaction by thin-layer chromatography (TLC) or gas chromatography-mass spectrometry (GC-MS).
- **Quenching:** Once the starting material is consumed, quench the reaction by adding a saturated aqueous solution of sodium thiosulfate.
- **Work-up:** Allow the mixture to warm to room temperature. Separate the organic layer, and extract the aqueous layer with the solvent. Combine the organic layers, wash with brine, dry over anhydrous sodium sulfate, and concentrate under reduced pressure.
- **Purification:** Purify the crude product by column chromatography or recrystallization.

Protocol 2: Safety Protocol for Scaling Up Bromination Reactions

Scaling up bromination reactions requires careful planning to mitigate the risk of a runaway reaction.

- **Hazard Assessment:** Before scaling up, perform a thorough literature search for any known hazards associated with the specific reaction. Consult resources like Bretherick's Handbook of Reactive Chemical Hazards.
- **Small-Scale Trial:** Always perform the reaction on a small scale first to observe its behavior.
- **Incremental Scale-Up:** Do not increase the scale by more than a factor of three to five at a time.^[6]
- **Ensure Adequate Cooling:** Use a reaction vessel with a large surface area-to-volume ratio and a cooling system with sufficient capacity to handle the heat generated.
- **Controlled Addition:** Use a syringe pump or a dropping funnel for the slow, controlled addition of the limiting reagent.

- Continuous Monitoring: Continuously monitor the internal temperature of the reaction. Have a large cooling bath on standby in case of an unexpected exotherm.
- Emergency Plan: Have a clear plan for quenching the reaction in an emergency, such as the rapid addition of a quenching agent or submersion in a large ice bath.

Visualizations

Reaction Mechanism and Temperature Influence

The following diagram illustrates the general mechanism for the electrophilic bromination of a phenolic ester and highlights the competing pathways to the ortho and para products.

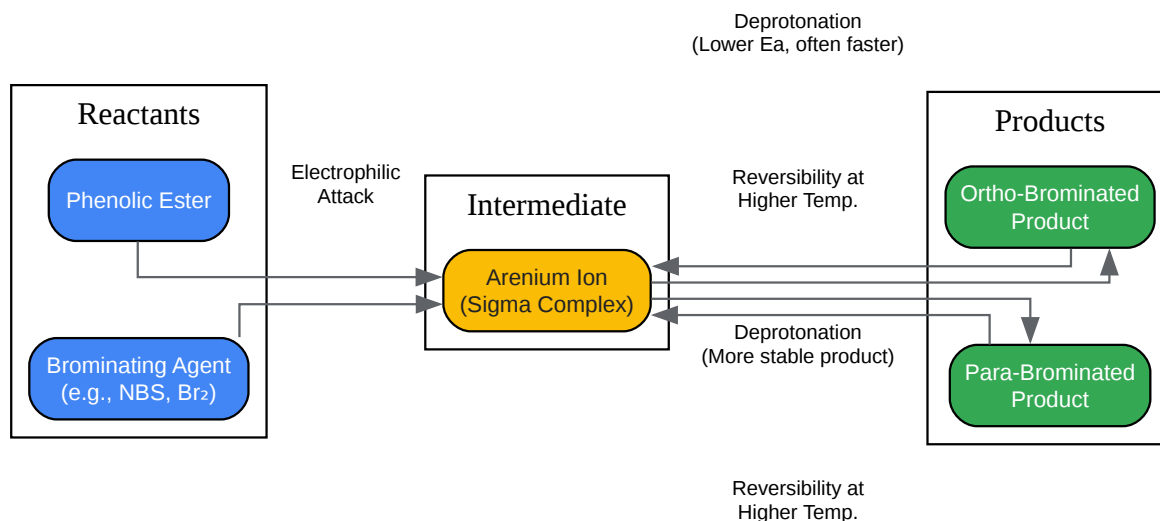

[Click to download full resolution via product page](#)

Caption: Mechanism of electrophilic bromination and competing pathways.

Kinetic vs. Thermodynamic Control

This diagram illustrates the energy profile for the formation of the kinetic (ortho) and thermodynamic (para) products.

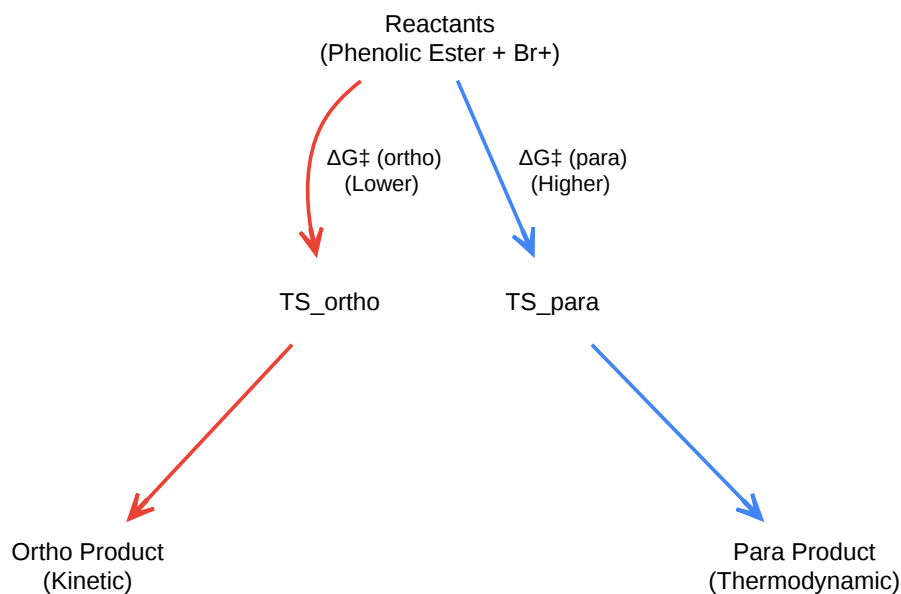

[Click to download full resolution via product page](#)

Caption: Energy profile of kinetic vs. thermodynamic control.

Troubleshooting Workflow

A logical workflow for diagnosing and solving common issues in the bromination of phenolic esters.

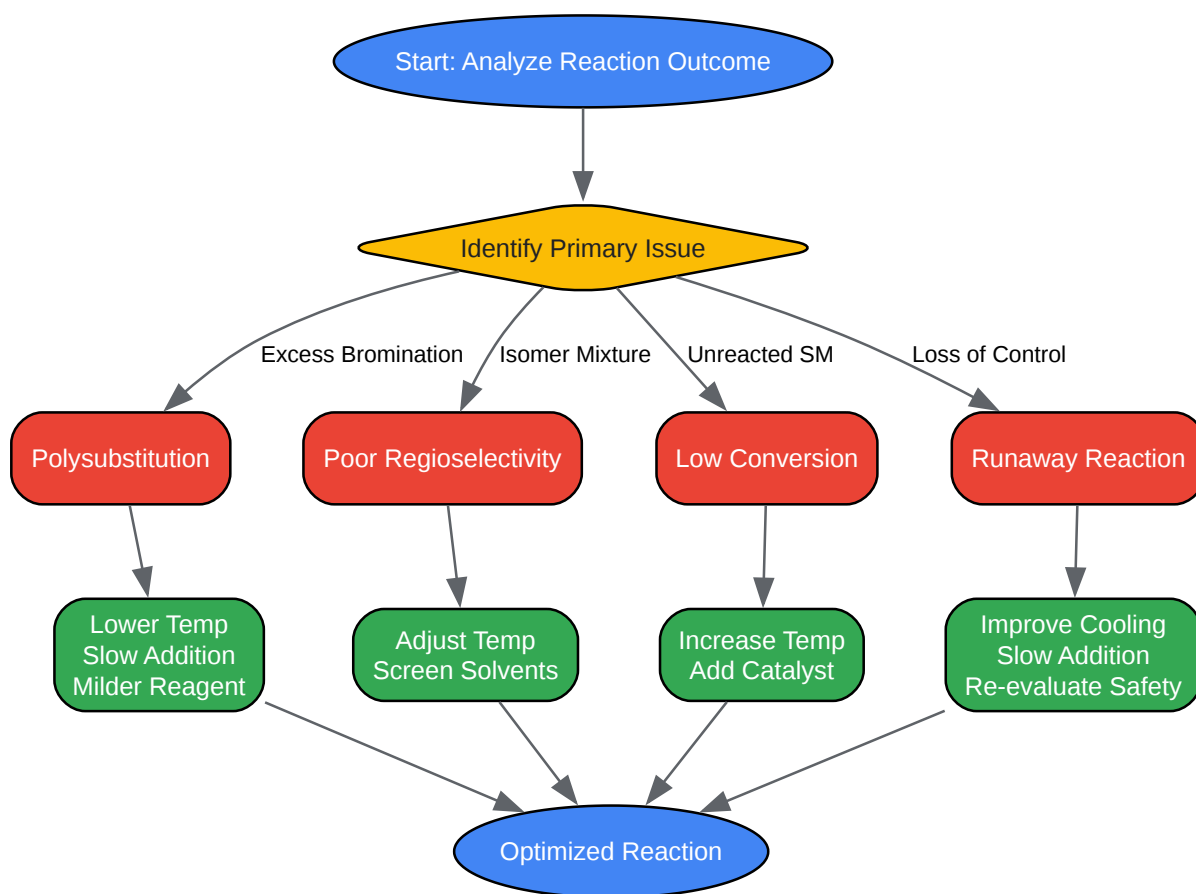

[Click to download full resolution via product page](#)

Caption: Troubleshooting workflow for bromination reactions.

References

- Li, H.-J., Wu, Y.-C., Dai, J.-H., Song, Y., Cheng, R., & Qiao, Y. (2014). Regioselective Electrophilic Aromatic Bromination: Theoretical Analysis and Experimental Verification. *Molecules*, 19(3), 3401–3416. [[Link](#)]
- Mills, L. T., & Mills, R. W. (1969). U.S. Patent No. 3,449,443. Washington, DC: U.S.
- Georgiev, D., Saes, B. W. H., Johnston, H. J., Boyle, S. K., Healy, A., & Hulme, A. N. (2016). Selective and Efficient Generation of ortho-Brominated para-Substituted Phenols in ACS-Grade Methanol. *Molecules*, 21(1), 93. [[Link](#)]

- LibreTexts. (2021). 14.3: Kinetic vs. Thermodynamic Control of Reactions. Chemistry LibreTexts. [\[Link\]](#)
- Li, H.-J., Wu, Y.-C., Dai, J.-H., Song, Y., Cheng, R., & Qiao, Y. (2014). Regioselective Electrophilic Aromatic Bromination: Theoretical Analysis and Experimental Verification. *Molecules*, 19(3), 3401–3416. [\[Link\]](#)
- LibreTexts. (2021). 3.3: Kinetic vs. Thermodynamic Control of Reactions. Chemistry LibreTexts. [\[Link\]](#)
- Wibaut, J. P., & van de Lande, L. M. F. (1933). On the bromination of phenol in the gas phase at temperatures between 200° and 500°. *Recueil des Travaux Chimiques des Pays-Bas*, 52(5), 413-422. [\[Link\]](#)
- Lopez, L., & Ciminale, F. (1974). Solvent effect on the ortho: para ratio in the bromination of phenols. Bromination with bromocyclohexadienones and N-bromosuccinimide. *Journal of the Chemical Society, Perkin Transactions 2*, (5), 529-531. [\[Link\]](#)
- Guan, M., Tian, Y., Zhao, J., Gu, W., Jiang, X., Wang, X., ... & Zhang, X. (2021). Safe Scale-Up of a NBS-Involved Bromination Reaction: Thermal Safety Analysis Contributes to Process Optimization. *Organic Process Research & Development*, 25(6), 1375–1382. [\[Link\]](#)
- Bay, V., & Cakmak, M. (2017). Unexpected regioselectivity observed in the bromination and epoxidation reactions of p-benzoquinone-fused norbornadiene: An experimental and computational study. *Tetrahedron*, 73(10), 1369-1375. [\[Link\]](#)
- Smith, K., He, P., & Taylor, A. (1999). Selective para-bromination of phenyl acetate under the control of zeolites, bases, acetic anhydride or metal acetates in the liquid phase. *Green Chemistry*, 1(1), 35-38. [\[Link\]](#)
- Satkar, Y., Ramadoss, V., Nahide, P., Mendoza, R. G., & Solorio-Alvarado, C. R. (2018). Practical, mild and efficient electrophilic bromination of phenols by a new I(iii)-based reagent: the PIDA–AlBr₃ system. *RSC advances*, 8(31), 17350-17359. [\[Link\]](#)
- Satkar, Y., Ramadoss, V., Nahide, P., Mendoza, R. G., & Solorio-Alvarado, C. R. (2018). Practical, mild and efficient electrophilic bromination of phenols by a new I(iii)-based reagent: the PIDA–AlBr₃ system. *RSC advances*, 8(31), 17350-17359. [\[Link\]](#)

- University of Waterloo. (n.d.). Kinetic & Thermodynamic Control. Foundations of Chemical and Biological Engineering I. [[Link](#)]
- Organic Chemistry Portal. (n.d.). N-Bromosuccinimide (NBS). [[Link](#)]

Need Custom Synthesis?

BenchChem offers custom synthesis for rare earth carbides and specific isotopic labeling.

Email: info@benchchem.com or [Request Quote Online](#).

Sources

1. [mdpi.com](https://www.mdpi.com) [[mdpi.com](https://www.mdpi.com)]
 2. Selective and Efficient Generation of ortho-Brominated para-Substituted Phenols in ACS-Grade Methanol [[mdpi.com](https://www.mdpi.com)]
 3. Selective and Efficient Generation of ortho-Brominated para-Substituted Phenols in ACS-Grade Methanol - PMC [[pmc.ncbi.nlm.nih.gov](https://pubmed.ncbi.nlm.nih.gov/)]
 4. 14.3 Kinetic versus Thermodynamic Control of Reactions – Organic Chemistry: A Tenth Edition – OpenStax adaptation 1 [[ncstate.pressbooks.pub](https://openstax.org/r/ncstate-pressbooks-pub)]
 5. [discovery.researcher.life](https://www.discovery.researcher.life) [[discovery.researcher.life](https://www.discovery.researcher.life)]
 6. US3449443A - Method for selectively brominating phenols - Google Patents [patents.google.com]
 7. Unexpected regioselectivity observed in the bromination and epoxidation reactions of p-benzoquinone-fused norbornadiene: An experimental and computational study [[agris.fao.org](https://www.agris.fao.org)]
 8. Solvent effect on the ortho : para ratio in the bromination of phenols. Bromination with bromocyclohexadienones and N-bromosuccinimide - Journal of the Chemical Society, Perkin Transactions 2 (RSC Publishing) [pubs.rsc.org]
 9. N-Bromosuccinimide (NBS) [[organic-chemistry.org](https://www.organic-chemistry.org)]
 10. Practical, mild and efficient electrophilic bromination of phenols by a new I(III)-based reagent: the PIDA–AlBr₃ system - PMC [[pmc.ncbi.nlm.nih.gov](https://pubmed.ncbi.nlm.nih.gov/)]
 11. [researchgate.net](https://www.researchgate.net) [[researchgate.net](https://www.researchgate.net)]
- To cite this document: BenchChem. [Technical Support Center: Temperature Control for Bromination of Phenolic Esters]. BenchChem, [2026]. [Online PDF]. Available at:

[<https://www.benchchem.com/product/b12583956/docs#technical-support-center-temperature-control-for-bromination-of-phenolic-esters>]

Disclaimer & Data Validity:

The information provided in this document is for Research Use Only (RUO) and is strictly not intended for diagnostic or therapeutic procedures. While BenchChem strives to provide accurate protocols, we make no warranties, express or implied, regarding the fitness of this product for every specific experimental setup.

Technical Support: The protocols provided are for reference purposes. Unsure if this reagent suits your experiment?

Need Industrial/Bulk Grade? [Request Custom Synthesis Quote](#)

BenchChem

Our mission is to be the trusted global source of essential and advanced chemicals, empowering scientists and researchers to drive progress in science and industry.

Contact

Address: 3281 E Guasti Rd
Ontario, CA 91761, United States
Phone: (601) 213-4426
Email: info@benchchem.com

[Contact our Ph.D. Support Team for a compatibility check](#)