

Technical Guide: Optimizing Live-Cell Imaging of DL-9-Anthrylalanine (AnAla)

Author: BenchChem Technical Support Team. **Date:** May 2026

Compound of Interest

Compound Name: DL-9-Anthrylalanine

Cat. No.: B1258518

[Get Quote](#)

Executive Summary: The Photophysics of AnAla

DL-9-Anthrylalanine (AnAla) is a non-canonical amino acid (ncAA) featuring an anthracene side chain. Unlike standard fluorescent proteins (GFP/RFP), AnAla acts as a sensitive environmental probe, often incorporated into proteins via Genetic Code Expansion (GCE) to monitor conformational changes or protein-protein interactions.

However, AnAla presents a unique challenge in live-cell imaging: UV-induced photodegradation. Its excitation maximum (~360–365 nm) falls in the ultraviolet range, triggering two distinct bleaching pathways: [4+4] photocycloaddition (dimerization) and photo-oxidation.

This guide provides a self-validating workflow to minimize these effects while maintaining cell viability.

Critical Troubleshooting Guide (Q&A)

Q1: My signal disappears within seconds of time-lapse imaging. Is this standard oxidation?

Diagnosis: Likely Photodimerization, not just oxidation. Technical Insight: Unlike GFP, which bleaches primarily via Reactive Oxygen Species (ROS), anthracene derivatives undergo a [4+4] photocycloaddition reaction when excited by UV light. This reaction covalently links two anthracene moieties (or an anthracene and a nearby aromatic residue) into a non-fluorescent dimer. This process is often faster than oxidation and is concentration-dependent.

Corrective Protocol:

- Switch to "Tail" Excitation: Instead of hitting the peak excitation at 365 nm, use a 405 nm laser diode.
 - Why: Although 405 nm excites AnAla at only ~10-20% efficiency compared to the peak, it significantly reduces the energy available for the dimerization activation barrier and lowers background autofluorescence from cellular NADH.
- Implement Stroboscopic Illumination: Trigger the laser only during the camera exposure window (e.g., 50 ms) rather than continuous wave (CW) illumination.
- Reduce Fluorophore Density: If AnAla residues are clustered (e.g., in oligomeric proteins), dimerization probability increases exponentially. Lower the expression level by titrating the induction agent (e.g., doxycycline or arabinose).

Q2: The cells show signs of blebbing and apoptosis after 5 minutes of imaging. How do I fix this?

Diagnosis: UV-induced Phototoxicity. Technical Insight: Excitation at 365 nm is highly cytotoxic, causing direct DNA damage and generating intracellular ROS that triggers apoptosis.

Corrective Protocol:

- Hardware Adjustment: Use a high-sensitivity detector (Back-illuminated sCMOS or Hybrid PMT) to allow for drastic reduction in laser power (<1% transmission).
- Media Formulation: Replace standard DMEM/RPMI with a phenol red-free, antioxidant-supplemented medium (e.g., containing Trolox or Ascorbate), but avoid enzymatic oxygen scavengers (like glucose oxidase/catalase) in live cells as they can induce hypoxia and metabolic stress.

Q3: I have high background noise interfering with the AnAla signal.

Diagnosis: Autofluorescence overlap. Technical Insight: AnAla emits in the blue region (~415–450 nm), which overlaps heavily with endogenous fluorophores like NADH and NADPH.

Corrective Protocol:

- **Narrow Bandpass Filtering:** Use a strict emission filter (e.g., 420/20 nm) rather than a wide blue filter (450/50 nm). This cuts out the tail end of NADH emission.
- **Time-Gated Imaging (Advanced):** If using FLIM (Fluorescence Lifetime Imaging), AnAla typically has a distinct lifetime (~4–12 ns depending on environment) compared to cellular autofluorescence (<3 ns). Gating the detector to reject the first few nanoseconds can eliminate background.

Experimental Optimization Data

Table 1: Recommended Acquisition Parameters

Parameter	Standard Setting (Avoid)	Optimized Setting (Recommended)	Rationale
Excitation Source	UV Lamp / 365 nm LED	405 nm Laser Diode	Reduces phototoxicity and dimerization rate; penetrates tissue better.
Laser Power	>10%	0.5% - 2%	Anthracene has a high quantum yield; low power preserves the fluorophore.
Detector	Standard PMT	Hybrid (HyD) or sCMOS	Higher quantum efficiency (>40% in blue) allows lower excitation power.
Emission Filter	450/50 nm (Broad Blue)	417/20 nm or 420/30 nm	Maximizes signal-to-noise by excluding NADH autofluorescence.
Exposure Mode	Continuous	Triggered / Stroboscopic	Eliminates "dark time" bleaching between frames.

Table 2: Comparison of Bleaching Pathways

Pathway	Trigger	Mechanism	Prevention Strategy
Photo-oxidation	Oxygen + Light	Formation of non-fluorescent anthraquinone via singlet oxygen ().	Limit O (difficult in live cells); use antioxidants (Trolox).
Photodimerization	UV Light + Proximity	[4+4] Cycloaddition forming a covalent dimer.	Red-shifted excitation (405 nm); reduce local concentration.

Mechanistic Visualization

The following diagram illustrates the competing pathways AnAla undergoes upon excitation. The goal of the optimization is to maximize the fluorescence pathway while inhibiting dimerization and oxidation.

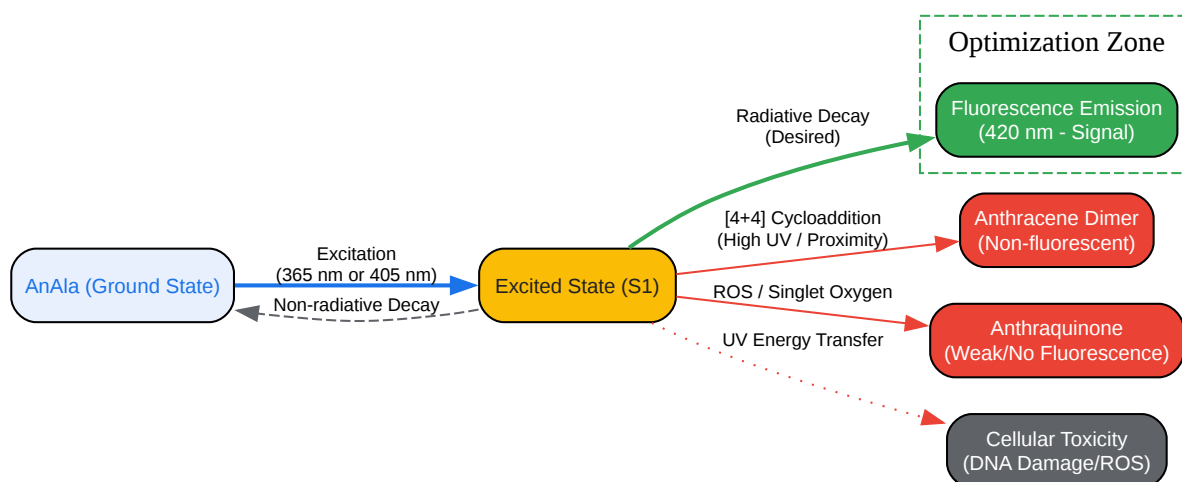

[Click to download full resolution via product page](#)

Caption: Figure 1. Kinetic competition between fluorescence emission and destructive pathways (dimerization/oxidation) in AnAla.

References

- Nikon MicroscopyU. (n.d.). Fluorescence Filter Combinations. Retrieved October 26, 2025, from [\[Link\]](#)
- Chin, J. W. (2014). Expanding and reprogramming the genetic code.[1] *Nature*, 516(7530), 332–343. [\[Link\]](#)
- Bouas-Laurent, H., et al. (2001). Photodimerization of anthracenes in fluid solutions: (part 2) mechanistic aspects. *Chemical Society Reviews*, 30, 248-263. [\[Link\]](#)
- Specht, E. A., et al. (2017). Efficient Genetic Encoding of a Photostable, Blue-Emitting Fluorophore. *Journal of the American Chemical Society*, 139(36), 12610–12616. (Note: Discusses Acridonylalanine as a more stable alternative to Anthrylalanine). [\[Link\]](#)

Need Custom Synthesis?

BenchChem offers custom synthesis for rare earth carbides and specific isotopic labeling.

Email: info@benchchem.com or [Request Quote Online](#).

Sources

- 1. [researchgate.net](https://www.researchgate.net) [[researchgate.net](https://www.researchgate.net)]
- To cite this document: BenchChem. [Technical Guide: Optimizing Live-Cell Imaging of DL-9-Anthrylalanine (AnAla)]. BenchChem, [2026]. [Online PDF]. Available at: [\[https://www.benchchem.com/product/b1258518/docs#technical-guide-optimizing-live-cell-imaging-of-dl-9-anthrylalanine-anala\]](https://www.benchchem.com/product/b1258518/docs#technical-guide-optimizing-live-cell-imaging-of-dl-9-anthrylalanine-anala)

Disclaimer & Data Validity:

The information provided in this document is for Research Use Only (RUO) and is strictly not intended for diagnostic or therapeutic procedures. While BenchChem strives to provide

accurate protocols, we make no warranties, express or implied, regarding the fitness of this product for every specific experimental setup.

Technical Support: The protocols provided are for reference purposes. Unsure if this reagent suits your experiment?

Need Industrial/Bulk Grade? [Request Custom Synthesis Quote](#)

BenchChem

Our mission is to be the trusted global source of essential and advanced chemicals, empowering scientists and researchers to drive progress in science and industry.

Contact

Address: 3281 E Guasti Rd

Ontario, CA 91761, United States

Phone: (601) 213-4426

Email: info@benchchem.com

[Contact our Ph.D. Support Team for a compatibility check](#)