

# Comparative Guide: Cross-Validation of 5-Ethynylcytidine (5-EC) Labeling

**Author:** BenchChem Technical Support Team. **Date:** April 2026

## Compound of Interest

Compound Name: 5-Ethynylcytidine

Cat. No.: B1258090

[Get Quote](#)

## Executive Summary: Why Validate 5-EC?

**5-Ethynylcytidine (5-EC)** is a powerful ribonucleoside analog for metabolic labeling of nascent RNA.<sup>[1]</sup> Unlike the widely used 5-Ethynyluridine (5-EU), 5-EC targets cytidine metabolism, offering a distinct incorporation profile that is critical for studying GC-rich transcripts and verifying RNA synthesis kinetics independent of uridine pathways.

However, metabolic labeling is not artifact-free. The conversion of ribonucleosides to deoxyribonucleosides by Ribonucleotide Reductase (RNR) can lead to unintended DNA labeling, and high concentrations may induce cytotoxicity. This guide provides a rigorous, orthogonal framework to cross-validate 5-EC data against established gold standards (BrU, qRT-PCR) and alternative analogs (5-EU), ensuring your data reflects true transcriptional activity.

## The Validation Matrix: 5-EC vs. Orthogonal Methods

### Comparison 1: 5-EC vs. 5-Ethynyluridine (5-EU)

While both analogs utilize Copper(I)-catalyzed Azide-Alkyne Cycloaddition (CuAAC) for detection, they track different metabolic pools.

Feature	5-Ethynylcytidine (5-EC)	5-Ethynyluridine (5-EU)	Expert Insight / Causality
Metabolic Pathway	Salvage pathway via Uridine-Cytidine Kinase (UCK2)	Salvage pathway via Uridine-Cytidine Kinase (UCK2) or UPRT	Validation: 5-EC is preferred in cell lines with differential kinase expression or when uridine metabolism is perturbed.
Incorporation Rate	High; often faster metabolism in specific tissues (e.g., liver, kidney).	High; standard for general transcription.	Causality: Qu et al. (2013) demonstrated 5-EC can have superior kinetics in murine models due to distinct transporter affinities.
GC-Bias	Biased toward GC-rich regions.	Biased toward AU-rich regions.	Application: Use 5-EC to cross-validate 5-EU data. If a transcript is visible with 5-EU but absent with 5-EC, consider sequence bias or metabolic block.
Toxicity	Generally low in short pulses (<4h).	Known inhibition of rRNA synthesis at high conc./long exposure.	Protocol: Always perform a viability curve (ATP/MTT assay) for your specific cell line.

## Comparison 2: 5-EC vs. Bromouridine (BrU)

BrU is the historical immunocytochemical standard.

- Sensitivity: 5-EC (Click) > BrU (Antibody). Click chemistry has a 1:1 fluorophore-to-analog ratio and superior tissue penetration compared to bulky antibodies required for BrU.

- Workflow: 5-EC allows whole-mount staining (e.g., organoids, thick tissue) where anti-BrdU antibodies fail to penetrate.
- Validation: If 5-EC signal localization (nucleolus vs. nucleoplasm) matches BrU patterns under Actinomycin D treatment, the spatial specificity is confirmed.

## Critical Mechanism: The Metabolic Fork in the Road

Understanding how 5-EC is incorporated is the first step in validation. The risk of "off-target" DNA labeling exists if 5-EC is reduced to 5-EdC (5-Ethynyl-2'-deoxycytidine).

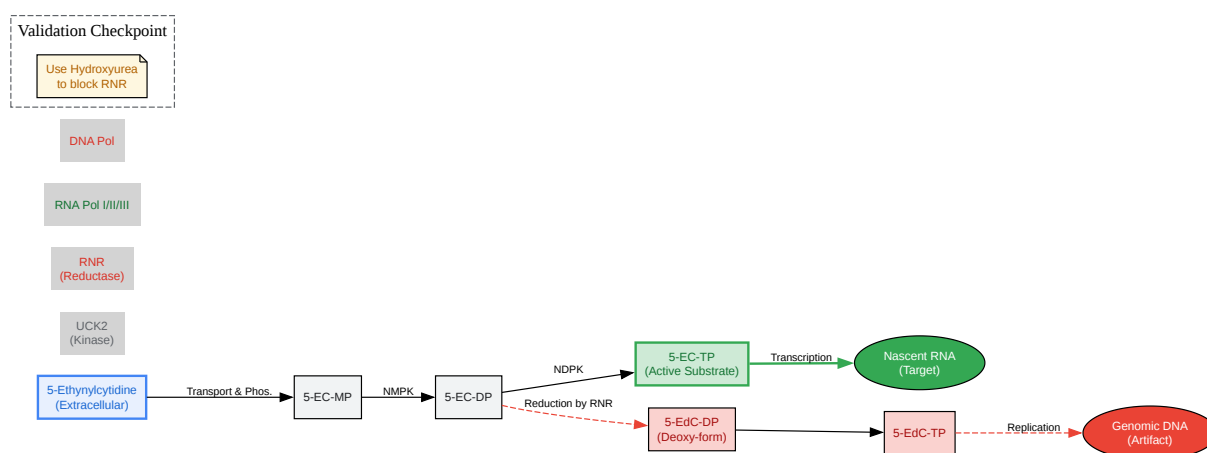

[Click to download full resolution via product page](#)

Figure 1: Metabolic fate of **5-Ethynylcytidine**. The critical validation step is blocking the RNR pathway to ensure signal is exclusively RNA.

# Self-Validating Experimental Protocols

## Protocol A: The "Specificity Triad" (Microscopy)

Objective: Prove the fluorescent signal is RNA-dependent and Transcription-dependent.

Materials:

- **5-Ethynylcytidine** (1 mM stock in DMSO)
- Actinomycin D (ActD) (Transcription Inhibitor)
- RNase A (Post-fixation digest)
- Hydroxyurea (HU) (Optional: RNR inhibitor for S-phase cells)

Workflow:

- Seed Cells: HeLa or NIH3T3 on coverslips.
- Condition Setup:
  - Control: 5-EC (1 mM) for 1 hour.
  - Negative Control 1 (Synthesis Block): Pre-treat with ActD (5  $\mu\text{g}/\text{mL}$ ) for 30 min, then co-incubate with 5-EC.
  - Negative Control 2 (Substrate Digest): 5-EC labeling -> Fixation -> RNase A digestion (100  $\mu\text{g}/\text{mL}$ , 30 min at 37°C) -> Click Reaction.
- Labeling: Incubate Control and ActD samples with 1 mM 5-EC for 1 hour at 37°C.
- Fixation: 4% Paraformaldehyde (15 min). Permeabilize with 0.5% Triton X-100.
- Click Reaction:
  - Reaction Buffer: 100 mM Tris (pH 8.5), 1 mM  $\text{CuSO}_4$ , 10  $\mu\text{M}$  Fluorescent Azide (e.g., Azide-488), 100 mM Ascorbic Acid (Fresh!).

- Stain for 30 min in dark.[2]
- Imaging:
  - Valid Result: Control shows strong nucleolar/nucleoplasmic signal. ActD sample is dark.[2] RNase sample is dark.[2][3]
  - Invalid Result: Signal persists in RNase sample (indicates DNA incorporation or non-specific sticking).

## Protocol B: Quantitative Cross-Validation (Click-IP-qPCR)

Objective: Correlate 5-EC incorporation with transcript abundance measured by qRT-PCR.

Concept: Instead of a fluorophore, use Biotin-Azide.[4] Pull down the labeled RNA and quantify specific transcripts.[5][6]

- Pulse: Treat cells with 5-EC (0.5 mM) for 2 hours.
- Extract: Isolate Total RNA (Trizol or column).
- Click: Perform Click reaction in solution using Biotin-Azide (NOT fluorescent).
  - Note: Precipitate RNA after Click to remove unreacted Biotin.
- Pull-down: Incubate RNA with Streptavidin-Magnetic Beads.
  - Wash stringent (high salt) to remove non-specific binders.
- Elute & RT-qPCR:
  - Elute RNA (95°C in formamide or direct RT on beads).
  - Perform qPCR for a housekeeping gene (GAPDH) and a short-lived transcript (c-MYC).
- Calculation:

- Calculate Enrichment Ratio =  $(Ct\_Input - Ct\_Pulldown)$  of 5-EC sample vs.  $(Ct\_Input - Ct\_Pulldown)$  of Non-Click Control.
- Success Criteria: >10-fold enrichment of newly synthesized transcripts (c-MYC) over stable pools.

## Decision Framework: When to use 5-EC?

Use the following logic flow to determine if 5-EC is the correct tool for your experimental context.

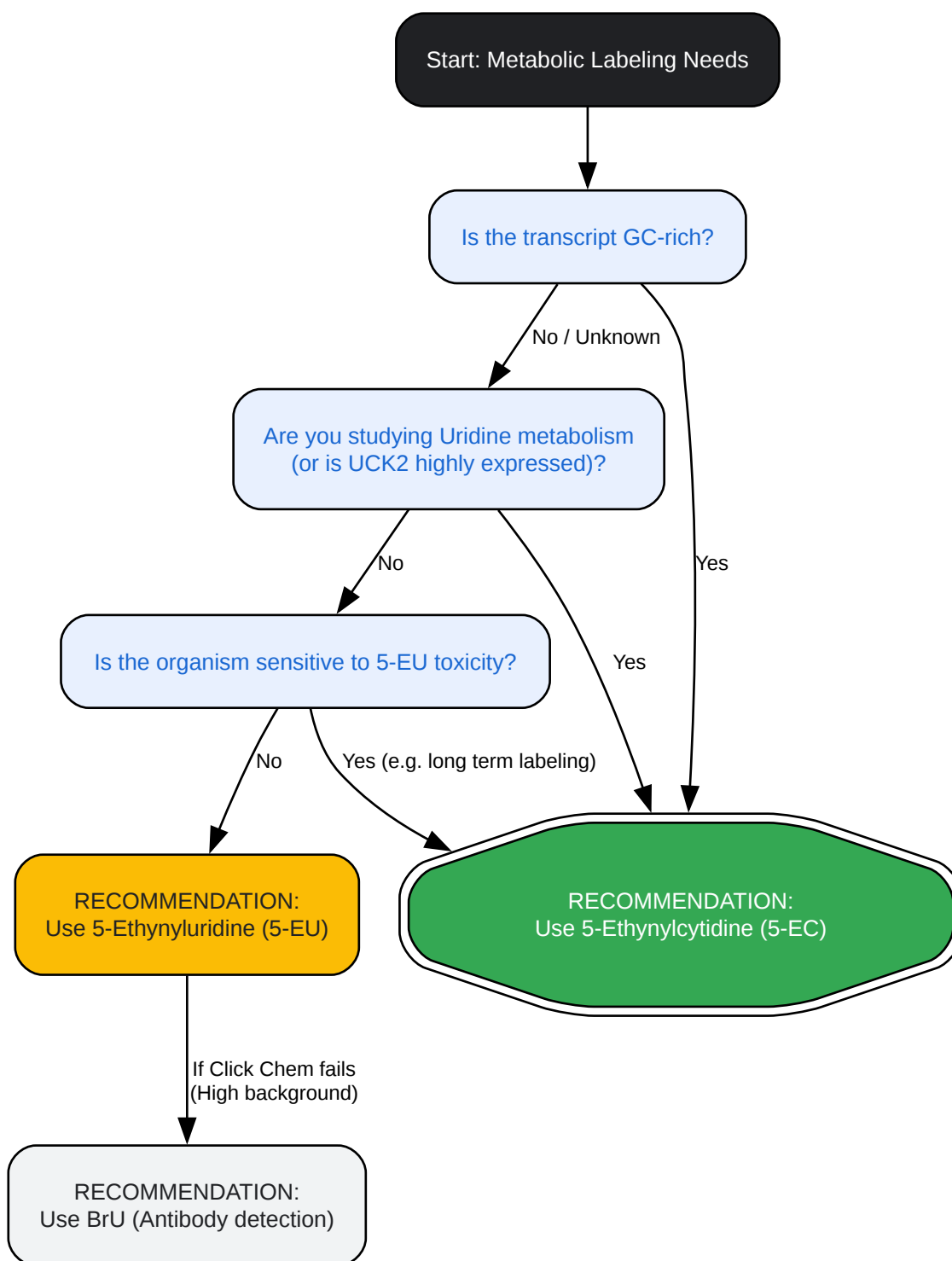

[Click to download full resolution via product page](#)

Figure 2: Selection logic for choosing 5-EC over orthogonal nucleoside analogs.

## References

- Qu, J., et al. (2013). "**5-Ethynylcytidine** as a new agent for detecting RNA synthesis in live cells by click chemistry." [4][7] *Analytical Biochemistry*, 434(1), 128-135. [Link](#)
  - Core reference for 5-EC synthesis, specificity, and comparison to BrU.
- Jao, C. Y., & Salic, A. (2008). "Exploring RNA transcription and turnover in vivo by using click chemistry." *Proceedings of the National Academy of Sciences*, 105(41), 15779-15784. [Link](#)
  - Foundational paper for metabolic labeling with ethynyl-nucleosides (5-EU).
- Tani, H., et al. (2012). "Genome-wide determination of RNA stability reveals hundreds of short-lived non-coding transcripts in mammals." *Genome Research*, 22(5), 947-956. [Link](#)
  - Reference for BrU-IP and pulse-chase methodologies.
- Neef, A. B., & Luedtke, N. W. (2011). "Dynamic metabolic labeling of DNA in vivo with arabinosyl nucleosides." *Proceedings of the National Academy of Sciences*, 108(51), 20404-20409. [Link](#)
  - Provides context on RNR-mediated conversion of nucleosides and specificity challenges.

### Need Custom Synthesis?

BenchChem offers custom synthesis for rare earth carbides and specific isotopic labeling.

Email: [info@benchchem.com](mailto:info@benchchem.com) or [Request Quote Online](#).

## Sources

- 1. The nascent RNA labelling compound 5-ethynyl uridine (EU) integrates into DNA in some animals - PMC [[pmc.ncbi.nlm.nih.gov](https://pubmed.ncbi.nlm.nih.gov/)]
- 2. [researchgate.net](https://www.researchgate.net/) [[researchgate.net](https://www.researchgate.net/)]
- 3. Expanding the Scope of RNA Metabolic Labeling with Vinyl Nucleosides and Inverse Electron-Demand Diels-Alder Chemistry - PMC [[pmc.ncbi.nlm.nih.gov](https://pubmed.ncbi.nlm.nih.gov/)]
- 4. 5-Ethynyl-cytidine (5-EC), RNA synthesis monitoring - Jena Bioscience [[jenabioscience.com](https://www.jenabioscience.com/)]

- [5. Metabolic labeling of RNA using multiple ribonucleoside analogs enables simultaneous evaluation of transcription and degradation rates | bioRxiv \[biorxiv.org\]](#)
- [6. Investigation of RNA Synthesis Using 5-Bromouridine Labelling and Immunoprecipitation - PMC \[pmc.ncbi.nlm.nih.gov\]](#)
- [7. jenabioscience.com \[jenabioscience.com\]](#)
- To cite this document: BenchChem. [Comparative Guide: Cross-Validation of 5-Ethynylcytidine (5-EC) Labeling]. BenchChem, [2026]. [Online PDF]. Available at: [<https://www.benchchem.com/product/b1258090/docs#comparative-guide-cross-validation-of-5-ethynylcytidine-5-ec-labeling>]

---

### Disclaimer & Data Validity:

The information provided in this document is for Research Use Only (RUO) and is strictly not intended for diagnostic or therapeutic procedures. While BenchChem strives to provide accurate protocols, we make no warranties, express or implied, regarding the fitness of this product for every specific experimental setup.

**Technical Support:** The protocols provided are for reference purposes. Unsure if this reagent suits your experiment?

**Need Industrial/Bulk Grade?** [Request Custom Synthesis Quote](#)

## BenchChem

Our mission is to be the trusted global source of essential and advanced chemicals, empowering scientists and researchers to drive progress in science and industry.

### Contact

Address: 3281 E Guasti Rd  
Ontario, CA 91761, United States  
Phone: (601) 213-4426  
Email: [info@benchchem.com](mailto:info@benchchem.com)

Contact our Ph.D. Support Team for a compatibility check