

Application Notes and Protocols: Using N-Desmethylclomipramine in Competitive Binding Assays

Author: BenchChem Technical Support Team. **Date:** April 2026

Compound of Interest

Compound Name: *N-Desmethyl clomipramine*

CAS No.: 29854-14-6

Cat. No.: B1258145

[Get Quote](#)

For Researchers, Scientists, and Drug Development Professionals

Introduction

N-desmethylclomipramine, also known as norclomipramine, is the primary and pharmacologically active metabolite of the tricyclic antidepressant clomipramine. It plays a significant role in the therapeutic effects of its parent compound by inhibiting the reuptake of monoamine neurotransmitters. Notably, N-desmethylclomipramine exhibits a distinct pharmacological profile, with a higher potency for the norepinephrine transporter (NET) and dopamine transporter (DAT) compared to clomipramine, while being a less potent inhibitor of the serotonin transporter (SERT).[1] This differential activity makes N-desmethylclomipramine a valuable tool in neuroscience research and drug development for dissecting the roles of individual monoamine transporters and for the characterization of novel psychoactive compounds.

These application notes provide detailed protocols for utilizing N-desmethylclomipramine in competitive binding assays to determine the affinity of test compounds for the serotonin and

norepinephrine transporters.

Pharmacological Profile of N-Desmethylclomipramine

N-desmethylclomipramine's primary mechanism of action is the blockade of monoamine reuptake by binding to their respective transporters. This inhibition leads to an increased concentration of neurotransmitters in the synaptic cleft, thereby enhancing neurotransmission. Its binding affinity is highest for the norepinephrine transporter, followed by the serotonin transporter. While it is a more potent inhibitor of dopamine uptake than its parent compound, clomipramine, its affinity for the dopamine transporter is generally lower than for SERT and NET.[1]

Quantitative Data: Binding Affinities of N-Desmethylclomipramine

The following table summarizes the in vitro binding affinities (K_i) of N-desmethylclomipramine for the human serotonin and norepinephrine transporters. Lower K_i values indicate a higher binding affinity.

Compound	Target Transporter	K_i (nM)
N-Desmethylclomipramine	Serotonin Transporter (SERT)	1.8
Norepinephrine Transporter (NET)		0.4
Dopamine Transporter (DAT)	Less potent inhibitor; specific K_i values are not consistently reported but are significantly higher than for SERT and NET.	

Note: K_i values can vary between studies depending on the experimental conditions, such as radioligand used, tissue source, and buffer composition.

Experimental Protocols

Protocol 1: Competitive Radioligand Binding Assay for the Serotonin Transporter (SERT)

This protocol is designed to determine the binding affinity of a test compound for the human serotonin transporter using N-desmethylclomipramine as a reference compound. The assay is based on the competition between the unlabeled test compound and a radiolabeled ligand for binding to SERT.

Materials and Reagents:

- Membrane Preparation: Human platelet membranes or cell membranes from a cell line stably expressing the human SERT.
- Radioligand: [³H]Citalopram (specific activity ~70-90 Ci/mmol).
- Reference Compound: N-Desmethylclomipramine hydrochloride.
- Test Compound.
- Assay Buffer: 50 mM Tris-HCl, 120 mM NaCl, 5 mM KCl, pH 7.4.
- Wash Buffer: Ice-cold 50 mM Tris-HCl, pH 7.4.
- Non-specific Binding Determinator: 10 μM Fluoxetine.
- 96-well microplates.
- Glass fiber filters (e.g., Whatman GF/B).
- Scintillation cocktail.
- Scintillation counter.
- Filtration apparatus.

Procedure:

- Preparation of Reagents:

- Prepare serial dilutions of the test compound and N-desmethylclomipramine in assay buffer. A typical concentration range would be from 10^{-11} M to 10^{-5} M.
- Dilute the [3 H]Citalopram in assay buffer to a final concentration of ~ 1 nM.
- Thaw the membrane preparation on ice and dilute to a final protein concentration of 5-10 μ g/well in assay buffer.
- Assay Setup (in triplicate):
 - Total Binding: Add 50 μ L of assay buffer, 50 μ L of [3 H]Citalopram solution, and 100 μ L of membrane preparation to designated wells.
 - Non-specific Binding (NSB): Add 50 μ L of 10 μ M Fluoxetine, 50 μ L of [3 H]Citalopram solution, and 100 μ L of membrane preparation to designated wells.
 - Test Compound/Reference Compound: Add 50 μ L of each dilution of the test compound or N-desmethylclomipramine, 50 μ L of [3 H]Citalopram solution, and 100 μ L of membrane preparation to the remaining wells.
- Incubation: Incubate the plate at room temperature (22-25°C) for 60 minutes with gentle agitation.
- Filtration: Rapidly filter the contents of each well through the glass fiber filters using a cell harvester. Wash the filters three times with 3 mL of ice-cold wash buffer to remove unbound radioligand.
- Scintillation Counting:
 - Place the filters in scintillation vials.
 - Add 4-5 mL of scintillation cocktail to each vial.
 - Allow the vials to equilibrate in the dark for at least 4 hours.
 - Measure the radioactivity in counts per minute (CPM) using a scintillation counter.
- Data Analysis:

- Calculate the specific binding: Specific Binding = Total Binding (CPM) - Non-specific Binding (CPM).
- Plot the percentage of specific binding against the logarithm of the competitor concentration.
- Determine the IC₅₀ value (the concentration of the competitor that inhibits 50% of the specific binding of the radioligand) using non-linear regression analysis (sigmoidal dose-response curve).
- Calculate the inhibition constant (K_i) using the Cheng-Prusoff equation: $K_i = IC_{50} / (1 + ([L]/K_d))$
 - Where [L] is the concentration of the radioligand used and K_d is the dissociation constant of the radioligand for the receptor.

Protocol 2: Competitive Radioligand Binding Assay for the Norepinephrine Transporter (NET)

This protocol outlines the procedure for determining the binding affinity of a test compound for the human norepinephrine transporter.

Materials and Reagents:

- Membrane Preparation: Rat cortical membranes or cell membranes from a cell line stably expressing the human NET.
- Radioligand: [³H]Nisoxetine (specific activity ~70-90 Ci/mmol).
- Reference Compound: N-Desmethyldesipramine hydrochloride.
- Test Compound.
- Assay Buffer: 50 mM Tris-HCl, 300 mM NaCl, 5 mM KCl, pH 7.4.
- Wash Buffer: Ice-cold 50 mM Tris-HCl, pH 7.4.
- Non-specific Binding Determinator: 10 μM Desipramine.

- 96-well microplates.
- Glass fiber filters (e.g., Whatman GF/B).
- Scintillation cocktail.
- Scintillation counter.
- Filtration apparatus.

Procedure:

- Preparation of Reagents:
 - Prepare serial dilutions of the test compound and N-desmethyldesipramine in assay buffer.
 - Dilute the [³H]Nisoxetine in assay buffer to a final concentration of ~1-2 nM.
 - Thaw the membrane preparation on ice and dilute to a final protein concentration of 100-200 μg/well in assay buffer.
- Assay Setup (in triplicate):
 - Total Binding: Add 50 μL of assay buffer, 50 μL of [³H]Nisoxetine solution, and 100 μL of membrane preparation.
 - Non-specific Binding (NSB): Add 50 μL of 10 μM Desipramine, 50 μL of [³H]Nisoxetine solution, and 100 μL of membrane preparation.
 - Test Compound/Reference Compound: Add 50 μL of each dilution of the test compound or N-desmethyldesipramine, 50 μL of [³H]Nisoxetine solution, and 100 μL of membrane preparation.
- Incubation: Incubate the plate at 4°C for 2-3 hours.
- Filtration: Rapidly filter the contents of each well through the glass fiber filters and wash three times with ice-cold wash buffer.

- Scintillation Counting: Perform scintillation counting as described in Protocol 1.
- Data Analysis: Analyze the data as described in Protocol 1 to determine the IC_{50} and K_i values.

Visualizations

Signaling Pathway Diagrams

The following diagrams illustrate the mechanism of action of the serotonin and norepinephrine transporters and the inhibitory effect of N-desmethylclomipramine.

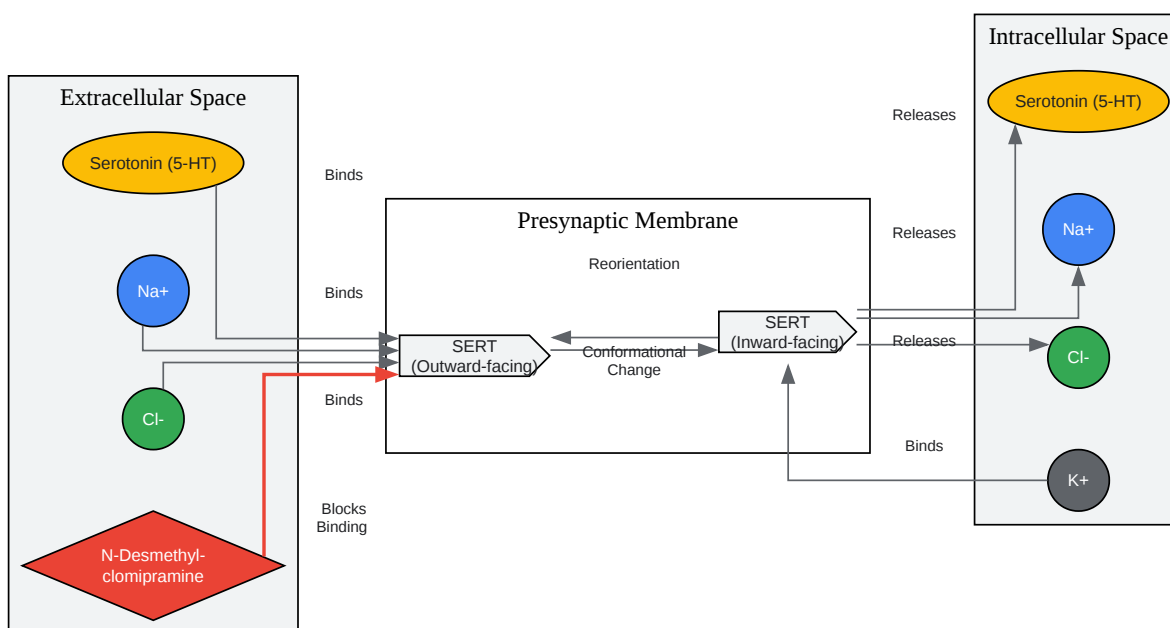

[Click to download full resolution via product page](#)

Caption: Mechanism of Serotonin Transporter (SERT) and inhibition by N-desmethylclomipramine.

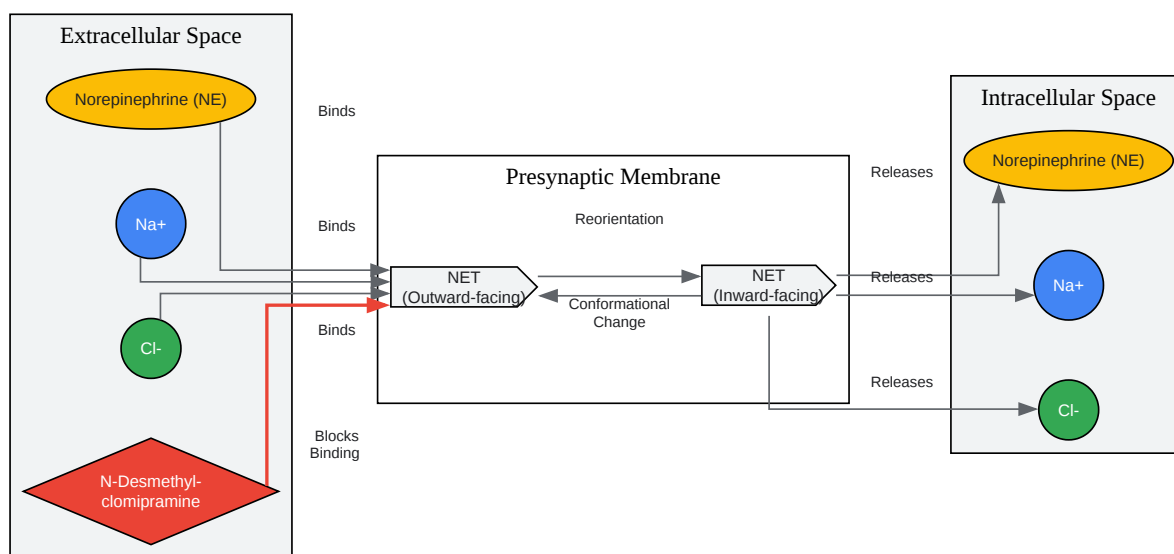

[Click to download full resolution via product page](#)

Caption: Mechanism of Norepinephrine Transporter (NET) and inhibition by N-desmethylclomipramine.

Experimental Workflow Diagram

The following diagram illustrates the general workflow for a competitive radioligand binding assay.

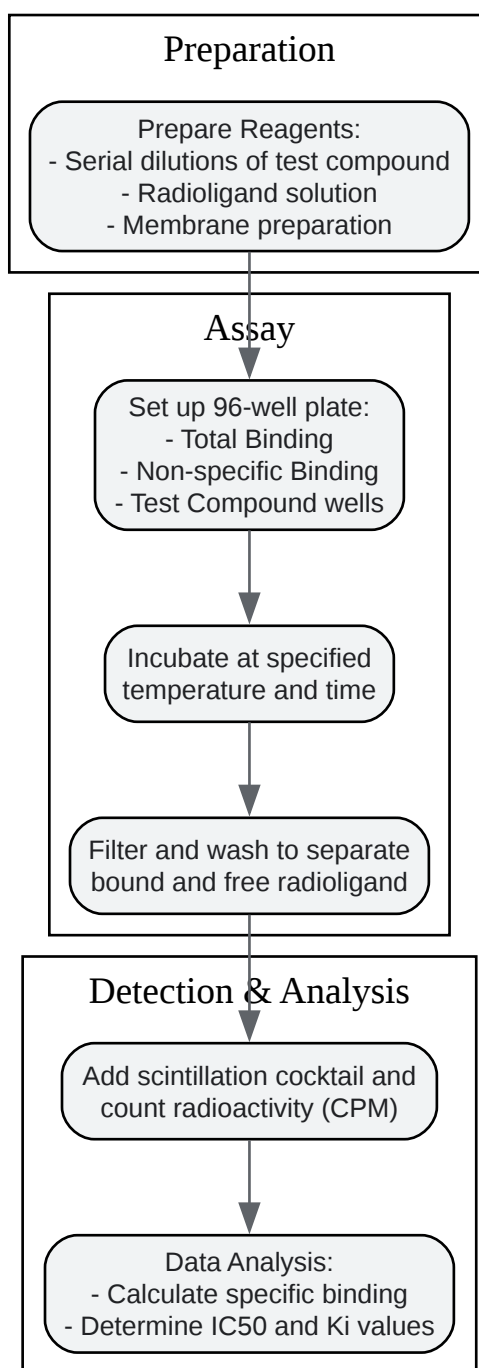

[Click to download full resolution via product page](#)

Caption: General workflow for a competitive radioligand binding assay.

Need Custom Synthesis?

BenchChem offers custom synthesis for rare earth carbides and specific isotopic labeling.

Email: info@benchchem.com or [Request Quote Online](#).

References

- 1. Some pharmacological aspects of desmethylclomipramine - PubMed [pubmed.ncbi.nlm.nih.gov]
- To cite this document: BenchChem. [Application Notes and Protocols: Using N-Desmethylclomipramine in Competitive Binding Assays]. BenchChem, [2026]. [Online PDF]. Available at: [<https://www.benchchem.com/product/b1258145/docs#application-notes-and-protocols-using-n-desmethylclomipramine-in-competitive-binding-assays>]

Disclaimer & Data Validity:

The information provided in this document is for Research Use Only (RUO) and is strictly not intended for diagnostic or therapeutic procedures. While BenchChem strives to provide accurate protocols, we make no warranties, express or implied, regarding the fitness of this product for every specific experimental setup.

Technical Support: The protocols provided are for reference purposes. Unsure if this reagent suits your experiment?

Need Industrial/Bulk Grade? [Request Custom Synthesis Quote](#)

BenchChem

Our mission is to be the trusted global source of essential and advanced chemicals, empowering scientists and researchers to drive progress in science and industry.

Contact

Address: 3281 E Guasti Rd
Ontario, CA 91761, United States
Phone: (601) 213-4426
Email: info@benchchem.com

Contact our Ph.D. Support Team for a compatibility check