

Unraveling the Enigma of Fragilin: A Look into Potential Signaling Pathway Interactions

Author: BenchChem Technical Support Team. **Date:** December 2025

Compound of Interest

Compound Name: *Fragilin*

Cat. No.: *B1257426*

[Get Quote](#)

For researchers, scientists, and professionals in drug development, understanding the precise mechanism of action of a compound is paramount. While the anthraquinone derivative **Fragilin** has been identified, a comprehensive validation of its effect on a specific signaling pathway remains elusive in current scientific literature. This guide provides an objective overview of the known biological activities of the broader anthraquinone class, offering insights into the potential, yet unconfirmed, signaling pathways that **Fragilin** may influence.

Initial investigations into the biological activity of **Fragilin**, and its chemical synonym 2-Chlorophyscion, did not yield specific studies detailing its impact on any particular signaling pathway. PubChem identifies **Fragilin** as an anthraquinone, but literature specifically validating its mechanism of action is not currently available.[1]

However, the broader class of anthraquinone derivatives has been the subject of various studies, revealing their potential to modulate several key cellular signaling pathways. This information can serve as a foundational guide for future research into **Fragilin**'s specific effects.

Potential Signaling Pathways Modulated by Anthraquinone Derivatives

Based on studies of various anthraquinone compounds, the following signaling pathways have been identified as potential targets. It is important to note that these are general activities of the

chemical class, and specific effects of **Fragilin** would require dedicated experimental validation.

Signaling Pathway	Observed Effect of Anthraquinone Derivatives	Potential Implication	Reference
c-Met Kinase Signaling Pathway	Inhibition of c-Met kinase activity and suppression of HGF-stimulated c-Met phosphorylation.	Potential as an anticancer agent by blocking tumor cell growth, migration, and invasion.	[2]
ROS/JNK Signaling Pathway	Induction of apoptosis in cancer cells through the generation of reactive oxygen species (ROS) and activation of the JNK pathway.	Could be explored for its pro-apoptotic effects in oncology research.	[3]
Nrf2/HO-1 Signaling Pathway	At low concentrations, some anthraquinones can induce a protective hormetic effect by activating the Nrf2/HO-1 pathway, which is involved in the cellular stress response.	May have applications in cytoprotection and neuroprotection under specific conditions.	[4]

Visualizing Potential Anthraquinone-Modulated Pathways

To illustrate the potential mechanisms of action based on the broader anthraquinone class, the following diagrams depict the signaling cascades that could theoretically be influenced by **Fragilin**.

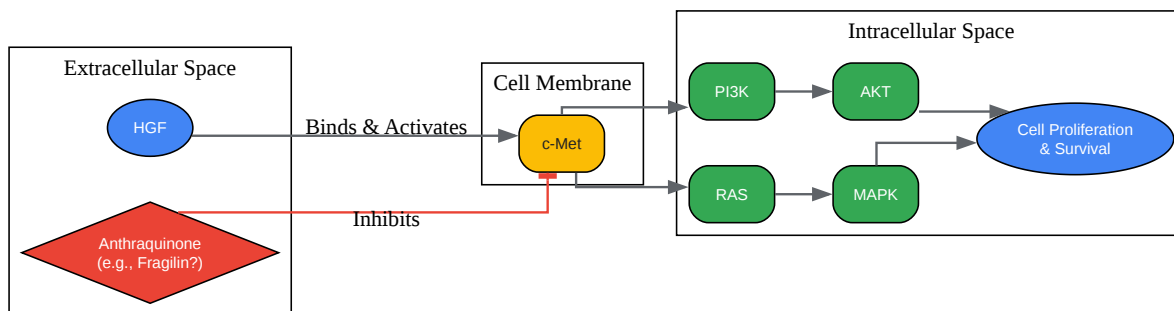

[Click to download full resolution via product page](#)

Potential inhibition of the c-Met signaling pathway by an anthraquinone.

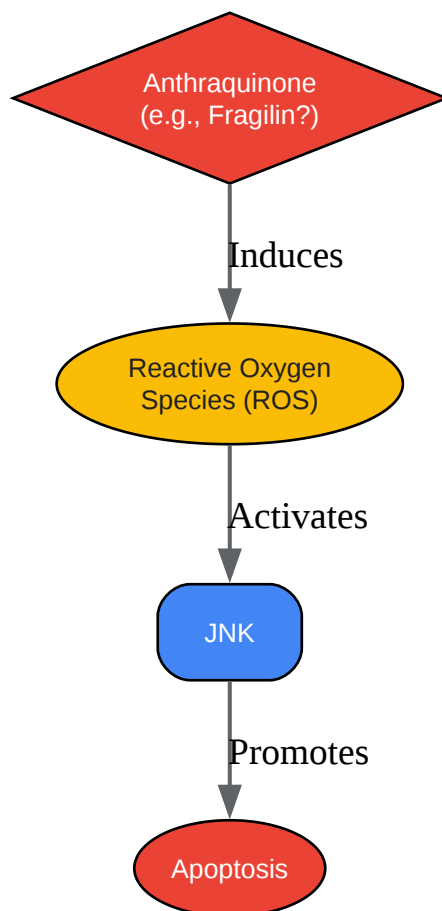

[Click to download full resolution via product page](#)

Induction of apoptosis via the ROS/JNK pathway by an anthraquinone.

Experimental Protocols: A General Framework

For researchers aiming to validate the effect of **Fragilin** on these or other signaling pathways, a general experimental workflow is proposed. Specific details would need to be optimized for the cell lines and assays used.

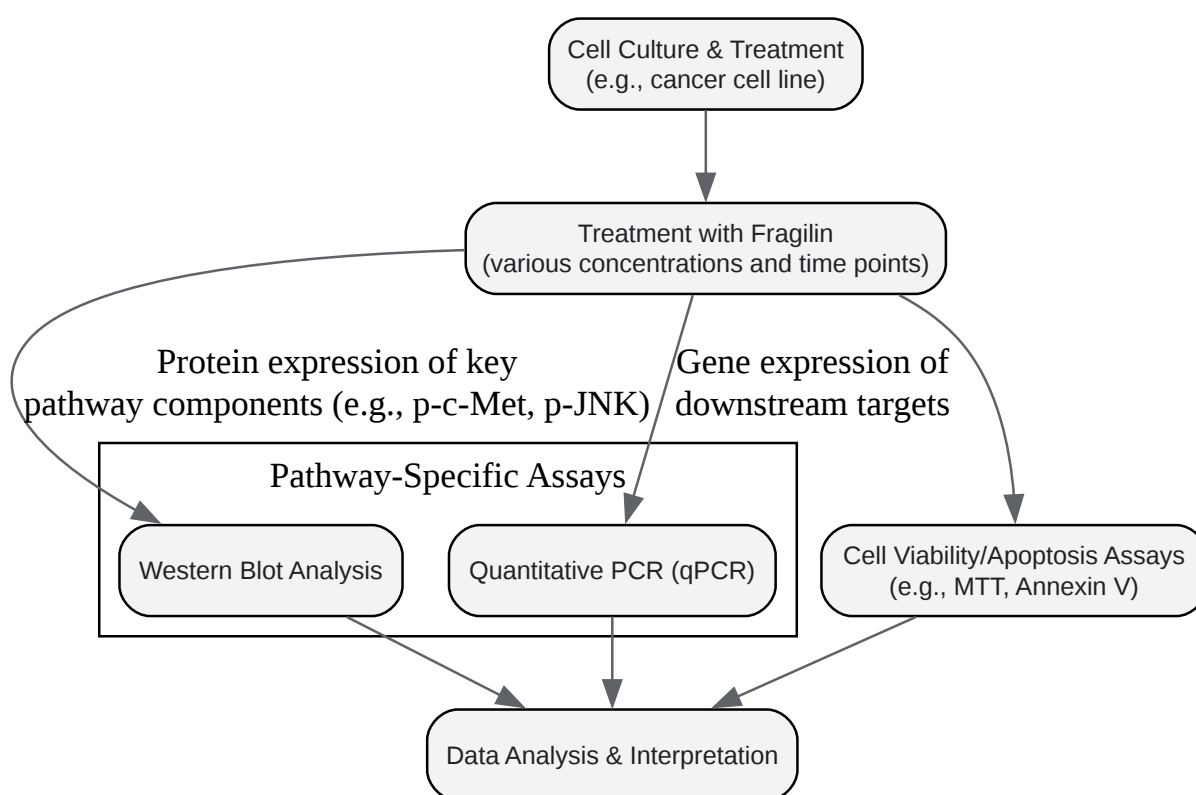

[Click to download full resolution via product page](#)

A general experimental workflow for validating **Fragilin's** effects.

Key Experimental Methodologies:

- Cell Culture and Treatment: Specific cell lines relevant to the signaling pathway of interest (e.g., A549 for c-Met, HCT116 for ROS/JNK) should be cultured under standard conditions. [2][3] Cells would then be treated with a range of concentrations of **Fragilin** for various time points.

- **Western Blot Analysis:** This technique is crucial for observing changes in the phosphorylation status and total protein levels of key signaling molecules within a pathway. For instance, to study the c-Met pathway, antibodies against total c-Met and phosphorylated c-Met would be used.[2]
- **Quantitative PCR (qPCR):** To assess the transcriptional effects of **Fragilin**, qPCR can be used to measure the mRNA levels of downstream target genes of the signaling pathway.
- **Cell Viability and Apoptosis Assays:** Assays such as MTT or WST-1 can be used to determine the effect of **Fragilin** on cell proliferation. To investigate apoptosis, techniques like Annexin V/Propidium Iodide staining followed by flow cytometry are standard.
- **ROS Detection:** To investigate the involvement of reactive oxygen species, cellular ROS levels can be measured using fluorescent probes like DCFH-DA.

Conclusion and Future Directions

While the specific effects of **Fragilin** on a defined signaling pathway are yet to be elucidated, the known activities of the broader anthraquinone class provide a valuable starting point for future research. The signaling pathways of c-Met, ROS/JNK, and Nrf2/HO-1 represent plausible, yet unconfirmed, targets. The experimental frameworks outlined in this guide offer a roadmap for researchers to systematically investigate and validate the precise mechanism of action of **Fragilin**. Such studies are essential to unlock its potential therapeutic applications.

Need Custom Synthesis?

BenchChem offers custom synthesis for rare earth carbides and specific isotopic labeling.

Email: info@benchchem.com or [Request Quote Online](#).

References

- 1. Fragilin | C16H11ClO5 | CID 15559331 - PubChem [pubchem.ncbi.nlm.nih.gov]
- 2. Anthraquinone Derivatives as Potent Inhibitors of c-Met Kinase and the Extracellular Signaling Pathway - PMC [pmc.ncbi.nlm.nih.gov]
- 3. mdpi.com [mdpi.com]

- 4. Anthraquinone derivative exerted hormetic effect on the apoptosis in oxygen-glucose deprivation-induced PC12 cells via ERK and Akt activated Nrf2/HO-1 signaling pathway - PubMed [pubmed.ncbi.nlm.nih.gov]
- To cite this document: BenchChem. [Unraveling the Enigma of Fragilin: A Look into Potential Signaling Pathway Interactions]. BenchChem, [2025]. [Online PDF]. Available at: [https://www.benchchem.com/product/b1257426#validation-of-fragilin-s-effect-on-a-specific-signaling-pathway]

Disclaimer & Data Validity:

The information provided in this document is for Research Use Only (RUO) and is strictly not intended for diagnostic or therapeutic procedures. While BenchChem strives to provide accurate protocols, we make no warranties, express or implied, regarding the fitness of this product for every specific experimental setup.

Technical Support: The protocols provided are for reference purposes. Unsure if this reagent suits your experiment? [[Contact our Ph.D. Support Team for a compatibility check](#)]

Need Industrial/Bulk Grade? [Request Custom Synthesis Quote](#)

BenchChem

Our mission is to be the trusted global source of essential and advanced chemicals, empowering scientists and researchers to drive progress in science and industry.

Contact

Address: 3281 E Guasti Rd
Ontario, CA 91761, United States
Phone: (601) 213-4426
Email: info@benchchem.com