

Application Notes and Protocols for Aniline in Aqueous Synthetic Systems

Author: BenchChem Technical Support Team. **Date:** May 2026

Compound of Interest

Compound Name: *Aniline water*

CAS No.: *179938-55-7*

Cat. No.: *B12563989*

[Get Quote](#)

For Researchers, Scientists, and Drug Development Professionals

The following application notes detail the use of aqueous systems for organic synthesis involving aniline, either as a reactant or as a product. Employing water as a solvent aligns with the principles of green chemistry, offering benefits such as reduced cost, enhanced safety, and lower environmental impact. These protocols provide detailed methodologies for a range of transformations, including condensation reactions, C-C bond formation, reductions, and electrophilic substitutions.

Application Note 1: Non-Catalytic Condensation of Aromatic Aldehydes with Aniline in High-Temperature Water

Introduction: The synthesis of diaminotriphenylmethanes is a crucial step in the production of dyes and other functional materials. Traditionally, this condensation reaction requires strong acid catalysts. However, utilizing high-temperature water, particularly near its critical point (near-critical water, NCW), can facilitate this reaction without the need for an external catalyst.

[1][2] High-temperature water acts as both a solvent and a catalyst, as its ion product increases, providing a source of protons to promote the reaction.[2]

Data Presentation:

The following table summarizes the results for the non-catalytic condensation of various aromatic aldehydes with aniline in high-temperature water.

Entry	Aldehyde Substituent (X)	Temperature (°C)	Time (min)	Water Density (g/cm ³)	Yield (%)
1	4-Cl	350	3	0.15	95
2	4-Br	350	3	0.15	96
3	4-H	350	3	0.15	93
4	4-NO ₂	350	3	0.15	91
5	4-OCH ₃	350	3	0.15	89

Experimental Protocol:

Materials:

- Aromatic aldehyde (e.g., 4-chlorobenzaldehyde)
- Aniline
- Deionized water
- High-pressure stainless steel autoclave (e.g., 5 cm³ volume)
- Nitrogen gas for purging
- Heating apparatus capable of reaching 400°C
- Analytical instruments (GC-MS, NMR) for product characterization

Procedure:

- The high-pressure reactor is charged with the aromatic aldehyde and aniline in a 1:2 molar ratio.[2]
- A specific amount of deionized water is added to the reactor to achieve the desired water density upon heating (e.g., 0.75 g for a 5 cm³ reactor to achieve a density of 0.15 g/cm³).[2]
- The reactor is sealed, and the air inside is replaced with nitrogen by successive purging.
- The reactor is heated to the target temperature (e.g., 350°C) and held for the specified reaction time (e.g., 3 minutes). The heating time is not included in the reaction time.[2]
- After the reaction, the reactor is rapidly cooled to room temperature.
- The reaction mixture is extracted with an appropriate organic solvent (e.g., ethyl acetate).
- The organic phase is dried over anhydrous sodium sulfate, filtered, and the solvent is removed under reduced pressure.
- The product is purified, typically by column chromatography, and characterized by analytical methods.

Visualization:

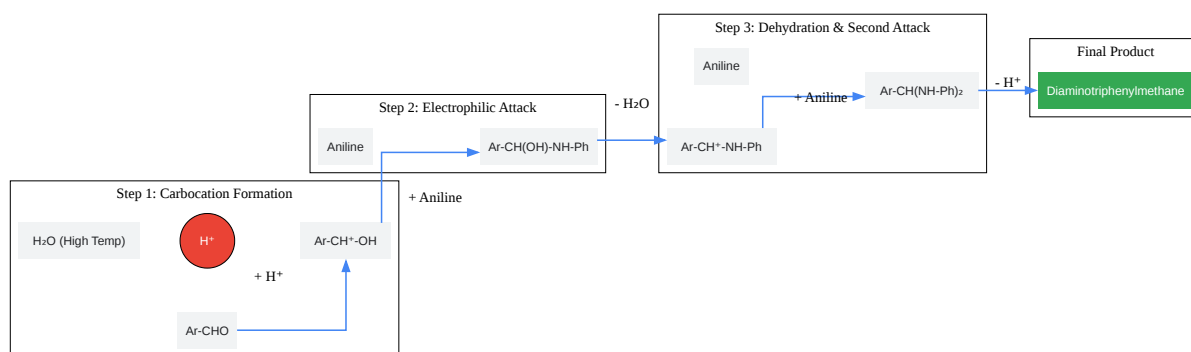

[Click to download full resolution via product page](#)

Caption: Proposed mechanism for non-catalytic condensation.

Application Note 2: Aqueous Micellar Suzuki Cross-Coupling for the Synthesis of Thienyl-Anilines

Introduction: The Suzuki-Miyaura cross-coupling is a powerful tool for forming C-C bonds. Performing this reaction in water is highly desirable from a green chemistry perspective. Micellar catalysis, using surfactants like Kolliphor EL, enables the formation of "nanoreactors" in water where hydrophobic reactants and catalysts can concentrate, leading to efficient reactions at room temperature and often without the need for an inert atmosphere.[3]

Data Presentation:

The following table summarizes results for the Suzuki cross-coupling of monobromoanilines with thienyl boronic acids in an aqueous micellar system.[3][4]

Entry	Bromoaniline	Thiophene Boronic Acid	Time (min)	Yield (%)
1	2-Bromoaniline	2-Thienyl boronic acid	15	98
2	3-Bromoaniline	2-Thienyl boronic acid	15	96
3	4-Bromoaniline	2-Thienyl boronic acid	15	97
4	2-Bromoaniline	3-Thienyl boronic acid	15	95
5	4-Bromoaniline	3-Thienyl boronic acid	15	96

Experimental Protocol:

Materials:

- Bromoaniline derivative (e.g., 2-bromoaniline, 0.5 mmol)
- Thiophene boronic acid derivative (0.6 mmol)
- Palladium catalyst (e.g., Pd(dtbpf)Cl₂, 0.01 mmol)
- Triethylamine (Et₃N, 1 mmol)
- Aqueous Kolliphor EL solution (e.g., 2% w/w in water, 2 mL)
- Ethanol
- Standard glassware and magnetic stirrer

Procedure:

- In a flask, combine the bromoaniline (0.5 mmol), thiophene boronic acid (0.6 mmol), Pd(dtbpf)Cl₂ (0.01 mmol), and triethylamine (1 mmol).[3]
- Add the aqueous Kolliphor EL solution (2 mL).
- Stir the mixture vigorously (e.g., 500 rpm) at room temperature for the time specified (e.g., 15 minutes). The reaction can be monitored by TLC.
- Upon completion, add ethanol (approx. 10 mL) until the reaction mixture becomes homogeneous.
- Remove the solvents under reduced pressure.
- Purify the residue by flash column chromatography (e.g., SiO₂, CH₂Cl₂/n-hexane 8:2) to obtain the pure product.[3]

Visualization:

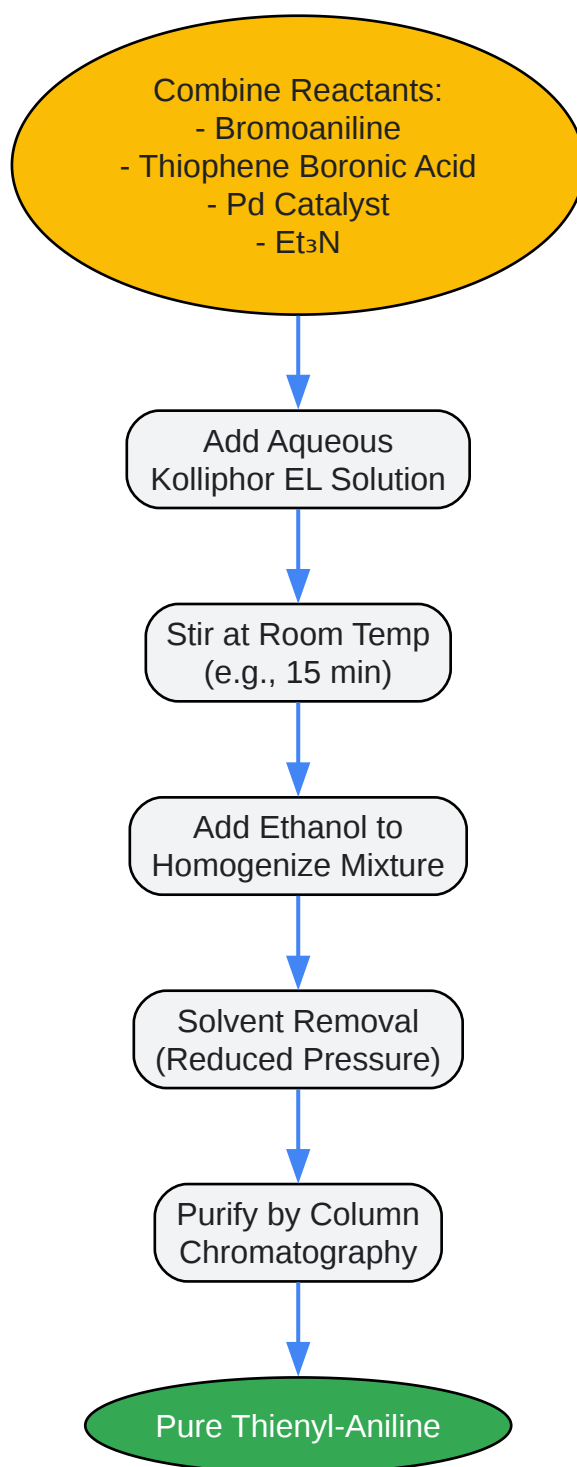

[Click to download full resolution via product page](#)

Caption: Workflow for Micellar Suzuki Cross-Coupling.

Application Note 3: Zinc-Mediated Chemoselective Reduction of Nitroarenes in Water

Introduction: The reduction of nitroarenes to anilines is a fundamental transformation in organic synthesis. Many traditional methods require harsh conditions or expensive catalysts. A green and cost-effective alternative is the use of zinc metal in an aqueous medium, often with an additive like ammonium chloride.^[5] This method is highly chemoselective for the nitro group, leaving other reducible functional groups such as esters, amides, and halides unaffected.^{[5][6]}

Data Presentation:

The following table shows the results for the zinc-mediated reduction of various substituted nitroarenes to the corresponding anilines in water.

Entry	Substrate	Time (h)	Temperature (°C)	Yield (%)
1	Nitrobenzene	1.0	80	95
2	4-Chloronitrobenzene	1.0	80	98
3	4-Nitrotoluene	1.0	80	96
4	Methyl 4-nitrobenzoate	1.5	80	94
5	2,6-Dimethylnitrobenzene	2.0	80	90

Experimental Protocol:

Materials:

- Substituted nitroarene (1.0 mmol)
- Zinc dust (5.0 mmol)

- Ammonium chloride (NH_4Cl , 1.2 mmol)
- Water
- Standard laboratory glassware, heating mantle, and magnetic stirrer

Procedure:

- To a round-bottom flask, add the nitroarene (1.0 mmol), zinc dust (5.0 mmol), ammonium chloride (1.2 mmol), and water (e.g., 5-10 mL).[7]
- Heat the suspension with vigorous stirring to 80°C.[5]
- Monitor the reaction progress using TLC. The reaction is typically complete within 1-2 hours.
- After the reaction is complete, cool the mixture to room temperature and filter it through a pad of celite to remove the excess zinc and zinc salts.
- Wash the celite pad with a suitable organic solvent (e.g., ethyl acetate).
- Extract the aqueous filtrate with the same organic solvent.
- Combine the organic layers, dry over anhydrous sodium sulfate, filter, and concentrate under reduced pressure to yield the aniline product.
- Further purification can be performed by chromatography or recrystallization if necessary.

Visualization:

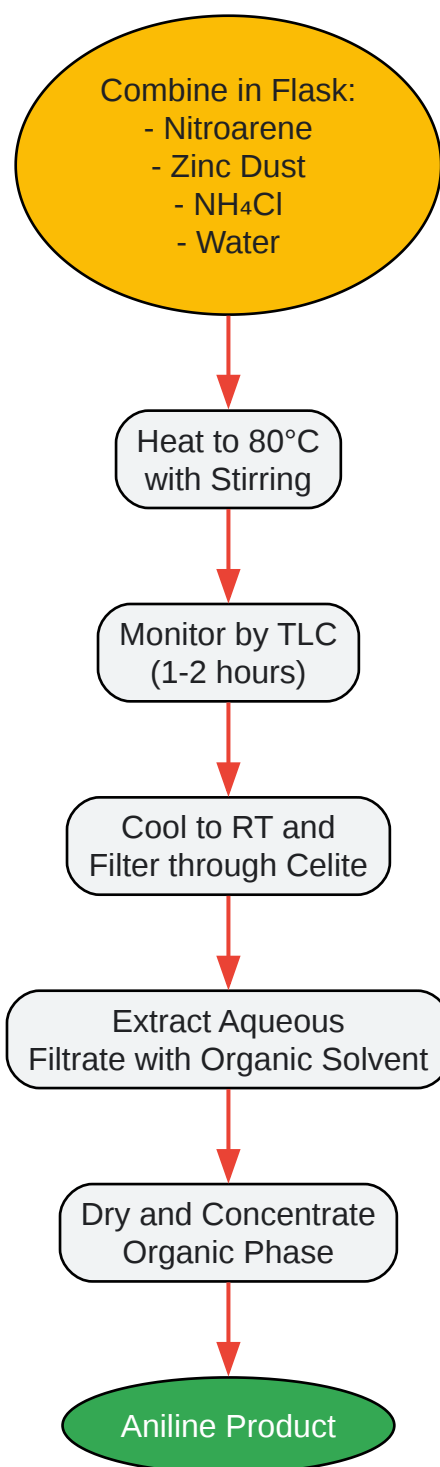

[Click to download full resolution via product page](#)

Caption: Workflow for Zinc-Mediated Nitroarene Reduction.

Need Custom Synthesis?

BenchChem offers custom synthesis for rare earth carbides and specific isotopic labeling.

Email: info@benchchem.com or [Request Quote Online](#).

References

- [1. tandfonline.com](https://www.tandfonline.com) [[tandfonline.com](https://www.tandfonline.com)]
- [2. tandfonline.com](https://www.tandfonline.com) [[tandfonline.com](https://www.tandfonline.com)]
- [3. mdpi.com](https://www.mdpi.com) [[mdpi.com](https://www.mdpi.com)]
- [4. boa.unimib.it](https://www.boa.unimib.it) [[boa.unimib.it](https://www.boa.unimib.it)]
- Organic reaction in water. Part 5. Novel synthesis of anilines by zinc metal-mediated chemoselective reduction of nitroarenes - Green Chemistry (RSC Publishing) [pubs.rsc.org]
- [6. researchgate.net](https://www.researchgate.net) [[researchgate.net](https://www.researchgate.net)]
- Chemoselective Reductions of Nitroaromatics in Water at Room Temperature - PMC [[pmc.ncbi.nlm.nih.gov](https://pubmed.ncbi.nlm.nih.gov)]
- To cite this document: BenchChem. [Application Notes and Protocols for Aniline in Aqueous Synthetic Systems]. BenchChem, [2026]. [Online PDF]. Available at: [<https://www.benchchem.com/product/b12563989/docs#application-notes-and-protocols-for-aniline-in-aqueous-synthetic-systems>]

Disclaimer & Data Validity:

The information provided in this document is for Research Use Only (RUO) and is strictly not intended for diagnostic or therapeutic procedures. While BenchChem strives to provide accurate protocols, we make no warranties, express or implied, regarding the fitness of this product for every specific experimental setup.

Technical Support: The protocols provided are for reference purposes. Unsure if this reagent suits your experiment?

Need Industrial/Bulk Grade? [Request Custom Synthesis Quote](#)

BenchChem

Our mission is to be the trusted global source of essential and advanced chemicals, empowering scientists and researchers to drive progress in science and industry.

Contact

Address: 3281 E Guasti Rd
Ontario, CA 91761, United States
Phone: (601) 213-4426
Email: info@benchchem.com

[Contact our Ph.D. Support Team for a compatibility check](#)