

Technical Support Center: Reducing Background Fluorescence of 4-Azido-DFMQ Probes

Author: BenchChem Technical Support Team. **Date:** April 2026

Compound of Interest

Compound Name: 4-Azido-6,8-difluoro-2-methylquinoline

Cat. No.: B12546054

[Get Quote](#)

Product: **4-Azido-6,8-difluoro-2-methylquinoline** (4-Azido-DFMQ) Application: Photoaffinity Labeling, Bioorthogonal Chemistry (Click), Fluorogenic Probing Document Type: Troubleshooting Guide & FAQ Audience: Senior Researchers, Medicinal Chemists, Chemical Biologists

Core Mechanism & Sources of Background

To effectively reduce background fluorescence, it is essential to understand the "Turn-On" mechanism of 4-Azido-DFMQ.

- The "Dark" State (Intact Probe): The azido group ($-N_3$) at the 4-position acts as a potent fluorescence quencher, typically via Photoinduced Electron Transfer (PET) to the quinoline core. In its pure, intact form, the probe should exhibit minimal fluorescence.
- The "Bright" State (Signal): Upon reaction (e.g., Click chemistry with an alkyne) or photolysis (UV irradiation \rightarrow nitrene insertion), the quenching effect is removed or altered, restoring the strong fluorescence of the quinoline scaffold (typically Blue/Cyan emission).

- The "Background" (Noise): Background signal arises when the "Dark" state is compromised before the specific labeling event.

Diagram: Pathways to Background Fluorescence

The following diagram illustrates the specific chemical pathways that generate unwanted background signal versus the desired specific signal.

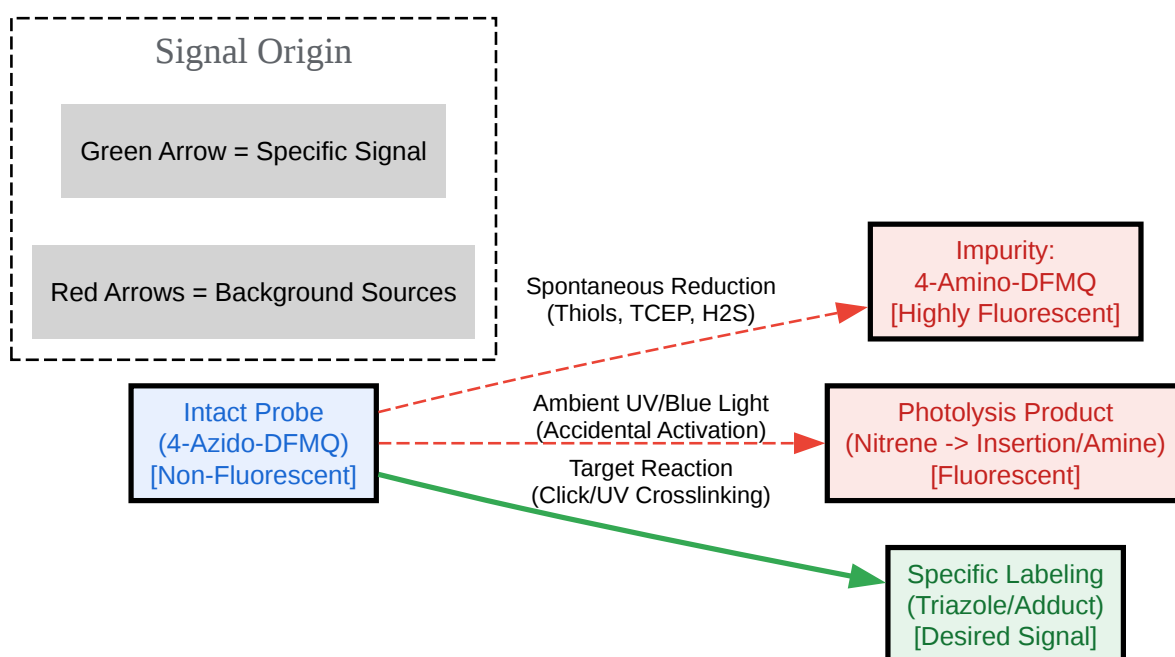

[Click to download full resolution via product page](#)

Figure 1: Mechanistic pathways showing how environmental factors (reductants, light) convert the non-fluorescent probe into fluorescent background species.

Troubleshooting Guide: Diagnosing High Background

If you observe high background fluorescence in your controls (No-Target or No-Click controls), use this matrix to identify the root cause.

Observation	Likely Cause	Corrective Action
High fluorescence in stock solution	Purity Issue: The probe has degraded to the amine (4-Amino-DFMQ) during storage.	Action: Check purity via HPLC/TLC. If >5% amine, repurify or discard. Store solid at -20°C under Argon.
Increasing background over time	Buffer Incompatibility: Presence of reducing agents (DTT, BME, TCEP) is reducing the azide to an amine.	Action: Remove all reducing agents from buffers. Use non-reducing alternatives or dialyze samples before labeling.
High background after handling	Photolysis: Exposure to ambient light (especially fluorescent room light) has activated the azide.	Action: Handle in low-light conditions (amber tubes, dark room). Use red-light filters if possible.
Non-specific cellular staining	Hydrophobicity: The quinoline core is intercalating into membranes or hydrophobic pockets.	Action: Add washing steps with 0.1% Tween-20 or BSA blocking. Optimize probe concentration (titrate down).
Signal in "No-UV" control	Thermal Reactivity: The azide is reacting thermally or spontaneously reducing in the cellular environment (e.g., high intracellular GSH).	Action: Use a scavenger (e.g., iodoacetamide) to block thiols if compatible, or shorten incubation times.

Critical Protocols for Background Reduction

Protocol A: Purity Check (Pre-Experiment QC)

Before committing valuable samples, verify the integrity of your probe.

- Prepare a 10 μ M solution of 4-Azido-DFMQ in analytical grade DMSO.
- Measure Fluorescence Emission (Excitation: ~350 nm, Emission Scan: 400–600 nm).
- Benchmark:

- Pass: Fluorescence is <5% of a positive control (e.g., fully reduced amine or reacted standard).
- Fail: Significant emission peak at ~450 nm indicates free amine contamination.
- Remediation: If contaminated, purify via semi-prep HPLC (C18 column, Water/Acetonitrile gradient) or recrystallization (if scale permits).

Protocol B: Optimized Labeling Workflow

Designed to minimize non-specific activation.

- Buffer Preparation:
 - Use degassed PBS or HEPES (pH 7.4).
 - CRITICAL: Ensure NO DTT, Mercaptoethanol, or TCEP are present. These rapidly reduce azides to fluorescent amines [1].
- Probe Addition:
 - Dilute probe immediately before use. Do not store dilute working solutions.
 - Add probe to samples in the dark.
- Incubation:
 - Incubate at 4°C or Room Temp (avoid 37°C if thermal instability is suspected) for the minimum required time (typically 30–60 mins).
 - Keep samples wrapped in foil.
- Washing (Crucial Step):
 - Perform 3x washes with ice-cold buffer + 1% BSA (or 0.1% Tween-20).
 - Why? BSA acts as a "sink" to sequester unbound, hydrophobic probe molecules that might otherwise stick to membranes and fluoresce [2].

- Imaging/Analysis:
 - Image immediately. Avoid prolonged exposure to excitation light before capturing data, as the excitation beam itself can cause photolysis and "burn-in" background.

Frequently Asked Questions (FAQ)

Q: Can I use TCEP to quench the reaction? A:NO. TCEP will reduce unreacted azide to the amine, causing a massive spike in background fluorescence ("Turn-On" of the unreacted probe). Use a specific scavenger like an alkyne-biotin (to click away excess) or simply wash thoroughly. If you must stop a reaction, rapid dilution and washing are preferred.

Q: My cells have high autofluorescence in the blue channel. How do I distinguish the probe? A: The 6,8-difluoro modification often improves quantum yield and photostability, but the emission is still in the blue/cyan region (~450 nm), overlapping with NADH/NADPH.

- Solution 1: Use a narrow bandpass filter centered on the probe's peak (check specific spectra, typically ~450 nm).
- Solution 2: Use Time-Gated Imaging if your instrument supports it. Quinolines often have different fluorescence lifetimes compared to cellular autofluorescence.
- Solution 3: Increase the signal-to-noise ratio by using a higher affinity target or increasing the specific labeling efficiency (e.g., using Cu(I) catalysis if compatible).

Q: Why is the "difluoro" modification important? A: Fluorination (6,8-difluoro) on the quinoline ring typically:

- Lowers the pKa of the hydroxyl group (if present as a tautomer), ensuring the molecule is in the correct protonation state at physiological pH [3].
- Increases Photostability: Fluorine atoms protect the ring from oxidative degradation, allowing for longer imaging times without bleaching.
- Reduces Aggregation: Fluorine can modulate the lipophilicity, potentially reducing non-specific hydrophobic aggregation compared to the non-fluorinated parent [4].

References

- Niles, A. L., et al. (2007). "Reduction of Azides to Amines by Dithiothreitol (DTT) and Other Thiols: Implications for Bioorthogonal Chemistry." *Journal of the American Chemical Society*. [Link](#)
- Speers, A. E., & Cravatt, B. F. (2004). "Profiling Enzyme Activities In Vivo Using Click Chemistry Methods." *Chemistry & Biology*. [Link](#)
- Sun, W. C., et al. (1997). "Synthesis of Fluorinated Coumarins: Baltimore-City Dyes." *Bioorganic & Medicinal Chemistry Letters*. (Analogous fluorination effects on pKa and spectra). [Link](#)
- Shieh, P., et al. (2015). "Fluorogenic Azidofluoresceins for Biological Imaging." *Journal of the American Chemical Society*. (Discusses azide quenching mechanism). [Link](#)

Disclaimer: This guide is for research use only. Always consult the specific Safety Data Sheet (SDS) for 4-Azido-DFMQ before handling.

- To cite this document: BenchChem. [Technical Support Center: Reducing Background Fluorescence of 4-Azido-DFMQ Probes]. BenchChem, [2026]. [Online PDF]. Available at: [\[https://www.benchchem.com/product/b12546054/docs#technical-support-center-reducing-background-fluorescence-of-4-azido-dfmq-probes\]](https://www.benchchem.com/product/b12546054/docs#technical-support-center-reducing-background-fluorescence-of-4-azido-dfmq-probes)

Disclaimer & Data Validity:

The information provided in this document is for Research Use Only (RUO) and is strictly not intended for diagnostic or therapeutic procedures. While BenchChem strives to provide accurate protocols, we make no warranties, express or implied, regarding the fitness of this product for every specific experimental setup.

Technical Support: The protocols provided are for reference purposes. Unsure if this reagent suits your experiment?

Need Industrial/Bulk Grade? [Request Custom Synthesis Quote](#)

BenchChem

Our mission is to be the trusted global source of essential and advanced chemicals, empowering scientists and researchers to drive progress in science and industry.

Contact

Address: 3281 E Guasti Rd

Ontario, CA 91761, United States

Phone: (601) 213-4426

Email: info@benchchem.com

[Contact our Ph.D. Support Team for a compatibility check](#)