

Parsonsine CAS number and molecular weight

Author: BenchChem Technical Support Team. **Date:** December 2025

Compound of Interest

Compound Name: Parsonsine

Cat. No.: B1254813

[Get Quote](#)

In-Depth Technical Guide to Parsonsine

For Researchers, Scientists, and Drug Development Professionals

Abstract

Parsonsine, a pyrrolizidine alkaloid, has garnered interest within the scientific community for its potential biological activities. This technical guide provides a comprehensive overview of the current knowledge on **Parsonsine**, focusing on its chemical properties, putative mechanisms of action, and relevant experimental protocols. The information is tailored for researchers, scientists, and professionals involved in drug development and natural product chemistry.

Chemical and Physical Properties

Parsonsine is a naturally occurring pyrrolizidine alkaloid found in plants of the *Parsonsia* genus, notably *Parsonsia alboflavescens*.^[1] Pyrrolizidine alkaloids are a class of heterocyclic organic compounds synthesized by plants as a defense mechanism.^{[2][3]}

Table 1: Chemical and Physical Data for **Parsonsine**

Property	Value	Source
CAS Number	72213-98-0	PubChem
Molecular Formula	C ₂₂ H ₃₃ NO ₈	PubChem
Molecular Weight	439.5 g/mol	PubChem

Putative Biological Activities and Mechanisms of Action

Current research suggests that **Parsonsine** exhibits biological activity primarily through two mechanisms: acetylcholinesterase inhibition and antimicrobial effects.

Acetylcholinesterase Inhibition

Several pyrrolizidine alkaloids have been identified as inhibitors of acetylcholinesterase (AChE).[4] This enzyme is responsible for the breakdown of the neurotransmitter acetylcholine in the synaptic cleft.[5][6] By inhibiting AChE, **Parsonsine** may increase the concentration and duration of action of acetylcholine, a key neurotransmitter involved in various cognitive and physiological processes.[7][8][9]

The cholinergic signaling pathway is crucial for neurotransmission. Acetylcholine released from the presynaptic neuron binds to nicotinic and muscarinic receptors on the postsynaptic membrane, initiating a signal. Acetylcholinesterase, present in the synaptic cleft, terminates this signal by hydrolyzing acetylcholine. Inhibition of this enzyme leads to an accumulation of acetylcholine, thereby enhancing cholinergic neurotransmission.[1][10]

Antimicrobial Activity

Pyrrolizidine alkaloids, as a class, have demonstrated antimicrobial properties against a range of bacteria and fungi.[4][11][12] The proposed mechanisms for their antimicrobial action include the disruption of microbial cell membranes, inhibition of nucleic acid and protein synthesis, and interference with essential enzymatic activities.[12][13] The specific antimicrobial spectrum and mechanism of action for **Parsonsine** require further investigation.

Synthesis and Isolation

Detailed, specific protocols for the total synthesis of **Parsonsine** are not readily available in the current literature. However, general strategies for the synthesis of pyrrolizidine alkaloids have been described. These approaches often involve the construction of the bicyclic pyrrolizidine core, followed by the introduction of various functional groups.[14][15]

The biosynthesis of pyrrolizidine alkaloids in plants begins with the amino acid arginine, which is converted to putrescine and spermidine. The enzyme homospermidine synthase then

catalyzes a key step in forming the characteristic pyrrolizidine ring structure.[16]

Isolation of **Parsonsine** from its natural source, *Parsonsia alboflavescens*, would typically involve extraction of the plant material with a suitable solvent, followed by chromatographic separation and purification techniques to isolate the pure compound.

Experimental Protocols

The following are generalized protocols that can be adapted for the study of **Parsonsine's** biological activities.

Acetylcholinesterase Inhibition Assay (Ellman's Method)

This colorimetric assay is a standard method for determining acetylcholinesterase activity and screening for inhibitors.

Materials:

- Acetylcholinesterase (AChE) enzyme
- Acetylthiocholine iodide (ATCI) - substrate
- 5,5'-Dithiobis(2-nitrobenzoic acid) (DTNB) - Ellman's reagent
- Phosphate buffer (pH 8.0)
- **Parsonsine** (test compound)
- 96-well microplate
- Microplate reader

Procedure:

- Prepare solutions of AChE, ATCI, DTNB, and **Parsonsine** in phosphate buffer at appropriate concentrations.
- In a 96-well plate, add phosphate buffer, the test compound (**Parsonsine**) at various concentrations, and the AChE solution to each well.

- Incubate the plate at a controlled temperature (e.g., 37°C) for a defined period (e.g., 15 minutes).
- Initiate the reaction by adding the substrate, ATCI, to all wells.
- Simultaneously, add DTNB to all wells. The hydrolysis of ATCI by AChE produces thiocholine, which reacts with DTNB to form a yellow-colored product (5-thio-2-nitrobenzoate).
- Measure the absorbance of the wells at a specific wavelength (typically 412 nm) at regular intervals using a microplate reader.
- The rate of color change is proportional to the AChE activity. The percentage of inhibition by **Parsonsine** can be calculated by comparing the reaction rates in the presence and absence of the inhibitor.

Antimicrobial Activity Assay (Broth Microdilution Method)

This method is used to determine the Minimum Inhibitory Concentration (MIC) of an antimicrobial agent.

Materials:

- **Parsonsine** (test compound)
- Bacterial or fungal strains of interest
- Appropriate liquid growth medium (e.g., Mueller-Hinton broth for bacteria, Sabouraud dextrose broth for fungi)
- 96-well microplate
- Spectrophotometer or microplate reader

Procedure:

- Prepare a stock solution of **Parsonsine** in a suitable solvent.

- Perform serial two-fold dilutions of the **Parsonsine** stock solution in the growth medium directly in the wells of a 96-well plate.
- Inoculate each well with a standardized suspension of the microorganism to be tested.
- Include positive control wells (microorganism in medium without **Parsonsine**) and negative control wells (medium only).
- Incubate the plate under appropriate conditions (e.g., 37°C for 24 hours for bacteria).
- After incubation, determine the MIC by visually inspecting for the lowest concentration of **Parsonsine** that completely inhibits visible growth of the microorganism. The MIC can also be determined by measuring the optical density at 600 nm.

Visualizations

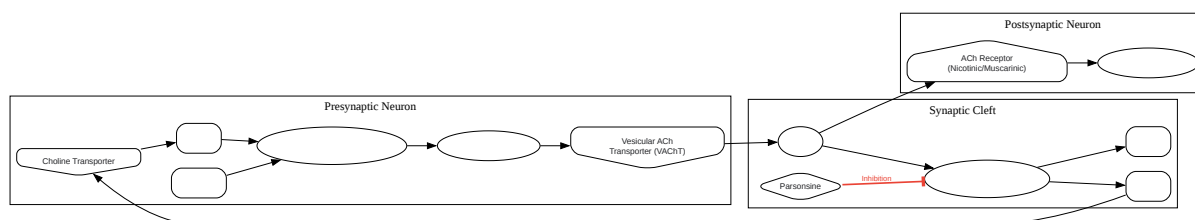

[Click to download full resolution via product page](#)

Caption: Acetylcholinesterase Signaling Pathway Inhibition by **Parsonsine**.

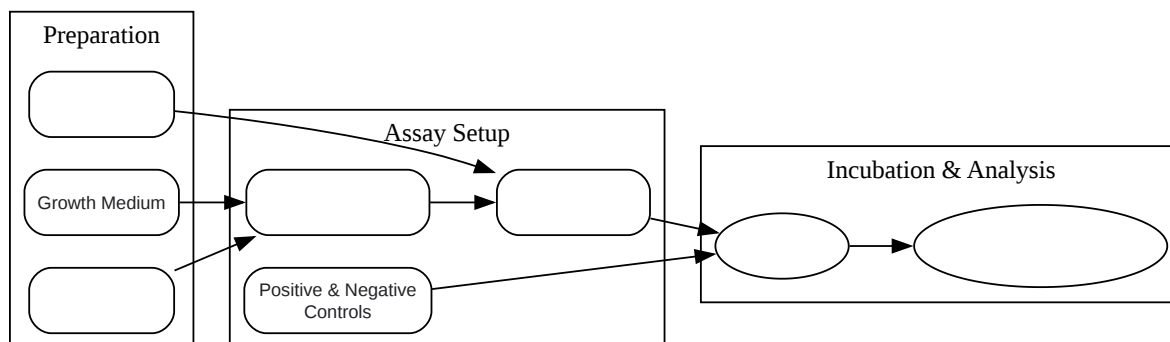

[Click to download full resolution via product page](#)

Caption: Workflow for Determining the Minimum Inhibitory Concentration (MIC) of **Parsonsine**.

Need Custom Synthesis?

BenchChem offers custom synthesis for rare earth carbides and specific isotopic labeling.

Email: info@benchchem.com or [Request Quote Online](#).

References

- 1. Acetylcholine - Wikipedia [en.wikipedia.org]
- 2. researchgate.net [researchgate.net]
- 3. Pyrrolizidine Alkaloids: Biosynthesis, Biological Activities and Occurrence in Crop Plants [mdpi.com]
- 4. Pyrrolizidine Alkaloids—Pros and Cons for Pharmaceutical and Medical Applications - PMC [pmc.ncbi.nlm.nih.gov]
- 5. Physiology, Acetylcholinesterase - StatPearls - NCBI Bookshelf [ncbi.nlm.nih.gov]
- 6. Acetylcholinesterase - Wikipedia [en.wikipedia.org]
- 7. Acetylcholinesterase inhibitor - Wikipedia [en.wikipedia.org]
- 8. Acetylcholinesterase Inhibitors: Pharmacology and Toxicology - PMC [pmc.ncbi.nlm.nih.gov]

- 9. Cholinesterase Inhibitors - StatPearls - NCBI Bookshelf [ncbi.nlm.nih.gov]
- 10. KEGG PATHWAY: map04725 [genome.jp]
- 11. mdpi.com [mdpi.com]
- 12. Antibacterial Activity and Antifungal Activity of Monomeric Alkaloids - PMC [pmc.ncbi.nlm.nih.gov]
- 13. Research Progress on Antibacterial Activities and Mechanisms of Natural Alkaloids: A Review - PMC [pmc.ncbi.nlm.nih.gov]
- 14. Recent advances on the synthesis of natural pyrrolizidine alkaloids: alexine, and its stereoisomers - PMC [pmc.ncbi.nlm.nih.gov]
- 15. pubs.acs.org [pubs.acs.org]
- 16. Pyrrolizidine alkaloid - Wikipedia [en.wikipedia.org]
- To cite this document: BenchChem. [Parsonsine CAS number and molecular weight]. BenchChem, [2025]. [Online PDF]. Available at: [https://www.benchchem.com/product/b1254813#parsonsine-cas-number-and-molecular-weight]

Disclaimer & Data Validity:

The information provided in this document is for Research Use Only (RUO) and is strictly not intended for diagnostic or therapeutic procedures. While BenchChem strives to provide accurate protocols, we make no warranties, express or implied, regarding the fitness of this product for every specific experimental setup.

Technical Support: The protocols provided are for reference purposes. Unsure if this reagent suits your experiment? [[Contact our Ph.D. Support Team for a compatibility check](#)]

Need Industrial/Bulk Grade? [Request Custom Synthesis Quote](#)

BenchChem

Our mission is to be the trusted global source of essential and advanced chemicals, empowering scientists and researchers to drive progress in science and industry.

Contact

Address: 3281 E Guasti Rd

Ontario, CA 91761, United States

Phone: (601) 213-4426

Email: info@benchchem.com