

Advanced Characterization of Hexyl Thiophene Compounds: From Photophysics to Bioelectronic Applications

Author: BenchChem Technical Support Team. **Date:** April 2026

Compound of Interest

Compound Name:	4,5-Bis(5-hexyl-2-thienyl)thiophene-2-carbaldehyde
CAS No.:	705240-03-5
Cat. No.:	B12532667

[Get Quote](#)

Executive Summary

This technical guide provides a rigorous analysis of poly(3-hexylthiophene) (P3HT) and its oligomeric derivatives, focusing on the critical structure-property relationships that drive their utility in organic electronics and emerging bio-medical applications. While traditionally viewed as the "fruit fly" of organic photovoltaics (OPV), P3HT's biocompatibility and mixed ionic-electronic conductivity have recently positioned it as a scaffold for drug delivery systems and bio-electronic sensors.

This document is designed for researchers requiring actionable protocols for synthesizing high-regioregularity materials, accurately determining energy levels via cyclic voltammetry (CV), and interpreting complex photophysical aggregate signatures.

Part 1: Molecular Architecture & Synthesis Strategy

The electronic performance of hexyl thiophene compounds is dictated by Regioregularity (RR)—the percentage of Head-to-Tail (HT) couplings between thiophene rings. High RR (>95%) induces planarization, facilitating

stacking and enhancing charge carrier mobility by orders of magnitude (

to

cm

Vs).

Synthesis Protocol: Grignard Metathesis (GRIM)

To achieve high RR suitable for device-grade applications, the Kumada Catalyst-Transfer Polycondensation (KCTP), specifically the GRIM method, is the gold standard.

Protocol:

- **Monomer Activation:** 2,5-dibromo-3-hexylthiophene is treated with isopropylmagnesium chloride ($i\text{-PrMgCl}$) in THF at 0°C . Critical Step: This results in an 85:15 mixture of isomers; however, the catalyst selectively polymerizes the correct isomer.
- **Polymerization:** Add Ni(dppp)Cl catalyst. The reaction proceeds via a chain-growth mechanism.
- **Quenching:** Terminate with HCl (or functionalized Grignard reagent for end-capping).
- **Purification:** Soxhlet extraction with methanol (removes salts), hexanes (removes oligomers), and finally chloroform (collects high MW polymer).

Structural Impact on Packing

The hexyl side chain confers solubility, but its placement determines the crystal lattice.

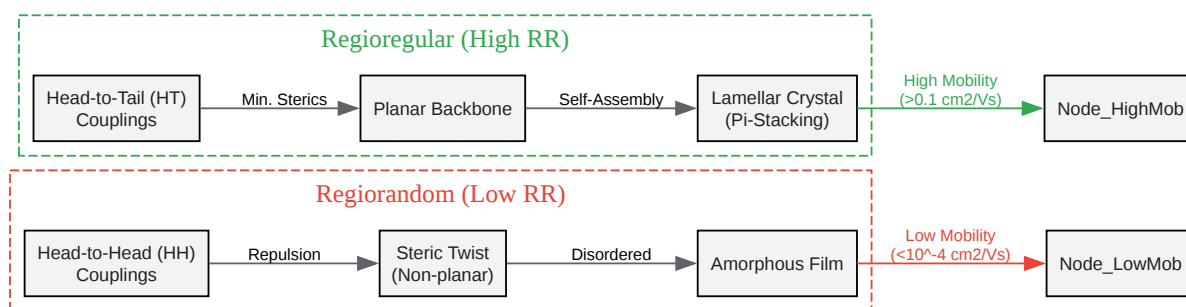

[Click to download full resolution via product page](#)

Figure 1: Impact of regioregularity on molecular conformation and solid-state packing.

Part 2: Photophysical Profiling

P3HT exhibits distinct solvatochromism, serving as a probe for chain conformation (coil vs. rod).

Absorption & Emission Characteristics

In a good solvent (e.g., Chloroform), P3HT exists as a random coil. In the solid state or poor solvents, it aggregates, leading to planarization and delocalization of the exciton.

Property	Solution (Chloroform)	Thin Film (Annealed)	Mechanistic Origin
Abs	~450 nm	510–550 nm	Planarization increases conjugation length.
Vibronic Features	Absent (Broad)	Distinct shoulders (600 nm)	Interchain vibronic coupling (π-π stacking).
Emission	~580 nm	~660–700 nm	Energy migration to low-energy aggregate sites.
Quantum Yield (PL)	~33%	< 2%	Strong quenching in films due to H-aggregation.

H- vs. J-Aggregation

Understanding the aggregate type is vital for interpreting spectral data.

- H-Aggregates (Face-to-Face): Dominant in P3HT films. The transition to the lowest excited state is forbidden, resulting in low fluorescence and a blue-shifted absorption relative to the monomeric rod.
- J-Aggregates (Head-to-Tail): Rare in pure P3HT but can be engineered in nanowires. Characterized by high fluorescence and red-shifted absorption.

Diagnostic Ratio: The ratio of the 0-0 to 0-1 vibronic absorption peaks (

) correlates to the exciton bandwidth (

). A lower ratio indicates stronger H-aggregate character (stronger interchain coupling).[1]

Part 3: Electrochemical Properties & Energy Levels[3][4]

Accurate determination of HOMO/LUMO levels is critical for matching P3HT with acceptors (like PCBM or non-fullerene acceptors) or biological redox couples.

Cyclic Voltammetry (CV) Protocol

Objective: Determine the oxidation onset (

) to calculate the HOMO level.[1]

Experimental Setup:

- Working Electrode: Platinum button or ITO slide coated with a thin film of P3HT (drop-cast from 1 mg/mL CHCl₃).
- Counter Electrode: Platinum wire.
- Reference Electrode: Ag/AgCl (in 3M KCl) or Ag/Ag⁺ (non-aqueous).
- Electrolyte: 0.1 M Tetrabutylammonium hexafluorophosphate (TBAPF₆) in anhydrous Acetonitrile.
- Internal Standard: Ferrocene (Fc/Fc⁺) added at the end of the experiment.

Calculation Logic: The vacuum level is typically taken as -4.8 eV or -5.1 eV relative to the Fc/Fc⁺ redox couple.

Note: Literature varies on the constant (4.8 vs 5.1). Consistency within a dataset is more critical than the absolute value.

Typical Values for RR-P3HT:

- HOMO: -4.9 to -5.1 eV
- LUMO: -3.0 to -3.2 eV (Calculated:)

- Optical Bandgap (

): ~1.9 eV (derived from the onset of film absorption ~650 nm).

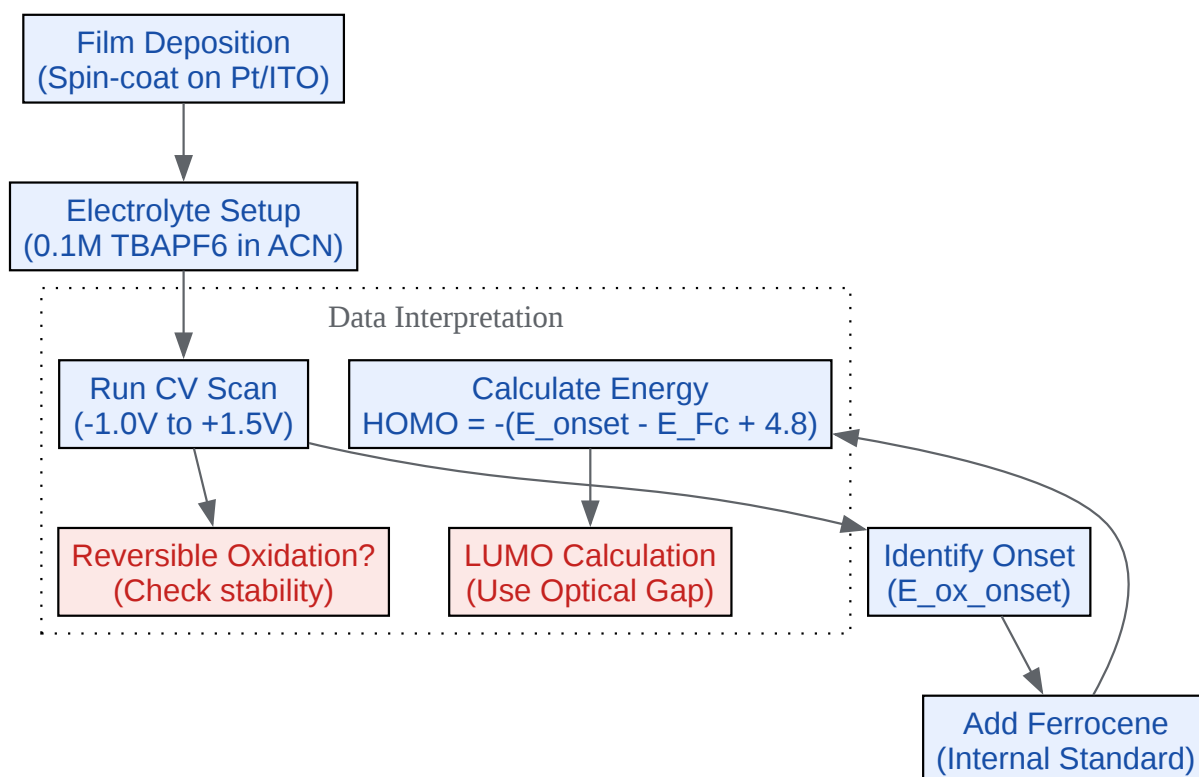

[Click to download full resolution via product page](#)

Figure 2: Step-by-step workflow for electrochemical characterization via Cyclic Voltammetry.

Part 4: Bio-Interface & Drug Delivery Applications

For drug development professionals, P3HT is not just a semiconductor; it is a biocompatible transducer. Its ability to conduct both ions and electrons makes it an ideal interface between biology (ionic) and electronics.

P3HT Nanoparticles (NPs) for Drug Delivery

P3HT can be formulated into nanoparticles using the reprecipitation method. These NPs can encapsulate hydrophobic drugs and release them upon electrical or optical stimulation.

- Mechanism: Light absorption by P3HT generates Reactive Oxygen Species (ROS) or local heat (photothermal effect), which can destabilize the NP matrix or kill proximal cancer cells (photodynamic therapy).
- Biocompatibility: P3HT films support neuronal growth and are used in artificial retina research.

Organic Electrochemical Transistors (OECTs)

P3HT is used as the channel material in OECTs to detect biological analytes (glucose, dopamine).

- Operation: Ions from the biological medium penetrate the P3HT film (volumetric doping), modulating its conductivity.
- Advantage: High transconductance () allows for amplification of weak biological signals.

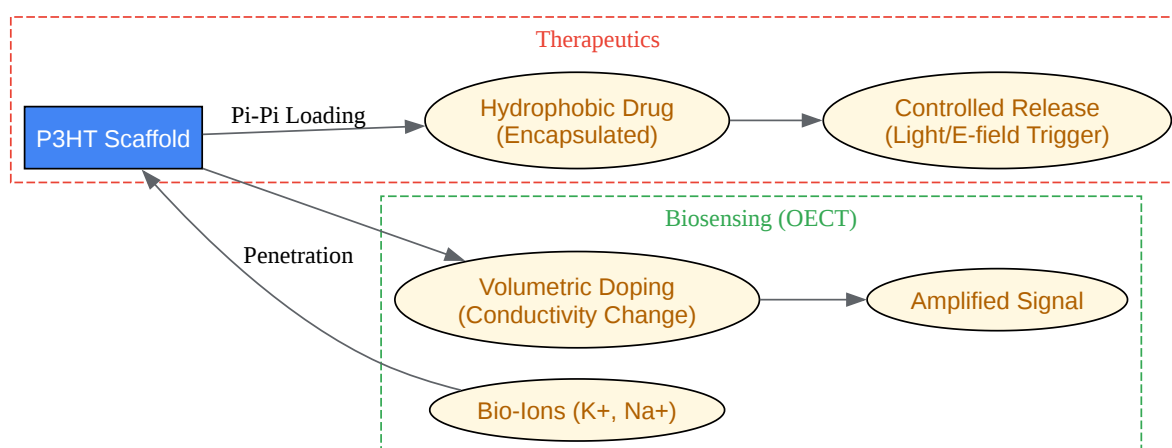

[Click to download full resolution via product page](#)

Figure 3: Dual utility of P3HT in therapeutic delivery and bio-sensing interfaces.

References

- Review of P3HT Bioelectronics: "Poly(3-hexylthiophene) as a versatile semiconducting polymer for cutting-edge bioelectronics." [2][3][4] Materials Horizons. [Link](#)
- Regioregularity Effects: "Effect of Regioregularity on Charge Transport and Structural and Excitonic Coherence in Poly(3-hexylthiophene) Nanowires." Journal of Physical Chemistry C. [Link](#)
- Photophysics & Aggregation: "Photoluminescence in poly(3-hexylthiophene)." Physical Review B. [Link](#)
- Electrochemical Energy Levels: "Measurements of HOMO-LUMO levels of poly(3-hexylthiophene) thin films by a simple electrochemical method." Solar Energy Materials and Solar Cells. [Link](#)
- Synthesis (GRIM Method): "Grignard Metathesis Method (GRIM): A Simple and Efficient Method for the Synthesis of Regioregular Poly(3-alkylthiophenes)." Macromolecules. [Link](#)

Need Custom Synthesis?

BenchChem offers custom synthesis for rare earth carbides and specific isotopic labeling.

Email: info@benchchem.com or [Request Quote Online](#).

Sources

- 1. artefacts-discovery.researcher.life [artefacts-discovery.researcher.life]
- 2. Poly(3-hexylthiophene) as a versatile semiconducting polymer for cutting-edge bioelectronics - PMC [[pmc.ncbi.nlm.nih.gov](https://pubmed.ncbi.nlm.nih.gov/)]
- 3. [researchgate.net](https://www.researchgate.net) [[researchgate.net](https://www.researchgate.net)]
- 4. Poly(3-hexylthiophene) as a versatile semiconducting polymer for cutting-edge bioelectronics - Materials Horizons (RSC Publishing) [pubs.rsc.org]

- To cite this document: BenchChem. [Advanced Characterization of Hexyl Thiophene Compounds: From Photophysics to Bioelectronic Applications]. BenchChem, [2026]. [Online PDF]. Available at: [<https://www.benchchem.com/product/b12532667/docs#advanced-characterization-of-hexyl-thiophene-compounds-from-photophysics-to-bioelectronic-applications>]

Disclaimer & Data Validity:

The information provided in this document is for Research Use Only (RUO) and is strictly not intended for diagnostic or therapeutic procedures. While BenchChem strives to provide accurate protocols, we make no warranties, express or implied, regarding the fitness of this product for every specific experimental setup.

Technical Support: The protocols provided are for reference purposes. Unsure if this reagent suits your experiment?

Need Industrial/Bulk Grade? [Request Custom Synthesis Quote](#)

BenchChem

Our mission is to be the trusted global source of essential and advanced chemicals, empowering scientists and researchers to drive progress in science and industry.

Contact

Address: 3281 E Guasti Rd
Ontario, CA 91761, United States
Phone: (601) 213-4426
Email: info@benchchem.com

[Contact our Ph.D. Support Team for a compatibility check](#)