

Technical Support Center: Troubleshooting Poor Bentazone-Sodium Performance

Author: BenchChem Technical Support Team. **Date:** April 2026

Compound of Interest

Compound Name: *Bentazone-sodium*

CAS No.: 50723-80-3

Cat. No.: B1253995

[Get Quote](#)

This technical support center provides guidance for researchers, scientists, and drug development professionals encountering suboptimal results with **Bentazone-sodium** in field experiments. The following information is designed to help you identify and resolve common issues to ensure the effective application of this herbicide.

Frequently Asked Questions (FAQs)

Q1: What is the mode of action for **Bentazone-sodium**?

Bentazone-sodium is a selective, post-emergence herbicide that primarily acts as a photosystem II (PSII) inhibitor.[1][2][3][4] It is absorbed by the foliage and inhibits photosynthesis, leading to the yellowing or bronzing of leaves, followed by necrosis and death of the susceptible broadleaf weeds and sedges.[1][3][5] Because it is a contact herbicide, thorough spray coverage of the target weed's foliage is crucial for its effectiveness.[3][4]

Q2: What are the ideal environmental conditions for **Bentazone-sodium** application?

Bentazone-sodium performance is significantly influenced by environmental factors. Optimal efficacy is achieved under warm, humid conditions with actively growing weeds.[6] High

temperatures and high relative humidity enhance the absorption of the herbicide.[7][8]

Q3: Can I apply **Bentazone-sodium** during dry or cool weather?

Application during drought, cold weather, or dry and windy conditions can lead to poor weed control.[6] Moisture stress in plants reduces herbicide uptake and effectiveness.[7][8] If application during suboptimal conditions is unavoidable, the use of appropriate adjuvants may help improve uptake, particularly in low humidity.[7]

Q4: Is weed resistance to **Bentazone-sodium** a common issue?

While herbicide resistance is a growing concern, Bentazone-resistant weeds have not been reported in the United States.[1] However, resistant populations of smooth pigweed (*Amaranthus hybridus*) and redroot pigweed (*Amaranthus retroflexus*) have been identified in Ontario, Canada.[1] To prevent the development of resistance, it is recommended to rotate and combine herbicides with different modes of action and utilize mechanical weed control methods.[1]

Q5: Why is **Bentazone-sodium** not effective against grass weeds?

Bentazone-sodium has limited to no activity on grass weeds.[9][10] Its selectivity is due to the rapid metabolic breakdown of the active ingredient in tolerant plants, such as grasses.[10]

Troubleshooting Guides

Issue 1: Poor Weed Control After Application

If you observe minimal or no effect on target weeds after applying **Bentazone-sodium**, consider the following potential causes and solutions.

Potential Causes:

- **Incorrect Application Timing:** Weeds may have been too large or not in an active growth stage. Bentazone is most effective on young, actively growing weeds.[4][11]
- **Adverse Environmental Conditions:** Application during cool, dry, or drought conditions can significantly reduce efficacy.[6][8]

- **Inadequate Spray Coverage:** As a contact herbicide, Bentazone requires thorough coverage of the weed's foliage.[3][4]
- **Rainfall After Application:** Heavy rainfall shortly after application can wash the herbicide off the leaves before it is absorbed. A rainfast period of 4-6 hours is generally recommended. [11]
- **Incorrect Weed Identification:** The target weeds may not be susceptible to Bentazone. It is primarily effective against broadleaf weeds and sedges.[4][9]

Troubleshooting Steps:

- **Verify Weed Stage and Condition:** Confirm that weeds were at the recommended growth stage for treatment at the time of application.
- **Review Environmental Data:** Check temperature, humidity, and soil moisture records for the period before, during, and after application.
- **Evaluate Spray Application Parameters:** Assess spray volume, pressure, and nozzle type to ensure they were adequate for achieving thorough coverage.
- **Check Rainfall Records:** Determine if rainfall occurred within the critical rainfast period.
- **Confirm Weed Susceptibility:** Positively identify the target weed species and confirm they are listed as susceptible on the product label.

Issue 2: Crop Injury Observed

While Bentazone is selective, crop injury can occur under certain conditions.

Potential Causes:

- **Application at High Temperatures and Humidity:** These conditions can increase the potential for leaf burn on the crop.[12]
- **Use of Certain Adjuvants:** Crop oil concentrates and other spray additives can increase both weed control and the risk of crop injury.[1]

- **Incorrect Application Rate:** Exceeding the recommended dose for a specific crop can lead to phytotoxicity.[4]
- **Tank Contamination:** Residual herbicides from a previous spray application can cause unexpected crop damage.[1]

Troubleshooting Steps:

- **Assess Environmental Conditions at Application:** High heat and humidity can exacerbate crop response.
- **Review Adjuvant Use:** Check the type and rate of any adjuvants used in the spray mixture.
- **Verify Application Rate:** Confirm that the correct rate of **Bentazone-sodium** was used for the specific crop and its growth stage.
- **Inspect Sprayer Cleanliness:** Review sprayer cleanout procedures to rule out contamination.

Issue 3: Reduced Performance in a Tank Mix

When **Bentazone-sodium** is tank-mixed with other pesticides, antagonistic interactions can occur, leading to reduced efficacy.

Potential Causes:

- **Antagonism with Grass Herbicides (Graminicides):** Tank-mixing Bentazone with graminicides like sethoxydim or clethodim can reduce the effectiveness of the grass herbicide.[13]
- **Improper Mixing Order:** The order in which products are added to the spray tank is critical for ensuring they mix properly.[14][15]
- **Water Quality Issues:** The pH and mineral content of the water used as a carrier can affect the stability and efficacy of the spray solution.[16]

Troubleshooting Steps:

- **Review Tank-Mix Partners:** Be aware of known antagonisms, particularly with grass herbicides. Consider applying the grass herbicide 1-3 days before the Bentazone application

to avoid this interaction.[13]

- **Verify Mixing Procedure:** Follow the recommended mixing order (e.g., WALES: Wettable powders, Agitate, Liquid flowables, Emulsifiable concentrates, Surfactants).
- **Conduct a Jar Test:** Before mixing a new combination in the spray tank, perform a jar test to check for physical compatibility.
- **Analyze Water Source:** If problems persist, have your water source tested for pH and hardness.

Data Presentation

Table 1: Influence of Environmental Factors on **Bentazone-Sodium** Efficacy

Factor	Optimal Conditions	Suboptimal Conditions	Impact on Performance
Temperature	Warm	Cool	Higher temperatures increase absorption and translocation.[7] [8]
Relative Humidity	High (e.g., 80%)	Low (e.g., 40%)	High humidity enhances uptake; adjuvants can help in low humidity.[7][8]
Soil Moisture	Moist to slightly flooded	Dry/Drought-stressed	Herbicide activity is very low in dry soil.[7] [8]
Light Intensity	High	Low	High light intensity promotes photosynthesis and herbicide movement. [7][17]

Table 2: Recommended Application Parameters for **Bentazone-Sodium**

Parameter	Recommendation	Rationale
Water Volume	Minimum of 300 L/ha	Ensures thorough coverage of weed foliage.[6]
Spray Pressure	Minimum of 350 kPa	Aids in creating droplets that effectively cover the plant surface.[6]
Nozzles	Hollow cone or flat fan	Provide appropriate spray patterns for post-emergence applications.[6]

Experimental Protocols

Protocol 1: Jar Test for Tank-Mix Compatibility

Objective: To determine the physical compatibility of **Bentazone-sodium** with other pesticides or adjuvants in a spray solution.

Materials:

- A clean, clear glass jar with a lid (1-liter or 1-quart)
- Water source to be used for spraying
- The products to be tank-mixed, in the correct proportions
- A measuring cylinder or syringe for accurate measurement

Procedure:

- Fill the jar halfway with the water from the intended source.
- Add the components to the jar in the proper mixing order (WALES or as specified on the product labels).
- Cap the jar and shake it vigorously for 15-30 seconds.

- Let the jar stand for at least 15-30 minutes and observe for any signs of incompatibility.
- Check for separation, layering, precipitation, clumps, gels, or heat generation.
- If any of these signs appear, the products are likely incompatible and should not be tank-mixed.

Visualizations

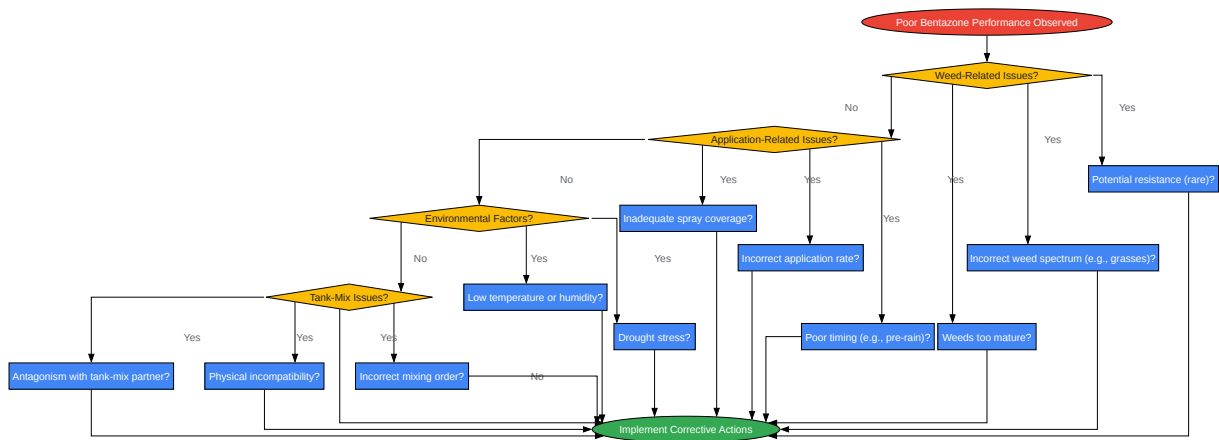

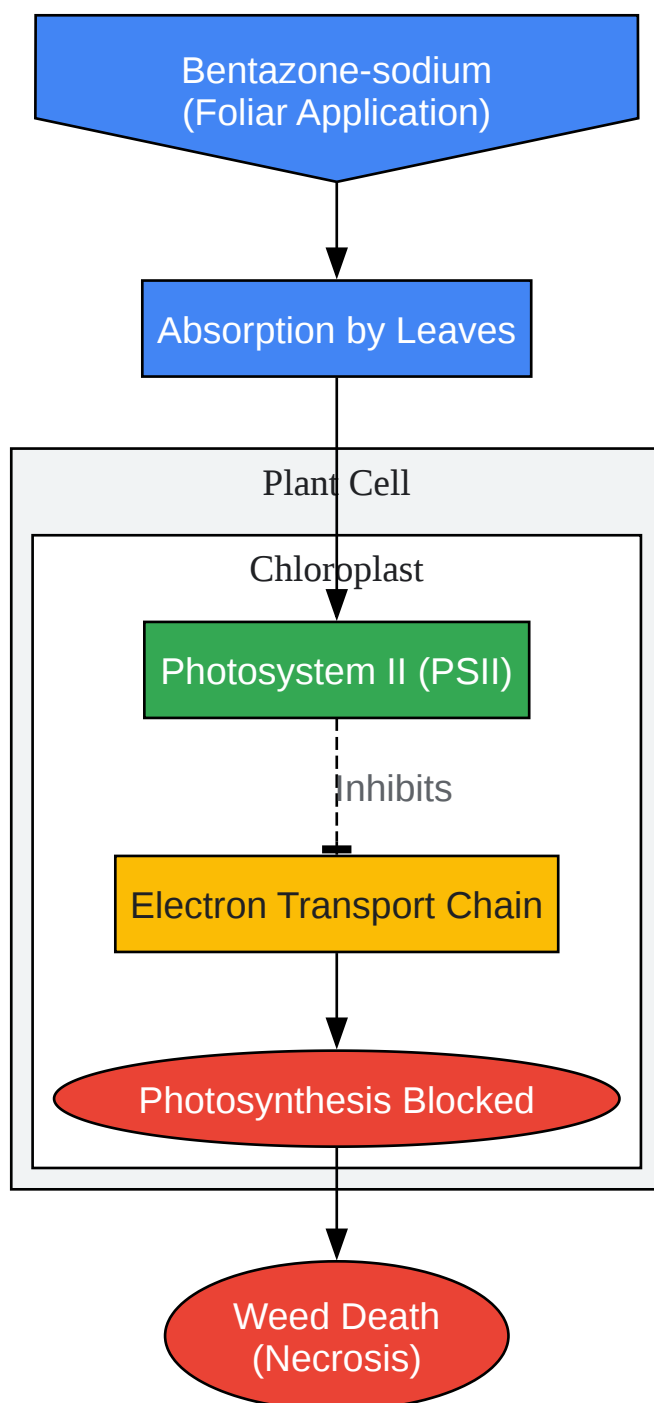

[Click to download full resolution via product page](#)

Need Custom Synthesis?

BenchChem offers custom synthesis for rare earth carbides and specific isotopic labeling.

Email: info@benchchem.com or [Request Quote Online](#).

References

- [1. Bentazon Herbicide | Minnesota Department of Agriculture \[mda.state.mn.us\]](#)
- [2. Bentazone \[sitem.herts.ac.uk\]](#)
- [3. agriculture.basf.com \[agriculture.basf.com\]](#)
- [4. How Bentazone Delivers Targeted Weed Control in Modern Agriculture \[jindunchemical.com\]](#)
- [5. SS-AGR-473/AG469: Diagnosing Herbicide Injury Symptoms in Sugarcane and Rotational Crops in Southern Florida \[edis.ifas.ufl.edu\]](#)
- [6. rolfesagri.co.za \[rolfesagri.co.za\]](#)
- [7. Bentazone Effectivity Modulated by Environmental Conditions - Heilongjiang Taina Technology Development Co., Ltd. \[tainachem.com\]](#)
- [8. mdpi.com \[mdpi.com\]](#)
- [9. The Brief Introduction of Herbicide Bentazone - Knowledge - Zhengzhou Delong Chemical Co., Ltd. \[plantgrowthhormones.com\]](#)
- [10. researchgate.net \[researchgate.net\]](#)
- [11. pomais.com \[pomais.com\]](#)
- [12. vikingcropproduction.com \[vikingcropproduction.com\]](#)
- [13. Check antagonism before pulling trigger on tank-mixed herbicides – The Seam \[theseam.com\]](#)
- [14. agrion.com.au \[agrion.com.au\]](#)
- [15. Avoid Tank Mixing Errors \[ag.purdue.edu\]](#)
- [16. connectsci.au \[connectsci.au\]](#)
- [17. encyclopedia.pub \[encyclopedia.pub\]](#)
- [To cite this document: BenchChem. \[Technical Support Center: Troubleshooting Poor Bentazone-Sodium Performance\]. BenchChem, \[2026\]. \[Online PDF\]. Available at: \[https://www.benchchem.com/product/b1253995/docs#technical-support-center-troubleshooting-poor-bentazone-sodium-performance\]](#)

Disclaimer & Data Validity:

The information provided in this document is for Research Use Only (RUO) and is strictly not intended for diagnostic or therapeutic procedures. While BenchChem strives to provide accurate protocols, we make no warranties, express or implied, regarding the fitness of this product for every specific experimental setup.

Technical Support: The protocols provided are for reference purposes. Unsure if this reagent suits your experiment?

Need Industrial/Bulk Grade? [Request Custom Synthesis Quote](#)

BenchChem

Our mission is to be the trusted global source of essential and advanced chemicals, empowering scientists and researchers to drive progress in science and industry.

Contact

Address: 3281 E Guasti Rd
Ontario, CA 91761, United States
Phone: (601) 213-4426
Email: info@benchchem.com

[Contact our Ph.D. Support Team for a compatibility check](#)