

Carbaprostacyclin Structure-Activity Relationship (SAR) Analysis: A Technical Guide

Author: BenchChem Technical Support Team. **Date:** April 2026

Compound of Interest

Compound Name: Carbacyclic PGI₂

Cat. No.: B1252311

[Get Quote](#)

Executive Summary

Carbaprostacyclin (Carbacyclin) represents a pivotal evolution in prostacyclin (PGI

) mimetics. While endogenous PGI

is the most potent inhibitor of platelet aggregation and a powerful vasodilator, its clinical utility is severely hampered by the chemical instability of its enol-ether moiety (half-life

seconds at physiological pH).

This guide analyzes the Structure-Activity Relationship (SAR) of carbaprostacyclin, where the labile enol-ether oxygen is replaced by a methylene group. This isosteric replacement confers hydrolytic stability (

hours) while retaining affinity for the IP receptor. This document details the specific electronic and steric modifications required to optimize potency, selectivity, and metabolic stability, serving as a blueprint for the development of third-generation analogs like Iloprost and Beraprost.

Chemical Foundation: The Stability-Potency Trade-off

The primary objective of carbaprostacyclin design is to overcome the rapid hydrolysis of PGI into the inactive 6-keto-PGF

The Core Scaffold Modification

- PGI

(Prostacyclin): Contains a cyclic enol-ether system (C6-O-C9). The high electron density of the oxygen atom makes the C5-C6 double bond susceptible to acid-catalyzed hydration, leading to ring opening and inactivation.

- Carbaprostacyclin: Replaces the ether oxygen at position 6 with a methylene carbon (), forming a bicyclic [3.3.0]octane system.
- SAR Implication: This substitution eliminates the leaving group potential of the oxygen, rendering the molecule chemically stable. However, the methylene group lacks the lone pair electrons of oxygen, slightly altering the electrostatic potential surface presented to the receptor, resulting in a 10- to 30-fold reduction in potency compared to native PGI

Detailed SAR Analysis

The biological activity of carbaprostacyclin is governed by three critical structural domains: the geometric isomerism at C5, the

-side chain, and the

-side chain.

Stereochemistry: The 5E vs. 5Z Criticality

The geometry of the double bond at C5 is the single most critical determinant of receptor activation.

Isomer	Configuration	Biological Activity	Mechanism
(5E)-Carbacyclin	Trans-like geometry	Full Agonist	Mimics the spatial arrangement of the PGI enol-ether. High affinity for IP receptor.
(5Z)-Carbacyclin	Cis-like geometry	Partial Agonist / Antagonist	Acts as a full agonist in platelets but a partial agonist/antagonist in vascular smooth muscle (VSMC).[1][2]

Mechanistic Insight: The (5Z) isomer can bind the receptor but fails to induce the conformational change required for maximal G

coupling in all tissue types, demonstrating tissue-specific discrimination likely due to receptor reserve differences or specific G-protein coupling efficiencies.

The -Side Chain (Omega Chain)

Modifications here primarily address metabolic stability (preventing

-oxidation) and hydrophobic pocket filling.

- C-15 Hydroxyl Group: Essential for hydrogen bonding within the receptor pocket. Inversion of stereochemistry at C15 (15S to 15R) drastically reduces affinity.
- C-16/C-17 Modifications:
 - Native: n-pentyl chain is susceptible to rapid metabolic degradation.
 - Methylation (Iloprost): Introduction of a methyl group at C16 creates steric hindrance, blocking 15-hydroxy prostaglandin dehydrogenase (15-PGDH) and increasing half-life.

- Cycloalkyl/Aryl extension: Bulky groups (e.g., cyclohexyl in Clinprost or benzindene ring integration in Treprostini) enhance hydrophobic interaction and prevent metabolic attack.

The -Side Chain (Alpha Chain)

- Carboxyl Group (C1): Essential for ionic interaction with a conserved Arginine residue (Arg279) in the IP receptor transmembrane domain.
- Chain Length: The standard 4-carbon chain (from the ring to carboxyl) is optimal. Shortening or lengthening disrupts the alignment of the C1-carboxyl with the Arg279 anchor.

Visualization: Carbaprostacyclin SAR Map

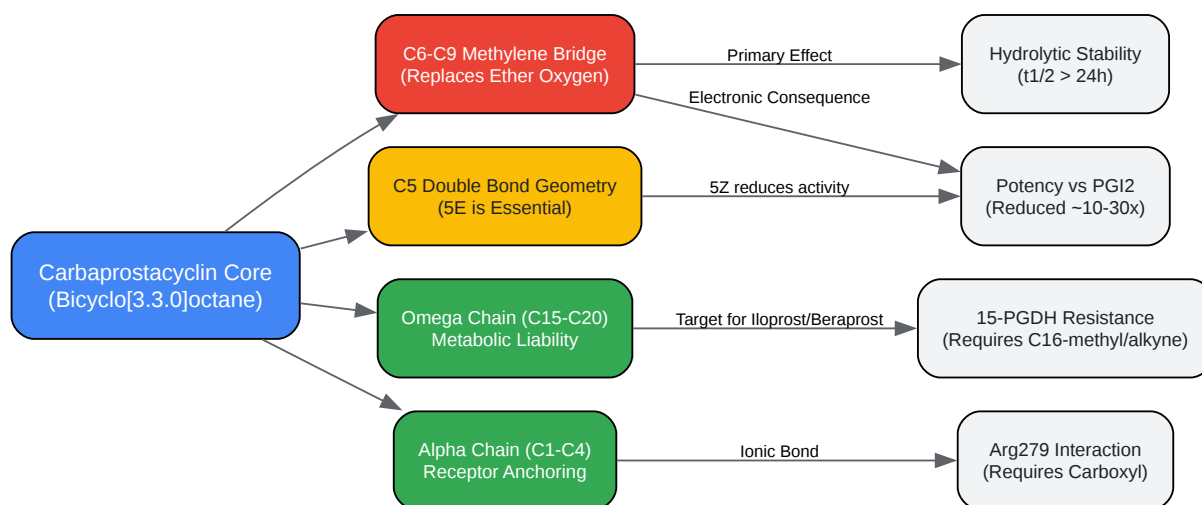

[Click to download full resolution via product page](#)

Figure 1: Structural dissection of Carbaprostacyclin highlighting regions critical for stability, potency, and receptor binding.

Pharmacology & Signaling Pathways[3][4]

Carbaprostacyclin analogs exert their effects primarily through the IP receptor, a G-protein coupled receptor (GPCR).

Signaling Cascade

- Ligand Binding: Carbacyclin binds to the IP receptor on the cell surface.
- G-Protein Activation: The receptor undergoes a conformational change, activating the G alpha subunit.
- Effector Modulation: G stimulates Adenylyl Cyclase (AC).
- Second Messenger: Intracellular cAMP levels rise.[3]
- Kinase Activation: cAMP activates Protein Kinase A (PKA).[3]
- Physiological Output:
 - Platelets: Phosphorylation of VASP (Vasodilator-stimulated phosphoprotein)
Inhibition of fibrinogen binding
Anti-aggregation.
 - Smooth Muscle:[1][2] Phosphorylation of Myosin Light Chain Kinase (MLCK)
Reduced Calcium sensitivity
Vasodilation.

Cross-Talk and Selectivity

High concentrations of carbacyclin analogs can exhibit "spillover" binding:

- EP1 Receptors: Iloprost shows significant affinity, potentially causing contraction in some tissues (unwanted side effect).
- PPAR

/

: Carbacyclins can act as ligands for nuclear Peroxisome Proliferator-Activated Receptors, contributing to long-term anti-proliferative effects in pulmonary hypertension.

Visualization: IP Receptor Signaling Pathway

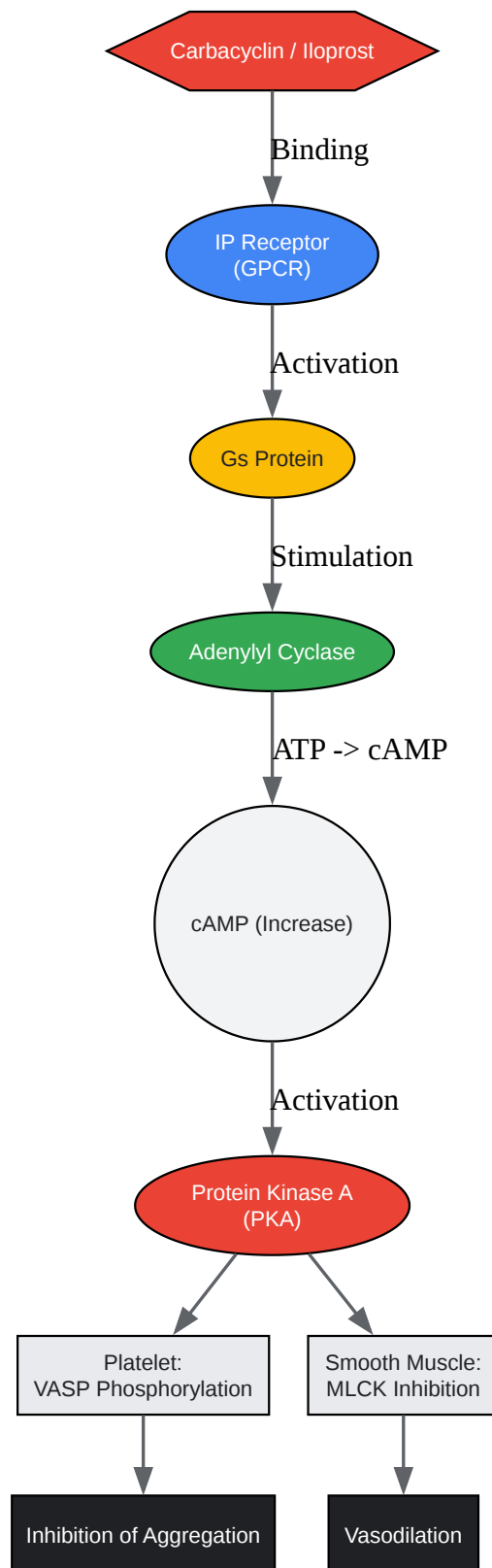

[Click to download full resolution via product page](#)

Figure 2: The canonical Gs-coupled signaling pathway activated by Carbaprostacyclin analogs.
[4]

Experimental Protocols

To validate SAR hypotheses, two primary assays are required: Receptor Binding (Affinity) and Platelet Aggregation (Efficacy).

Protocol A: IP Receptor Radioligand Binding Assay

Objective: Determine the affinity (

) of carbacyclin analogs for the human IP receptor.

Materials:

- HEK293 cells stably expressing human IP receptor.[5]
- Radioligand:
 - Iloprost (Specific Activity ~15-30 Ci/mmol).
- Cold Ligand: Unlabeled Carbacyclin analogs.
- Buffer: 50 mM Tris-HCl, 10 mM MgCl₂, pH 7.4.

Workflow:

- Membrane Preparation: Harvest HEK293 cells, homogenize in ice-cold buffer, and centrifuge (40,000 x g, 20 min). Resuspend pellet in buffer.
- Incubation: In 96-well plates, mix:
 - 50 μL Membrane suspension (20-50 μg protein).

- 50
L
-Iloprost (Final conc. ~1-2 nM).
- 50
L Competing Ligand (Concentration range
to
M).
- Equilibrium: Incubate at 25°C for 60 minutes.
- Termination: Rapid filtration through GF/B glass fiber filters using a cell harvester. Wash 3x with ice-cold buffer.
- Quantification: Add liquid scintillation cocktail to filters and count radioactivity (CPM).
- Analysis: Plot % Specific Binding vs. Log[Ligand]. Calculate IC
and derive
using the Cheng-Prusoff equation.

Protocol B: Light Transmission Aggregometry (LTA)

Objective: Assess the functional potency (IC

) of analogs in inhibiting platelet aggregation.

Workflow:

- Blood Collection: Draw human venous blood into 3.2% sodium citrate (9:1 v/v).
- PRP Preparation: Centrifuge at 200 x g for 15 min. Collect Platelet Rich Plasma (PRP).[6][7]
- Baseline: Prepare Platelet Poor Plasma (PPP) by centrifuging remaining blood at 2000 x g for 10 min (sets 100% transmission).

- Pre-incubation: Aliquot 450 L PRP into cuvettes. Add 5 L of Carbacyclin analog (various concentrations) or vehicle. Incubate 2 min at 37°C.
- Induction: Add agonist (e.g., ADP 5-10 M or Collagen 2 g/mL).
- Measurement: Monitor light transmission for 5-7 minutes under stirring (1000 rpm).
- Calculation:

Comparative Data Summary

The following table summarizes the SAR trends derived from binding and functional assays.

Compound	Structure Note	IP Receptor Affinity (, nM)	Platelet Inhibition (IC , nM)	Stability (pH 7.4)
PGI	Enol-ether (Native)	~ 1.0 - 3.0	2 - 5	Unstable (42s)
Carbacyclin (5E)	Methylene bridge	~ 30 - 100	15 - 50	Stable
Carbacyclin (5Z)	Isomer	> 1000	Partial Agonist	Stable
Iloprost	16-methyl + alkyne	~ 4.0	5 - 10	Stable
Treprostinil	Benzindene ring	~ 30	15 - 20	Stable (s.c. delivery)

Note: Values are approximate aggregates from multiple studies (Whittle et al., Schror et al.) intended for relative comparison.

References

- Whittle, B. J., et al. (1985). "Platelet actions of stable carbocyclic analogues of prostacyclin." *Circulation*.
- Corsini, A., et al. (1987). "(5Z)-carbacyclin discriminates between prostacyclin-receptors coupled to adenylate cyclase in vascular smooth muscle and platelets." [1] *British Journal of Pharmacology*.
- Jones, R. L., et al. (2024). "Binding and activity of the prostacyclin receptor (IP) agonists, treprostinil and iloprost." [5] *Prostaglandins & Other Lipid Mediators*.
- BenchChem Protocols. (2025). "Platelet Aggregation Assay Using PAR-4 Agonist Peptide."
- Collaborative Drug Discovery. (2025). "SAR: Structure Activity Relationships."

Need Custom Synthesis?

BenchChem offers custom synthesis for rare earth carbides and specific isotopic labeling.

Email: info@benchchem.com or [Request Quote Online](#).

Sources

- 1. (5Z)-carbacyclin discriminates between prostacyclin-receptors coupled to adenylate cyclase in vascular smooth muscle and platelets - PMC [[pmc.ncbi.nlm.nih.gov](https://pubmed.ncbi.nlm.nih.gov/)]
- 2. (5Z)-carbacyclin displays agonist-antagonist properties on prostacyclin-receptors in platelets and vascular myocytes - PubMed [pubmed.ncbi.nlm.nih.gov]
- 3. Prostacyclin - Wikipedia [en.wikipedia.org]
- 4. Prostacyclin receptor - Wikipedia [en.wikipedia.org]
- 5. [researchgate.net](https://www.researchgate.net/) [[researchgate.net](https://www.researchgate.net/)]
- 6. pdf.benchchem.com [pdf.benchchem.com]
- 7. Platelet aggregometry assay for evaluating the effects of platelet agonists and antiplatelet compounds on platelet function in vitro - PMC [[pmc.ncbi.nlm.nih.gov](https://pubmed.ncbi.nlm.nih.gov/)]
- To cite this document: BenchChem. [Carbaprostacyclin Structure-Activity Relationship (SAR) Analysis: A Technical Guide]. BenchChem, [2026]. [Online PDF]. Available at:

[<https://www.benchchem.com/product/b1252311/docs#carbaprostacyclin-structure-activity-relationship-sar-analysis-a-technical-guide>]

Disclaimer & Data Validity:

The information provided in this document is for Research Use Only (RUO) and is strictly not intended for diagnostic or therapeutic procedures. While BenchChem strives to provide accurate protocols, we make no warranties, express or implied, regarding the fitness of this product for every specific experimental setup.

Technical Support: The protocols provided are for reference purposes. Unsure if this reagent suits your experiment?

Need Industrial/Bulk Grade? [Request Custom Synthesis Quote](#)

BenchChem

Our mission is to be the trusted global source of essential and advanced chemicals, empowering scientists and researchers to drive progress in science and industry.

Contact

Address: 3281 E Guasti Rd
Ontario, CA 91761, United States
Phone: (601) 213-4426
Email: info@benchchem.com

[Contact our Ph.D. Support Team for a compatibility check](#)