

Chemoselectivity Support Center: Nitro Reduction in Halogenated Arenes

Author: BenchChem Technical Support Team. **Date:** April 2026

Compound of Interest

Compound Name: (2E)-3-(4-Bromo-2-nitrophenyl)prop-2-enoic acid

Cat. No.: B12514136

[Get Quote](#)

Status: Operational Ticket: #NR-Br-001 Subject: Minimizing Debromination during Nitro Reduction Assigned Specialist: Senior Application Scientist

Triage: The Chemoselectivity Paradox

Welcome to the technical support center. You are likely here because you are facing the classic "Chemoselectivity Paradox": You need to reduce a nitro group (

) to an amine (

), but your molecule contains a bromine (

) atom.

The Problem: The Carbon-Bromine (C-Br) bond is susceptible to cleavage (hydrodehalogenation) under the same reducing conditions used for nitro groups.^[1]

- Bond Dissociation Energy (Approx):

(~81 kcal/mol) vs

(~72 kcal/mol for the first reduction step).

- The Risk: Standard Palladium-catalyzed hydrogenation (, Pd/C) is notorious for rapid oxidative addition into the C-Br bond, leading to the des-bromo impurity (debromination).

Use the decision matrix below to select the correct protocol for your specific constraints.

Method Selection Decision Tree

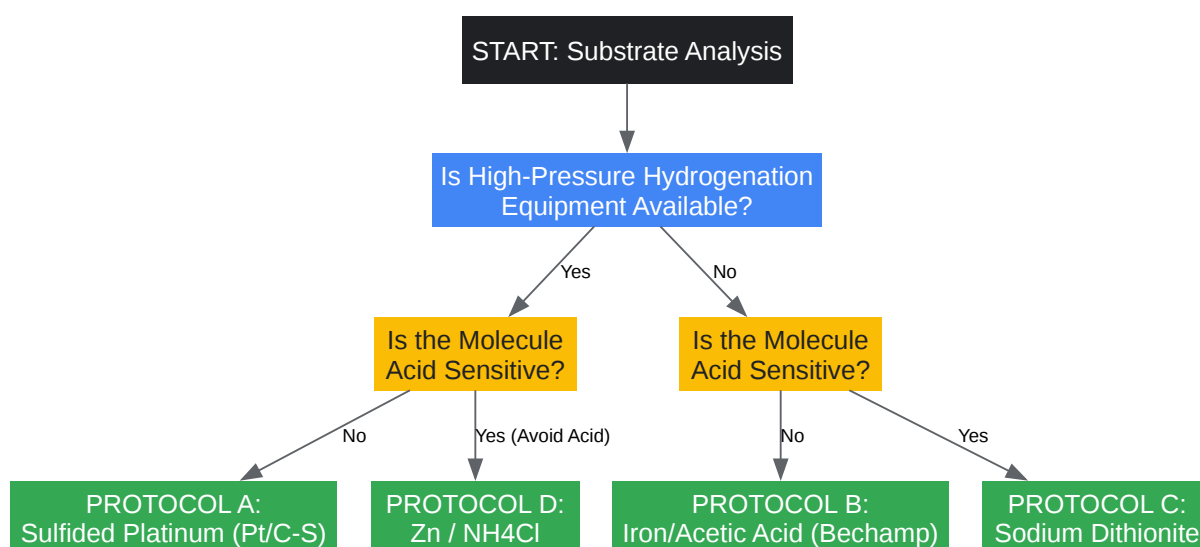

[Click to download full resolution via product page](#)

Figure 1: Strategic selection of reduction methodology based on equipment availability and substrate stability.

Experimental Protocols

Protocol A: Catalytic Hydrogenation (The Industrial Standard)

Best for: Scalable reactions, non-acid-sensitive substrates. The Fix: Switch from Palladium (Pd) to Sulfided Platinum (Pt/C-S).

Why it works: Unmodified Pd/C is highly active and readily inserts into C-Br bonds. Sulfided Platinum catalysts are "poisoned." The sulfur modifies the electronic properties of the metal surface, effectively shutting down the highly active sites required for C-Br hydrogenolysis while retaining sufficient activity to reduce the nitro group.

Step-by-Step Workflow:

- Preparation: Dissolve substrate (1.0 equiv) in THF or EtOAc. Avoid MeOH if possible, as protic solvents can sometimes accelerate debromination with certain catalysts.
- Catalyst Charge: Add 5% Pt/C (sulfided). A typical loading is 1-5 wt% relative to the substrate.
 - Critical Note: Do not use standard Pt/C; ensure it is the sulfided variant (often labeled "sulfided" or "poisoned").
- Hydrogenation:
 - Purge vessel 3x with Nitrogen ().
 - Purge vessel 3x with Hydrogen ().
 - Pressurize to 5–10 bar (approx. 70–145 psi).
 - Stir at Room Temperature. Heating increases the risk of debromination.
- Monitoring: Monitor via HPLC. Look for the hydroxylamine intermediate (). The reaction is complete only when this intermediate disappears.
- Workup: Filter through a Celite pad to remove the catalyst.^{[2][3]} Rinse with solvent.^[4] Concentrate filtrate.^[2]

Protocol B: Dissolving Metal Reduction (The Lab Workhorse)

Best for: Bench-scale, no hydrogenation equipment, robust substrates. The Fix: Iron powder in Acetic Acid.

Why it works: Iron has a lower reduction potential than the C-Br bond cleavage energy in these conditions. It operates via a single-electron transfer (SET) mechanism that is highly specific to the nitro group.

Step-by-Step Workflow:

- Charge: In a round-bottom flask, dissolve substrate (1.0 equiv) in Glacial Acetic Acid (AcOH) and Ethanol (1:1 ratio).
 - Concentration: ~0.2 M.
- Activation: Add Iron powder (Fe, 3.0–5.0 equiv).
 - Tip: Use "Reduced Iron Powder" (fine mesh) for better kinetics.
- Reaction: Heat to 60–70°C.
 - Caution: Exothermic induction period. Do not overheat immediately.
- Monitoring: TLC/LCMS will show conversion to aniline.
- Workup (The "Fe" Challenge):
 - Iron reactions often create emulsions.
 - Trick: Dilute with EtOAc, then filter through a Celite pad while the mixture is still warm.
 - Wash the filtrate with saturated

to neutralize the acid.

Protocol C: Sodium Dithionite (The Gentle Approach)

Best for: Acid-sensitive molecules, small scale. The Fix: Sodium Dithionite ([5])

Why it works: Dithionite works in neutral or basic media. It avoids the harsh acidic conditions of Fe/AcOH and the metal insertion risks of hydrogenation.

Step-by-Step Workflow:

- Solvent System: Dissolve substrate in THF/Water (1:1) or Dioxane/Water.
- Reagent: Add Sodium Dithionite (3.0–5.0 equiv).
 - Optional: Add a phase transfer catalyst (e.g., Viologen) if reaction is sluggish, though often not necessary for simple nitroarenes.
- Reaction: Stir at Room Temperature to 50°C.
- Buffering (Critical): The reaction generates bisulfite, which lowers pH. If your molecule is extremely acid-sensitive, add solid (2.0 equiv) to buffer the solution.
- Workup: Extract with EtOAc. The aqueous layer contains inorganic salts and can be discarded.

Comparative Data Analysis

Feature	Pd/C ()	Pt/C-S ()	Fe / AcOH	Na-Dithionite
Nitro Reduction	Excellent	Good	Excellent	Moderate
C-Br Stability	Poor (High Risk)	High	Very High	Very High
Reaction pH	Neutral	Neutral	Acidic	Neutral/Basic
Scalability	High	High	Moderate	Low/Moderate
Cost	High (Pd)	High (Pt)	Low	Low

Troubleshooting & FAQs

Symptom: "I am seeing 5-10% des-bromo impurity even with Pt/C-S."

Diagnosis: Your reaction temperature is likely too high, or the reaction ran too long. Corrective Action:

- Lower Temperature: Run at 10°C or 0°C. Selectivity is kinetically controlled; debromination has a higher activation energy than nitro reduction.
- Stop Early: Nitro reduction proceeds
 . Debromination usually competes at the

stage. Stop the reaction exactly when the starting material is consumed, even if trace hydroxylamine remains (which can be disproportionated later).

Symptom: "The Iron reaction turned into a solid sludge."

Diagnosis: Iron aggregates formed, or the concentration was too high. Corrective Action:

- Sonication: Sonicate the reaction mixture for 5 minutes to break up the iron surface oxides before heating.
- Mechanic Stirring: Use an overhead stirrer rather than a magnetic bar, which can get stuck in the iron sludge.

Symptom: "I must use Pd/C because I don't have Pt."

Diagnosis: You are forced to use a non-selective catalyst. Corrective Action: You must "poison" the catalyst in situ.

- Add Diphenylsulfide: Add 0.1–0.5 equiv of diphenylsulfide or thiophene to the reaction mixture. This mimics the commercial sulfided catalysts.
- Use Transfer Hydrogenation: Instead of

gas, use Hydrazine Hydrate in THF/MeOH at room temperature. This is often more selective than

gas.[3]

Mechanistic Visualization

The following diagram illustrates why Sulfided Platinum preserves the Bromine atom compared to standard Palladium.

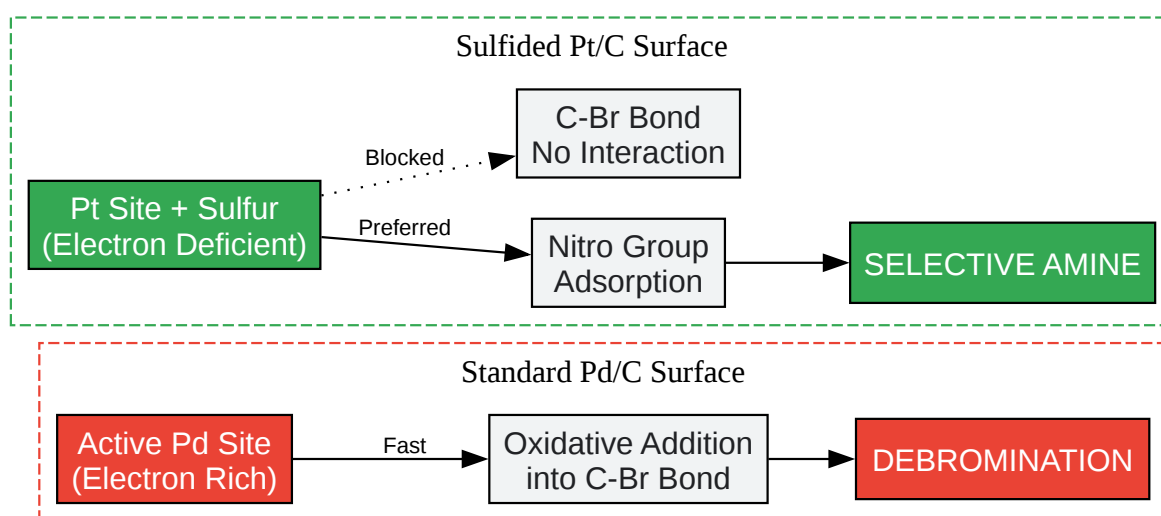

[Click to download full resolution via product page](#)

Figure 2: Mechanistic comparison of Pd vs. Pt-S surfaces. Sulfur modifies the catalyst geometry and electronics, preventing the C-Br bond from approaching the active site for cleavage.

References

- Blaser, H. U., et al. (2003). "Selective Hydrogenation for Fine Chemicals: Recent Trends and New Developments." *Advanced Synthesis & Catalysis*.
- Baumeister, P., Blaser, H. U., & Studer, M. (1997).[6] "Strong reduction of hydroxylamine accumulation in the catalytic hydrogenation of nitroarenes by vanadium promoters."

Catalysis Letters.

- Li, F., Frett, B., & Li, H. (2014).[7] "Selective Reduction of Halogenated Nitroarenes with Hydrazine Hydrate in the Presence of Pd/C." Synlett.
- BenchChem Technical Support. (2025). "Optimizing Sodium Dithionite Reductions." BenchChem.[1][5]
- Organic Chemistry Portal. (n.d.). "Reduction of Nitro Compounds."

Need Custom Synthesis?

BenchChem offers custom synthesis for rare earth carbides and specific isotopic labeling.

Email: info@benchchem.com or [Request Quote Online](#).

Sources

- 1. [benchchem.com](https://www.benchchem.com) [[benchchem.com](https://www.benchchem.com)]
- 2. pdf.benchchem.com [pdf.benchchem.com]
- 3. pdf.benchchem.com [pdf.benchchem.com]
- 4. chemistry.stackexchange.com [chemistry.stackexchange.com]
- 5. pdf.benchchem.com [pdf.benchchem.com]
- 6. [semanticscholar.org](https://www.semanticscholar.org) [[semanticscholar.org](https://www.semanticscholar.org)]
- 7. Selective Reduction of Halogenated Nitroarenes with Hydrazine Hydrate in the Presence of Pd/C [[organic-chemistry.org](https://www.organic-chemistry.org)]
- To cite this document: BenchChem. [Chemoselectivity Support Center: Nitro Reduction in Halogenated Arenes]. BenchChem, [2026]. [Online PDF]. Available at: [<https://www.benchchem.com/product/b12514136/docs#chemoselectivity-support-center-nitro-reduction-in-halogenated-arenes>]

Disclaimer & Data Validity:

The information provided in this document is for Research Use Only (RUO) and is strictly not intended for diagnostic or therapeutic procedures. While BenchChem strives to provide

accurate protocols, we make no warranties, express or implied, regarding the fitness of this product for every specific experimental setup.

Technical Support: The protocols provided are for reference purposes. Unsure if this reagent suits your experiment?

Need Industrial/Bulk Grade? [Request Custom Synthesis Quote](#)

BenchChem

Our mission is to be the trusted global source of essential and advanced chemicals, empowering scientists and researchers to drive progress in science and industry.

Contact

Address: 3281 E Guasti Rd

Ontario, CA 91761, United States

Phone: (601) 213-4426

Email: info@benchchem.com

[Contact our Ph.D. Support Team for a compatibility check](#)